

UNIVERSAL
LIBRARY



129 073

UNIVERSAL
LIBRARY

E. KENNETH BARRIE

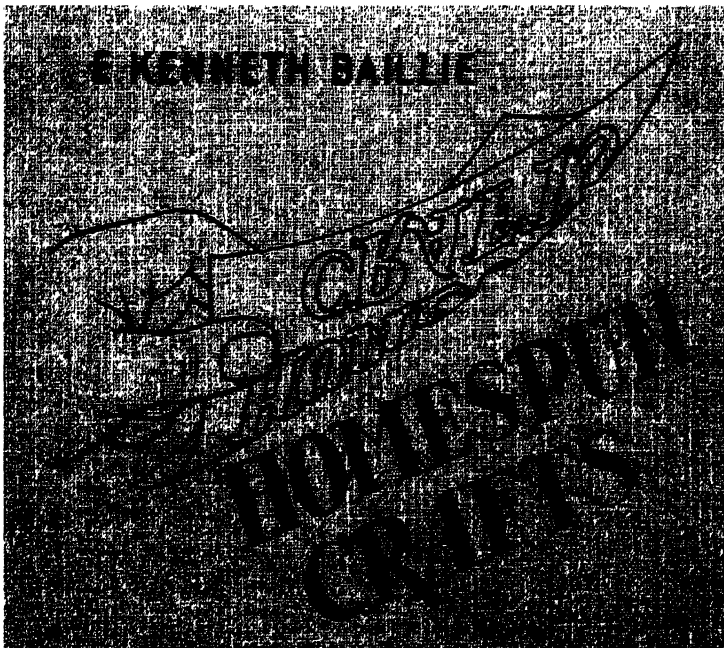

HOMESPUN CRAFTS



HOMESPUN CRAFTS

BY

E. KENNETH BAILLIE

DIRECTOR OF ART

NORTHERN STATE TEACHERS COLLEGE

ABERDEEN, SOUTH DAKOTA

THE BRUCE PUBLISHING COMPANY
MILWAUKEE

FOR GLADYS AND BRUCE

Copyright, 1952, E. Kenneth Baillie
Made in the United States of America

FOREWORD

Here is a book for you — hobbyists, teachers, occupational therapists, youth leaders, Boy and Girl Scouts, and home demonstration groups.

Throughout his years at Northern State Teachers College at Aberdeen, South Dakota, Mr. Baillie has given the art department there a special distinction through his careful and inspired development of countless valuable and often overlooked materials. He has started many young teachers, artists, and craftsmen on successful careers in the schools and in commercial art and craft fields. By him they have been taught to use the materials about them sincerely, sympathetically, and creatively with varied and fascinating results.

If there were any reason for my thoughts or my name appearing on this page, it would not be with the intent to add anything to an already complete, rich, and useful book. There are, however, three simple reasons. I am a native of South Dakota, where this publication had its origin. I have been “raised” on homespun materials and feel their worth, and I have known E. Kenneth Baillie for the many years through which he has worked, played, dreamed, and lived his “Homespun.” So it is with true and sincere appreciation that I add a word of introduction to recommend a helpful and inspirational book.

In these pages the potential of each native material — wood, metal, leather, glass, felt, and other “native” craft media — has been explored, mapped, and charted. Sources for these materials are treated exhaustively.

Art is an elusive element which has been defined in many terms. Here we have it defined and implemented in the answers to the questions, “What to do?” “What to do with it?” and “How to do it?” This book answers these questions and all the answers are clear, concise, simple, and direct. The artist, teacher, craftsman, and youth leader will discover here a wealth of material which he will not only recognize for its outstanding worth but will put to immediate and concrete use.

ROBERT SILL

PREFACE

The material in this book was compiled by the author to provide interesting and useful craft projects for students, teachers, youth leaders, occupational therapists, hobbyists, and various social organizations which engage in craftwork as part of their activities. These organizations, incidentally, might not only find herein recreational activities but also "fund raising" sources through the sale of homespun articles.

The projects in HOMESPUN CRAFTS were developed by the author and completed as class assignments under his supervision at Northern State Teachers College, Aberdeen, South Dakota. The material had its beginning during the depression years, when students and instructor alike cast about for "native" materials with an eye for usable media in the school, the home, or in the church, with which to carry on their art and craft activities. This became increasingly necessary because of a lack of funds for professional art materials. During World War II, homespun was continued in the craft classes at Northern, not because of a lack of funds, which then were ample, but because of the scarcity of standard art materials, a situation which at the present writing is beginning to recur on a small scale.

To complete most of the articles in this book the homespun way, used or discarded materials such as those described on pages 9 and 10 can be used. The source of supply of "native materials" is inexhaustible: it replenishes itself constantly. By "native" material is meant those craft materials which can be salvaged from used articles of clothing, household articles, etc., which have served their purpose and collect in attics, school storerooms, and similar places. Merchants will gladly donate last season's merchandise to schools and churches when advised as to how it will aid the users.

E. KENNETH BAILLIE

CONTENTS

Foreword	5
Preface	6
Native Materials	9

SECTION 1—LEATHER

Leather or Plastic Coin Purse	11
Boys' or Girls' Billfold	14
Snapshot Folder	16
Stationery Case and Writing Pad	18
Desk Set With Leather Corners	20
Metal Book Ends With Leather	22
Star Coin Purse or Rosary Case	24
Boys' and Girls' Leather Belts	26
Children's Bookmarks	28
"Shower" Baby Shoes	30

SECTION 2—WOOD

Decorative Carving Board	33
Lamp, Fruit Bowl, and Jewel Box	35
Metal Name Plate for Desk	38
Spool Toy for Baby	40
Salt and Pepper Shakers and Sportswear Buttons	42
Rustic Book Ends	45
Rustic Door Knocker	48
Rustic Whatnot	50
Rustic Birdhouse With Bath	52
Camp Comfort	54

SECTION 3—METAL

Christmas Tree Ornaments	57
Christmas Tree Angel	59
Holiday Candlesticks	62
Darning Kit for Traveling	64
Children's Toy Drum	66
Aluminum or Copper Bud Vase	68

Letter Holder	70
Ash Tray or Pin Tray	72
Napkin Ring or Bracelet	74
Bracelet, Money Clip, and Tie Clasp	76

SECTION 4 — FELT

Felt and Plastic Cosmetic Kit	80
Potted Cactus Pincushion for the Flower Stand	82
Felt Pumpkin Tea Cozy	85
Hot-Dish Holder or Table Pad	88
Felt Handbag	90
Felt and Fur Ear Muffs for Girls	93
Child's Swiss Bonnet	95
Pullman Slippers and Case	98
Felt and Yarn Toy Bunny or Beanbag	100
Needle Book and Thimble Hat	102

SECTION 5 — GLASS

Hang a Decorative Plate or Picture Without a Frame	106
Decorative Mirrors and Mirror Picture	109
Studio Bottle	111
How to Cut Glass Bottles	114
Hurricane Lamps and Lantern	116
Sandwich Tray	119
Mirror Place Cards	122
Indoor Garden Under Glass	124
Mirror or Plate Glass Centerpiece	127
Brighten the Kitchen With Glassware	130

SECTION 6 — VARI-CRAFT

Pot Holder and T Towel Rack	133
Necktie or Towel Rack	135
Lapel Pins and Earrings	138
Doll Hats	140
Life-of-the-Party Hats	143
Painted Stone Paperweight and Block Prints	145
A Record Craft	148
Handmade Christmas Cards	151
Fun With Easter Eggs	154
Lamp Shade and Cabin Curtains	156

NATIVE MATERIALS

Felt. Felt may be salvaged from women's and men's discarded felt hats, college pennants, the worn covering from a billiard table, etc. Most women's ready-to-wear shops and departments, or millinery stores will donate last season's hats to organizations such as those listed above, especially to Scout troops and Campfire Girls groups.

Tin. Vegetable and fruit cans give the craftsman an abundant source of tin in bright silver and gold of several tones. Tops and bottoms are salvaged, together with the remainder of the can which is cut at the seam and rolled flat with some instrument such as a rolling pin.

Wood. Scraps of some very beautiful woods can be found in the kindling pile. Orange crates and apple boxes have good wood. Flat disks of wood or short chunks from the larger branches of a dead or fallen tree serve as a basic material for many crafts.

Leather. Leather from soiled or torn leather jackets, women's discarded leather purses, men's worn billfolds, and kid gloves supply the leather craftsman with ample material. Many yards of leather lacing can be cut from a single glove and is strong as well as colorful.

Paper. Many types of paper are usable in craftwork. Save greeting cards of all types and the gold and silver metallic papers on greeting cards. Wallpaper and the decorative wrappings from Christmas packages are very helpful.

Glass. Ginger ale, wine and pop bottles, attractive and colored glass cologne containers, fruit juice and cider jugs are versatile bases for projects in glass. Glass from broken window panes is a valuable craft medium. Save the convex glass from oval picture frames and wall clocks. Small mirrors from any lady's purse or large unused mirrors can be fashioned into attractive items.

Paints. Many crafts require some type of finish. Hoard bits of household paint, lacquers, enamels, shellac, and varnish. These will be found stored in garages, barns, and the home. With a supply of nail polish, the above will suffice for this necessary craft medium.

Miscellaneous. As supplementary craft materials, collect bits of fancy wrapping cords and ribbons like those used to tie Christmas gifts. Also save all types, sizes, and colors of beads and other discarded or broken jewelry. Sequins from hats, scarves, and dresses are a very effective decorative material. Table salt or sugar, with nail polish will give a sparkling coat to wood or tin articles.

Cotton. Cotton is used to a great extent in stuffing and padding articles made of felt. It is suggested that padding from an upholstered chair or sofa be saved when furniture is to be recovered. Cotton batting left over from quilting and scraps of cotton from the medicine chest will come in handy.

Tools. In general, special tools are not required for the articles presented. The average run of tools found around the home and in the school will suffice. Assemble sandpaper, steel wool, hammers, pliers, screw drivers, and saws of all types. Gather brushes of all sizes; pocket knives; razor blades; office equipment such as a paper punch and scissors; and sewing equipment including needles, thimble, threads, and pinking shears. These will give the craftsman an abundant supply of tools with which to fashion artistic and useful objects with a professional touch.

Professional Helps. Art companies and art supplies for those who require certain materials and tools will be found in the back of the book.

Patterns. Patterns are shown in the illustrations for some of the craft problems. These patterns are not given in full size. Where patterns are required, it is suggested that they be redrawn. To make a pattern, rule a sheet of paper into one inch squares. On this squared sheet redraw the patterns to the required measurements.

SECTION 1 — LEATHER

LEATHER OR PLASTIC COIN PURSE

MATERIALS

Leathers: Soft-grained leathers, preferably calf, are excellent for tooling. Use larger pieces for the coin purse in Plate 1; smaller ones for lacing. Leather for lacing (Fig. 5).

Decorations: Metal nailheads from a formal gown can be used for decoration, if desired.

Linings: The coin purse may be lined with scrap silk or the thin kid with which some purses are lined.

Other Materials: Paper for patterns, glue or clear nail polish to secure the ends of the lacing, and wax or paste shoe polish to finish the leather.

TOOLS

Pencil and ruler for making patterns; razor blade for ripping apart the old purse; metal-edged ruler and cutting board for cutting leather; leather tool or a steel knitting needle or large, smooth-pointed nail for modeling leather; and leather punch or paper punch for making lacing holes.

PROCEDURE

1. With a razor blade, rip the leather purse at the seams. Clean the leather with cleaning fluid or soap in cool water. Soak wrinkled leather in water; then with pins, stretch it on a board until dry. Renew the leather finish with paste floor wax or paste shoe polish.
2. Draw the half-pattern (Fig. 2) on a folded piece of paper and cut it out. When unfolded it will be a complete pattern (Fig. 4). Make a pattern of the slot (Fig. 3).
3. Draw the outlines of the patterns on the leather with a piece of pointed chalk or soap shaved to a sharp edge.
4. Using a razor blade and a metal-edged ruler, cut the leather (Figs.

- 1 and 3). Dampen the leather and fold it (Fig. 2). Press it for a half hour under a book.
5. Use commercial lacing or make the lacing as shown in Figure 5. Attach the nailheads for the design, if desired, before lacing. Plastic lacing can be used if desired.
 6. For tooling, soak the leather thoroughly in cool water and remove the excess moisture by patting with a soft cloth. Trace the designs on the wet leather with a leather modeling tool or a knitting needle. Then, remove the paper pattern and work the design deep into the leather and let it dry.
 7. Cut the four slits (Fig. 1) for the slot (Fig. 3). Insert the slot (Fig. 1).
 8. Punch holes for the lacing as illustrated (Fig. 2). Lace the purse with an overcast or blanket stitch. For the overcast stitch (Plate 1, Fig. 1), the length of the lacing must be three times the distance around the article; for the blanket stitch (Plate 6, Fig. 5), the lacing must be five times this distance. Dip the sewing end of the lacing in clear nail polish and let it dry. Start lacing at the top left corner and end at the top right corner. Leave about $1\frac{1}{2}$ in. of lacing at both ends. Push the ends back into the fold and secure them with glue.

LEATHER OR PLASTIC COIN PURSE

FROM
LADIES' DISCARDED PURSES.



Fig. 5.

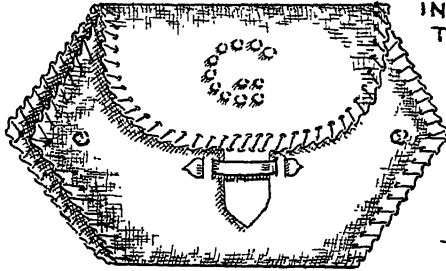

Fig. 1.

TO MAKE LACING HOLES MATCH ~ FOLD EDGES (A & B) TOGETHER & PUNCH.

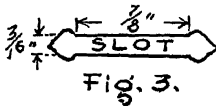

Fig. 3.

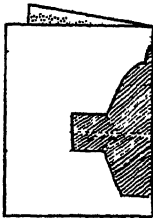
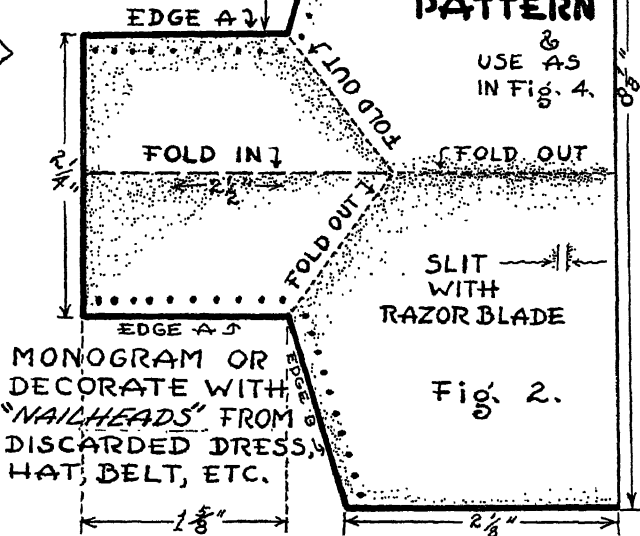

Fig. 4.

DIP TIP OF LACING IN NAIL POLISH TO STIFFEN.



MAKE A
HALF
PATTERN

USE AS
IN Fig. 4.

SLIT WITH
RAZOR BLADE

Fig. 2.

MONOGRAM OR
DECORATE WITH
"NAILHEADS" FROM
DISCARDED DRESS,
HAT, BELT, ETC.

Plate 1

BOYS' OR GIRLS' BILLFOLD

MATERIALS

Leather: Leather from ladies' discarded envelope-type purses, heavier leathers for the billfolds in Plate 2 and lightweight kid for lacing.

Other Materials: Paper for patterns, glue or clear nail polish, and wax for the leather.

TOOLS

Pencil and ruler for making patterns; razor blade, metal-edged ruler, and cutting board for cutting leather; and leather or paper punch.

PROCEDURE

1. Rip apart the purses at the seams with a razor blade. Prepare the leather as in Section 1, "Leather or Plastic Coin Purse," step 1.
2. Figure 1 is a half pattern. It represents half the length of the billfold. Use this same pattern for the lining ($3\frac{1}{8}$ in. wide), the divider ($3\frac{1}{4}$ in. wide), and the cover ($3\frac{3}{4}$ in. wide). Figure 2 shows the pocket pattern—make two. Figure 3 illustrates the arrangement of all pieces. On separate pieces of paper, draw all three half patterns. Fold each pattern at the dotted half line and cut. Unfolded, each pattern will be full size. Note the hem at the top of the cover piece (Fig. 1). Fold this hem on the dotted line and round both ends with a razor blade as illustrated.
3. Draw the outline of each pattern on a piece of leather of corresponding size.
4. Cut the leather to size with a metal-edged ruler and razor blade. Cut around a coin for rounded corners. One pocket should be cut with a reversed pattern. Also cut out the opening as shown in the lining (Fig. 1).
5. Place the five pieces of leather together in their proper positions, with the cover in reverse to the other pieces. Fold back the hem of the cover. Fasten the pieces together with paper clips and then punch for lacing.

BOYS' OR GIRLS' BILLFOLD =

made from

LADIES' DISCARDED LEATHER
OR PLASTIC PURSES.

MAKE ALL PATTERNS—
PLACE ON LEATHER AND CUT
ENTIRELY WITH RAZOR BLADE
AND METAL-
EDGED RULER.

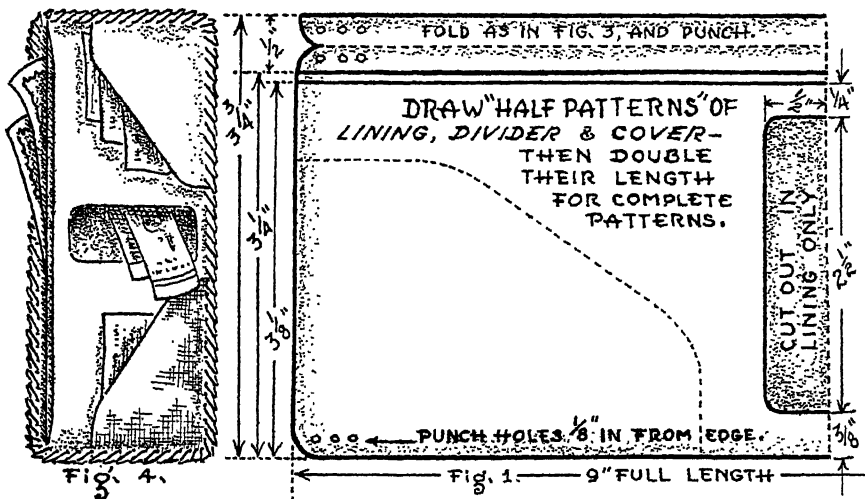
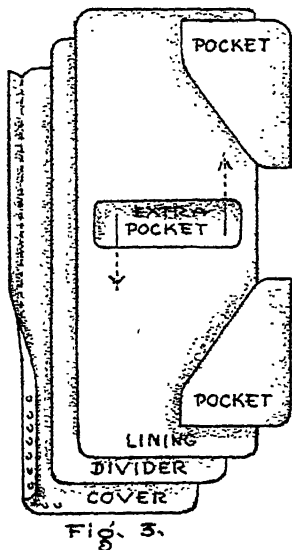
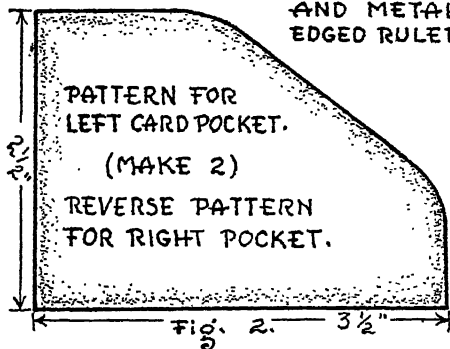

Plate 2

6. Lace the article, starting in the lower, left-hand corner (see Section 1, "Leather or Plastic Coin Purse," steps 5 and 8).
7. Fold and press the billfold under a weight for several hours.

SNAPSHOT FOLDER

MATERIALS

Leather: A large envelope-type of lady's purse will furnish enough leather for the folder in Plate 3. A small, thin piece of leather lines the hinge of the folder. Make leather lacing (Plate 1, Fig. 5).

Silk Lining: Purse linings may be used for the window lining.

Clear Celluloid or Plastic: Clear celluloid from old billfolds or frost shields from car windows will make panes for the windows.

Other Materials: Paper for patterns, glue or clear nail polish, and wax for the leather.

TOOLS

Pencil, paper clips, razor blades to rip apart the discarded leather, metal-edged ruler and a board for cutting the leather, and leather or paper punch.

PROCEDURE

1. Rip apart the purse and prepare the leather (see page 11, step 1).
2. Make the patterns.
3. Lay two pieces of leather back to back. Draw the outline of the pattern on the top piece with chalk or pencil. The window mats may be made from separate pieces. Make the inserts from lighter weight leather. A larger folder may be desired. Always make the window slightly smaller than the picture it will frame. The mat should be the same width on all sides.
4. Place the mat piece and the cover pieces back to back, clip them together with paper clips, lay them on a smooth board, and cut with a razor blade and a metal-edged ruler. Use a small coin to shape rounded corners. Keep these pieces clipped together for punching. Cut the other pieces.
5. Cut lining in one or two pieces from scrap silk.
6. Place the insert between the cover and the mats and punch holes for lacing.
7. Lace the article (see page 12, steps 5 and 8).
8. Insert snapshots, fold the holder, and weight down.

SNAPSHOT FOLDER

made from

LADIES' DISCARDED LEATHER OR PLASTIC PURSES.

CUT 2 PIECES OF LEATHER OR PLASTIC, $8\frac{3}{8}$ " x $4\frac{7}{8}$ " FROM DISCARDED PURSE, & TRIM AS PER DIRECTIONS - LINE WITH SCRAP SILK. (USE LEATHER INSERT AT HINGE)

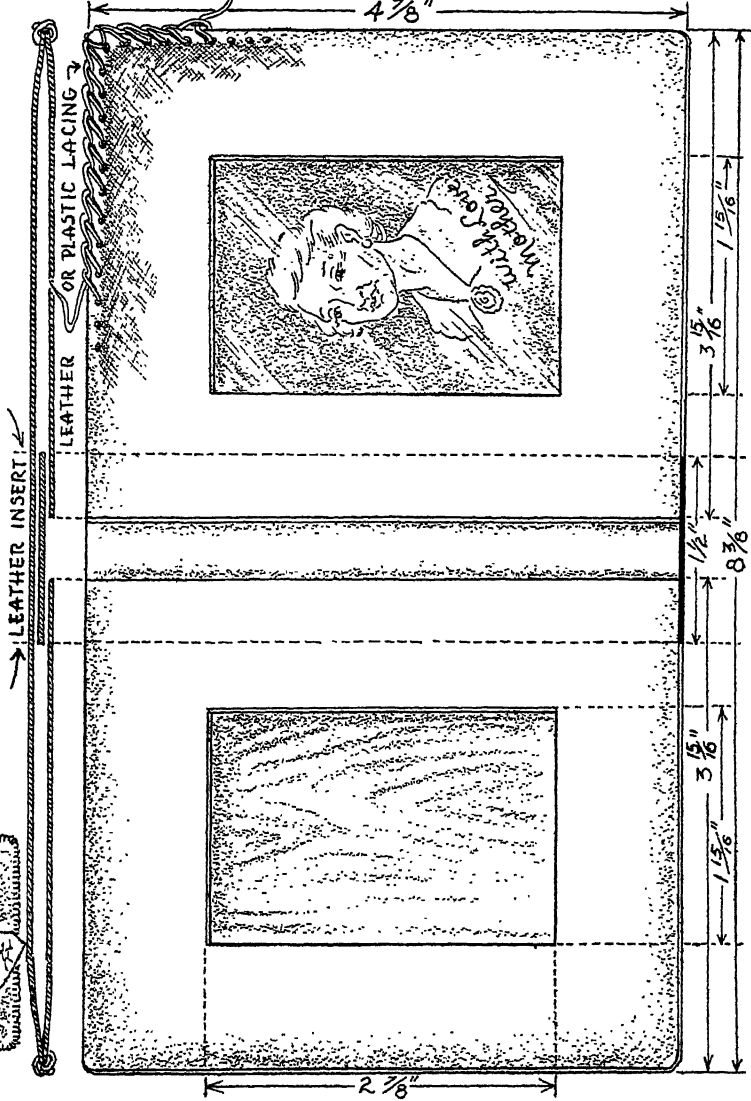
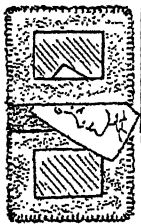

Plate 3

STATIONERY CASE AND WRITING PAD

MATERIALS

Leather: A discarded lady's heavy leather purse, large enough to make the cover (Plate 4, Fig. 3) in one or two pieces, the two corners (Fig. 4), and the pocket (Fig. 5). Leather lacing is required (Plate 1, Fig. 5).

Cardboard and Blotter: One piece each of cardboard and colored blotter, $10\frac{1}{4}$ by $7\frac{1}{2}$ in. (Figs. 6 and 7). The cardboard in Figures 6 and 7 should be quite stiff since it is used as a backing for the blotter, which in turn is the writing surface. Large colored blotters may be purchased at a school supply store or a print shop. Unfolded stationery is indicated for this article. Note that a book of stamps and a pen may be kept conveniently inside the case.

Other Materials: Paper for patterns, glue or clear nail polish, and wax for the leather.

TOOLS

Pencil for making patterns and paper clips for holding leather while lacing, steel-edged ruler, razor blades, wood or glass cutting board, and a leather or paper punch.

PROCEDURE

1. Rip the purse with a razor blade. Prepare the leather as in Section 1, "Leather or Plastic Coin Purse," step 1.
2. On a large sheet of wrapping paper, place two sheets of stationery side by side, 1 in. apart (Fig. 1). Using a pencil and ruler, draw a line $\frac{1}{2}$ in. from the edge of the stationery, enclosing the two pieces in one large pattern. If the leather is not large enough for the cover, use two pieces (Fig. 3). Figures 4 and 5 are patterns for corners and the pocket for the stationery.
3. Lay the paper patterns on the unglazed side of the leather and draw the outlines.
4. Lay the leather on a cutting board, and, using a steel-edged ruler and razor blade, cut the leather.

STATIONERY CASE & WRITING PAD

made from LADIES' DISCARDED LEATHER PURSES.



Fig. 2.

CARDBOARD, BLOTTERS, AND PLASTIC OR HANDMADE LEATHER LACING.

TOOLS: RULER WITH A STEEL EDGE, RAZOR BLADE, LEATHER OR PAPER PUNCH.

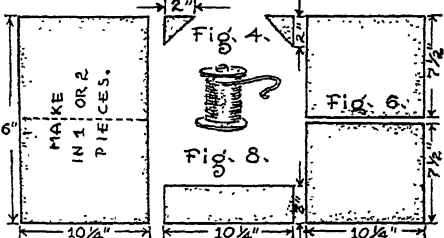

Fig. 3.

Fig. 5.

Fig. 7.

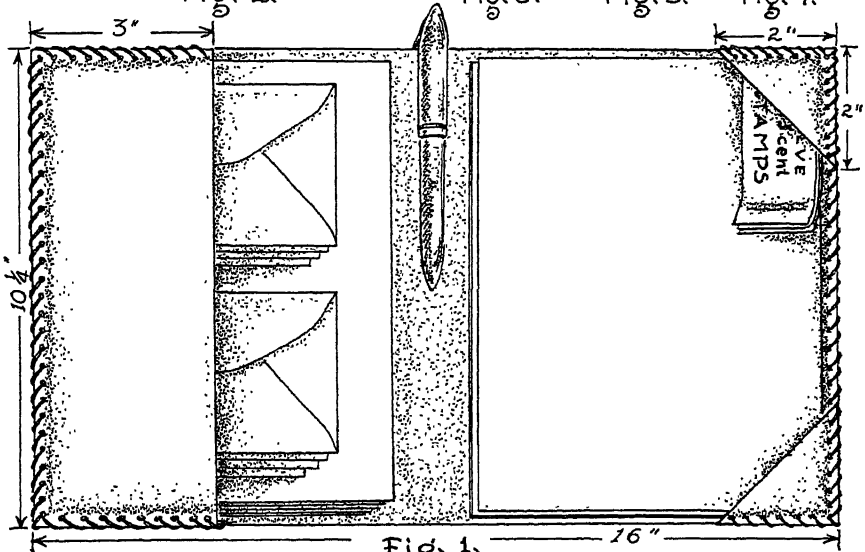

Fig. 1.

Plate 4

5. As in Figure 1, place the pieces of leather back to back, clip them together with paper clips, and punch holes for lacing.
6. Use any style of lacing (see Section 1, "Leather or Plastic Coin Purse," steps 5 and 8).

DESK SET WITH LEATHER CORNERS

MATERIALS

Leather: Leather from one or two lady's discarded purses to make the four corners and the scissor and knife sheath in Plate 5. Leather for lacing (Plate 1, Fig. 5).

Cardboard and Blotter: Use blotters about 18 by 24 in. for an office desk and about 11 by 15 in. for a desk top at home.

Wallpaper: Wallpaper of simple design for the backing of the desk pad or heavy decorative gift wrapping paper.

Other Materials: Paper for patterns, glue or clear nail polish, and wax for the leather.

TOOLS

Pencil for tracing patterns; metal-edged ruler, razor blades, and board for cutting leather; steel knitting needle or leather modeling tool for tooling the leather if desired; large sharp scissors; leather or paper punch; and carpenter's square if available.

PROCEDURE

Sheath

1. Rip the purses apart and prepare the leather (see page 11, step 1).
2. Lay the scissors and letter opener on a paper in the position shown in Figure 6 and trace loosely around them with pencil. Fold the drawing down the middle from end to end and cut out.
3. Unfold and lay the pattern on two thicknesses of leather (both finished surfaces up). Trace around the pattern with a pencil or crayon.
4. Pin the leather to a board and cut both thicknesses at the same time.
5. Clip the pieces of leather together and punch holes for lacing.
6. Lace the corners (see page 12, steps 5 and 8).

Blotter Corners

Figure 1 shows the finished blotter corner. Make four, using Figure 2 for a guide (see also Figures 4 and 5). The corners should be glued to the cardboard base as in Figure 3.

Figure 7 illustrates lightweight leather lined with lightweight card-

DESK SET *with* LEATHER CORNERS

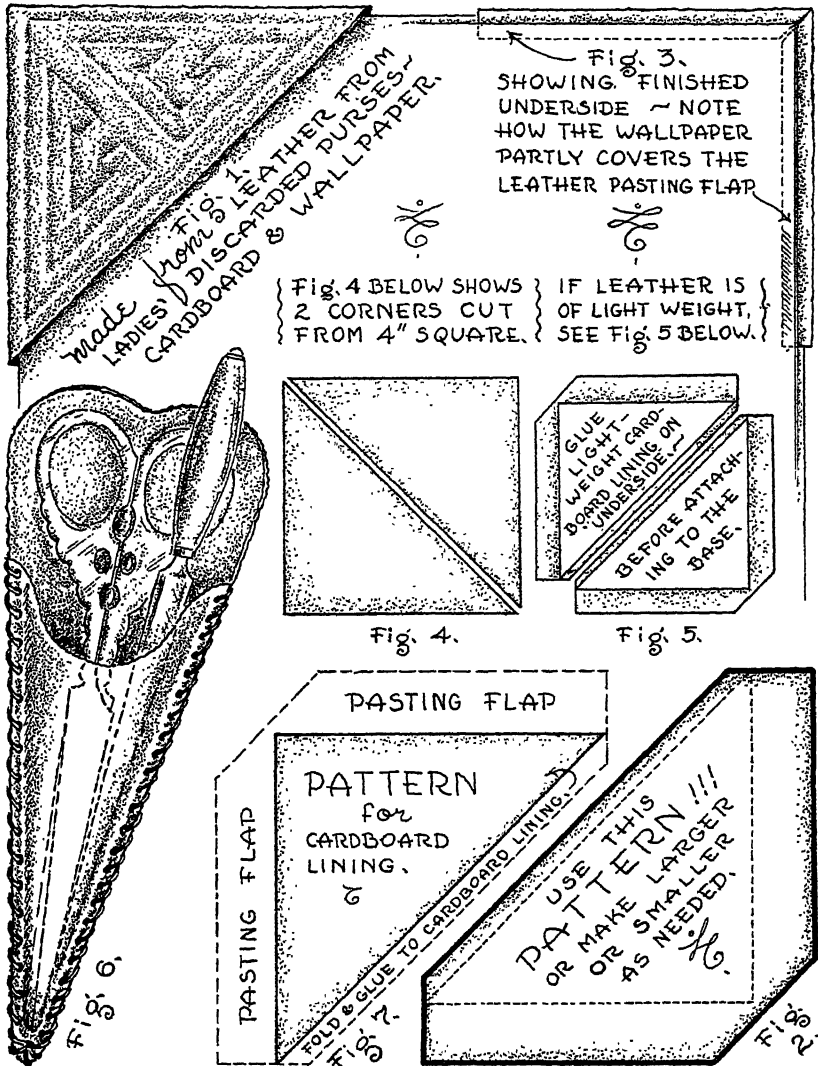

Plate 5

board and shows a pasting flap which is glued to the lining before the larger flaps are attached over the base.

Plastic or leatherette may be used instead of leather. It may be more practical in the lower grades.

METAL BOOK ENDS WITH LEATHER

MATERIALS

Metals: Scrap aluminum, flashing copper, or furnace metal for the book ends in Plate 6— if not available at home, a tinsmith's shop will have it.

Leather, Plastic, and Felt: Leathers from ladies' discarded purses. Felt or plastic may be used in place of leather. Felt also may be used for padding under the leather. Leather for lacing (Plate 1, Fig. 5).

Other Materials: Paper for patterns, clear nail polish or shellac, and wax for the leather.

TOOLS

Pencil for making patterns, metal-edged ruler and razor blade, tin snips and metal file, and paper punch or leather punch for the lacing holes.

PROCEDURE

Book Ends in Figure 3

1. Rip apart the purse with a razor blade. Prepare the leather as in Section 1, "Leather or Plastic Coin Purse," step 1.
2. Make the patterns.
3. Using tin snips and the metal pattern (Fig. 1), cut out two pieces of metal for the book ends. Smooth the edges of the metal with a file.
4. Place the leather pattern (Fig. 1), which is $\frac{1}{8}$ in. larger than the metal pattern all around, over the two reversed thicknesses of leather and draw around it with chalk.
5. Lay the two pieces of leather back to back on a board and cut them to size with a razor blade and metal ruler.
6. Holding the leather together with paper clips, punch holes $\frac{1}{8}$ in. from the edge for lacing (Fig. 6).
7. If desired, for a professional touch, cut felt the size of the metal and glue it to the outside surface of the metal before covering with leather (Fig. 6).
8. Lace the two cover pieces together back to back, beginning at one

METAL BOOK ENDS *with* LEATHER

made from
SCRAP ALUMINUM OR
COPPER FLASHING COVERED
WITH SCRAP LEATHER OR FELT.

TOOLS:

TIN SNIPS TO CUT METAL AND A
PENCIL, PAPER FOR PATTERNS,
RAZOR BLADE, STEEL EDGED RULER
TO CUT LEATHER & A LEATHER
PUNCH. LACE WITH LEATHER
OR PLASTIC LACING.



Fig. 5.



Fig. 6.

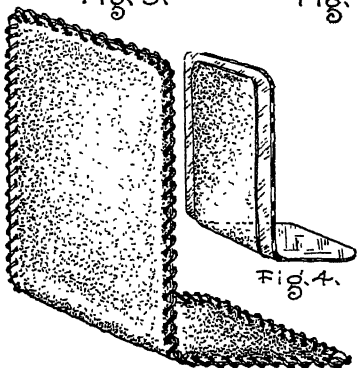

Fig. 3.

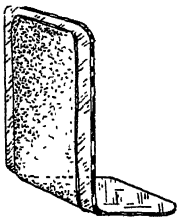

Fig. 4.

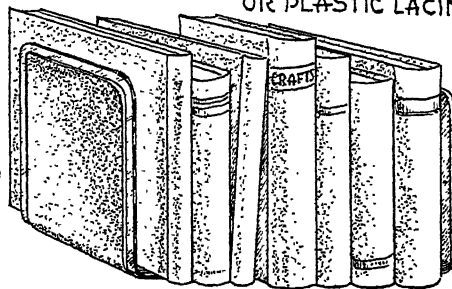

Fig. 2.

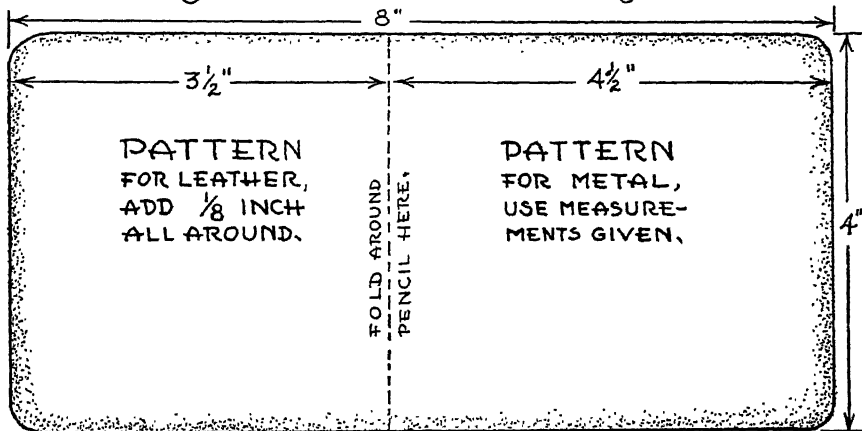

Fig. 1.

Plate 6

corner (see Section 1, "Leather or Plastic Coin Purse," steps 5 and 8). Insert the metal after three sides are laced. Complete the lacing, securing the ends through the beginning hole with clear nail polish. Figure 3 is the finished article. Figure 5 shows another style of lacing. After lacing, bend the book end over a chair rung (Fig. 3).

Book End in Figure 4

The book end in Figure 4 can be made of copper or aluminum. Finish the edges smoothly with a metal file and polish with steel wool, rubbing in one direction only. Use a fine-grained leather which is cut $\frac{1}{2}$ in. smaller than the metal. Attach the leather to the outside surface of the metal with rubber cement.

STAR COIN PURSE OR ROSARY CASE

MATERIALS

Leather: A lady's leather purse of calfskin or stiff leather, large enough to make the rosary case, and enough for one circle of the same leather, $2\frac{1}{2}$ in. in diameter (Plate 7, Fig. 2).

Glue: Rubber cement will hold the leather surfaces together for continued use.

Other Materials: Paper for patterns and wax for the leather.

TOOLS

Ruler, compass, and pencil for making patterns; razor blade and steel-edged ruler; paper or leather punch; cutting board; and a weight for pressing creases in the leather.

PROCEDURE

1. Rip apart the purse with a razor blade. Prepare the leather as in Section 1, "Leather or Plastic Coin Purse," step 1.
2. Make the patterns shown in Figures 1 and 2 including all dotted lines.
3. Lay the patterns on the underside of the leather and draw around the edges with chalk or colored crayon. Indicate the black dots on the leather. It is not necessary to trace the dotted lines.

STAR COIN PURSE OR ROSARY CASE

made from
LADIES' DISCARDED HEAVY-
LEATHER PURSES.



TOOLS:

A STEEL EDGED RULER—
RAZOR BLADES—A PAPER
OR LEATHER PUNCH—A
PAN OF COOL WATER—A
CUTTING BOARD AND
PRESSING WEIGHT.

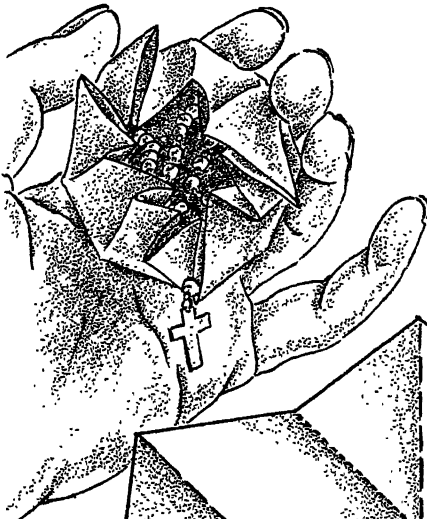

Fig. 3.

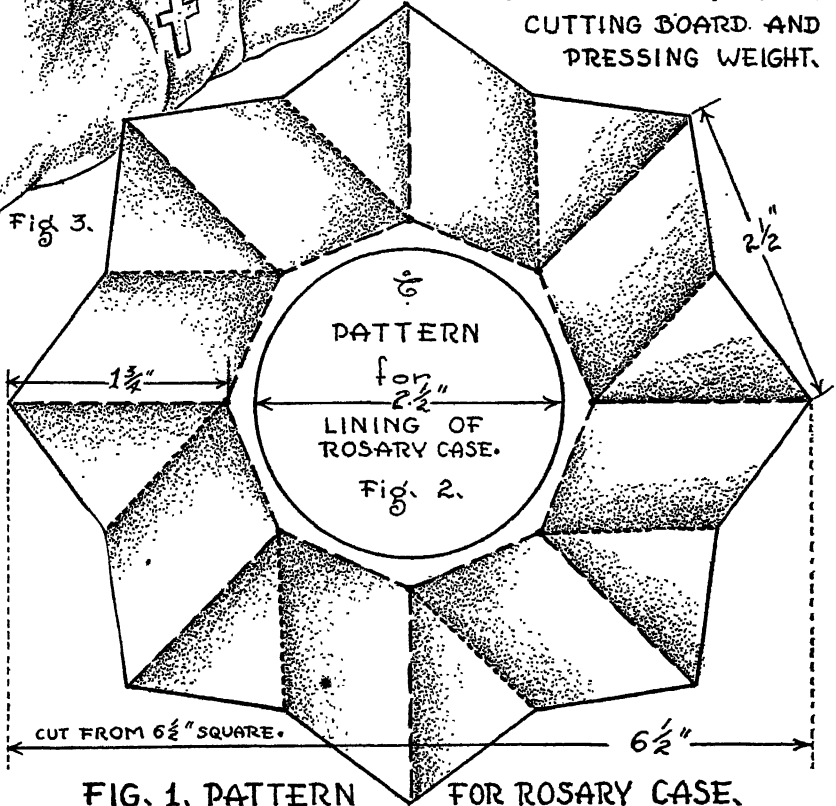

Plate 7

4. Using a metal-edged ruler, cut the leather on a smooth board (Fig. 1). Cut the piece in Figure 2 with a heavy, sharp shears.
5. When the leather for the part shown in Figure 1 has been cut, punch out the black dots with the smallest punch available.
6. Soak the leather in cool water and lay it flat on a board. Press out the excess water with the hand and crease as illustrated. Be sure to place the finished side of the leather up and crease out along the long dotted lines from hole to hole. Crease in along the short dotted lines (Fig. 1).
7. Having made the creases, while the leather is still wet, place it on a folded cloth, cover it with another folded cloth, and place a heavy weight on top. Press for 24 hours, changing the cloth at intervals.
8. When the purse or rosary case is dry, glue the circular lining (Fig. 2), finished side up, to the inside bottom of the case. Press until set. The purse will then snap open with the pressure of the hand (Fig. 3).

BOYS' AND GIRLS' LEATHER BELTS

MATERIALS

Leather: Heavy leather from a lady's discarded purse or leather jacket for the belts in Plate 8. Felt from old hats.

Buckles, Snaps, or Ties: Buckles from a lady's or man's discarded belt (Figs. 4 and 6). Snap fasteners may be used on felt belts (Fig. 5). Figure 9, also of felt, requires long strips of felt cut from a hat brim (Fig. 10). A jeweled clip will make an attractive buckle for either belt (Fig. 12).

Beads and Sequins: Wooden or plastic beads for the ends of the ties (Fig. 9). Sequins and seed beads strung on the stitching thread, give a sparkling touch (Fig. 6). Nailheads from an old scarf are shown in Figure 5.

Other Materials: Paper for patterns, glue or clear nail polish, and wax for the leather.

TOOLS

Pencil, compass, and ruler for making patterns; razor blade; metal-edged ruler; scissors or pinking shears; needle and thread; and

BOYS' & GIRLS' LEATHER BELTS

made from
DISCARDED LEATHER PURSES OR OLD FELT HATS
IN BRIGHT COLORS.

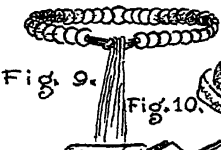

Fig. 9.



Fig. 10.

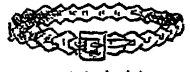

Fig. 11.

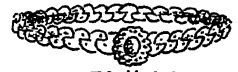

Fig. 12.

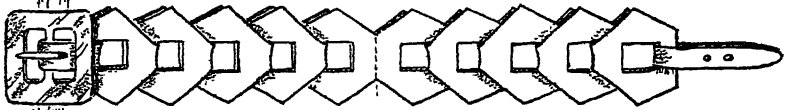

Fig. 4.

← BEADS & KNOTS.

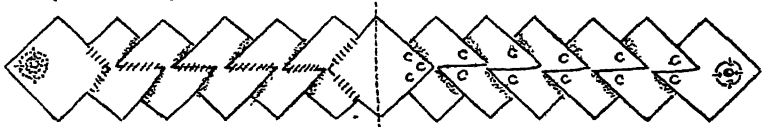

Fig. 5.

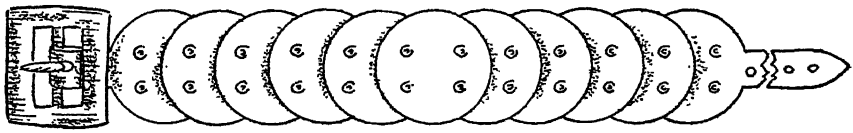
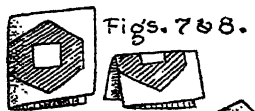

Fig. 6.



Figs. 7 & 8.



Fig. 3.

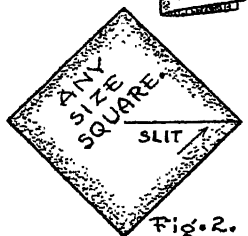

Fig. 2.

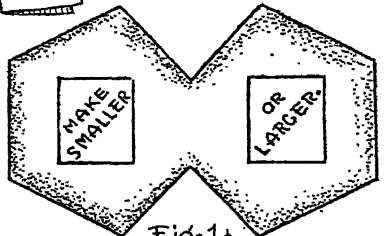

Fig. 1.

MAKE PATTERNS (Figs. 1-2-3) FOR ABOVE BELTS.

leather punch or paper punch for making holes in either leather or felt (Figs. 4 and 6).

PROCEDURE

1. Rip apart the purse with a razor blade. Prepare the leather as in Section 1, "Leather or Plastic Coin Purse," step 1.
2. Make an enlarged pattern of one of the designs in Figures 1, 2, or 3. Figures 7 and 8 show how to make the pattern for Figure 4.
3. On leather or felt, make several tracings of the pattern selected. Cut them with a razor blade or sharp scissors. Place the pieces together and then measure the waistline of the wearer to determine the number of links required for the belt.
4. For Figure 4 two straps will also be needed. One secures the buckle to the belt and is inserted as illustrated with both ends then being sewed together. The second fits the other end of the belt. The strap is doubled and the holes are punched. Stitch, or use rubber cement to glue the strap ends.
5. For the belt in Figure 6, cut the straps as part of the two end pieces. The pieces overlap one half and are sewed together. Use beads, nailheads, or sequins as illustrated.
6. Figures 7 and 8 show how to make the pattern for Figure 1. Figure 4 illustrates the pieces linked together, beginning at both ends of a double thickness, unfolded link in the middle or back. Straps are attached when enough pieces have been linked together to fit the waistline.
7. If a buckle is not available or not desired on a felt belt, the method shown in Figure 9 may be used.

CHILDREN'S BOOKMARKS

MATERIALS

Leather, Plastic, Felt, or Glazed Chintz: Scraps of upholstery leather, white or colored plastic, or leather cut from a lady's discarded purse for the bookmarks in Plate 9. Felt from an old hat is also usable, as well as chintz. Leather for lacing (Plate 1, Fig. 5).

CHILDREN'S BOOKMARKS

made from
LEATHER OR FELT SCRAPS

DECORATE BOOKMARKS WITH COLORED SEQUINS FROM OLD HATS, SCARVES, ETC. BURN DETAILS ON LEATHER WITH BURNING TOOL OR A DARNING NEEDLE STUCK IN THE END OF A STICK. SEW DETAILS ON FELT.

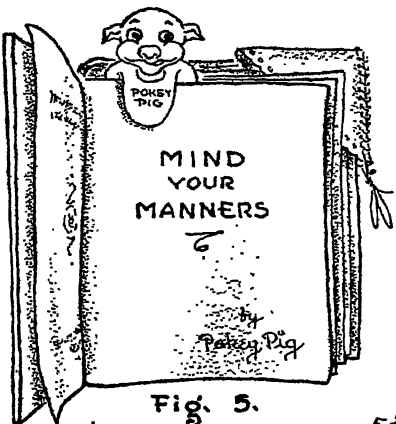

Fig. 5.

Fig. 4.

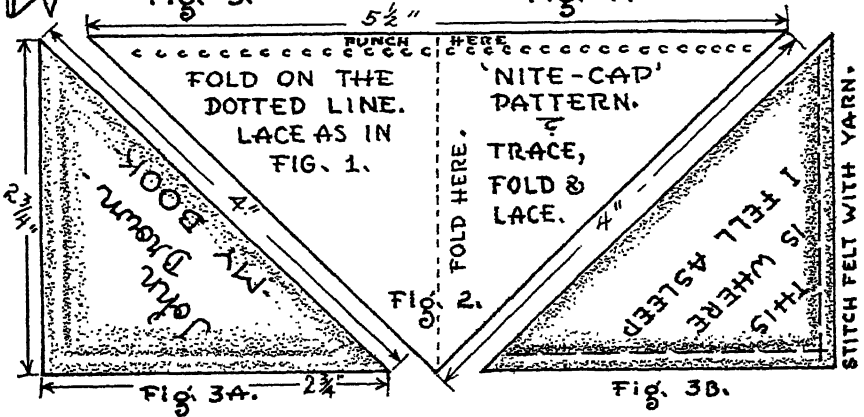

Fig. 3A.

Fig. 3B.

Plate 9

Paints: Colored enamels, car touch-up paints, or nail polish.

Sequins, Beads, and Lacing: Bright-colored sequins, beads, or buttons for animal eyes; colored plastic fishline, yarns, or fancy cords to be used for lacing the "Nite-cap."

Other Materials: Paper for patterns, glue or clear nail polish, and wax for the leather.

TOOLS

Pencil for drawing patterns, razor blade and metal-edged ruler, paper punch, scissors, and an electric burning tool if desired.

PROCEDURE

NOTE: Since this project is for the third-grade level and above, the procedure is presented accordingly.

1. Redraw and enlarge the pattern in Figure 4 and trace it onto cardboard. Also draw and cut the pattern in Figure 2 from cardboard. Allow the children to use the cardboard pattern for tracing on the material of their choice.
2. On leather, use a burning tool or car touch-up paint with a fine brush to draw the animal features, except the eyes (Fig. 4). Attach sequin eyes with glue, or sew buttons or beads.
3. Fold and punch the bookmark in Figure 2 as illustrated. Lace as in Figure 1, or sew with colored yarns as pictured in Figure 3b. Figure 1 is laced with plastic fishline, the edge is scalloped, and a border of beads or sequins is sewed to the material. Felt may be handled in the same manner. Chintz should be sewed as illustrated in Figure 3b.
4. Burn or print with thin enamels the inscription printed on either Figure 3a or 3b if leather is used. Use enamels only on felt or plastic.

"SHOWER" BABY SHOES

MATERIALS

Leather and Felt: White or pastel shades of kid leathers from a lady's discarded purse or doeskin from opera gloves for the baby shoes in Plate 10. White or pastel-colored felt from sports hats.

"SHOWER" BABY SHOES

made from
 WHITE DOESKIN OR KID OPERA LENGTH GLOVES
 OR SCRAPS OF SOFT FELT-
 EDGED WITH PINKING SHEARS.

MAKE PATTERNS
 & PIN
 TO LEATHER
 BEFORE CUTTING.

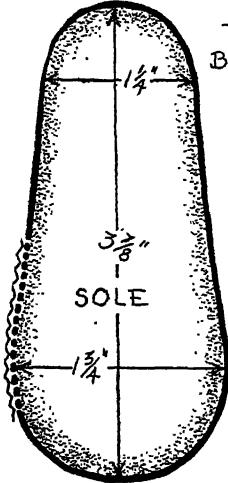

Fig. 2.

TO LEATHER
 BEFORE CUTTING.

STITCH TOGETHER
 (INSIDE OUT.)

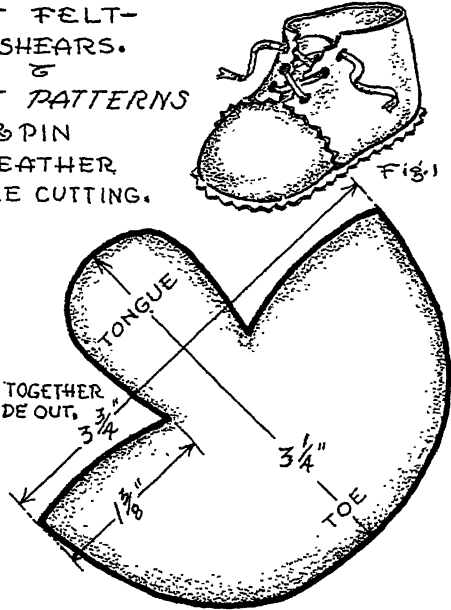

Fig. 3.

IF PINKED, DO SO ONLY ON THE
 FIGURES 2 & 4.

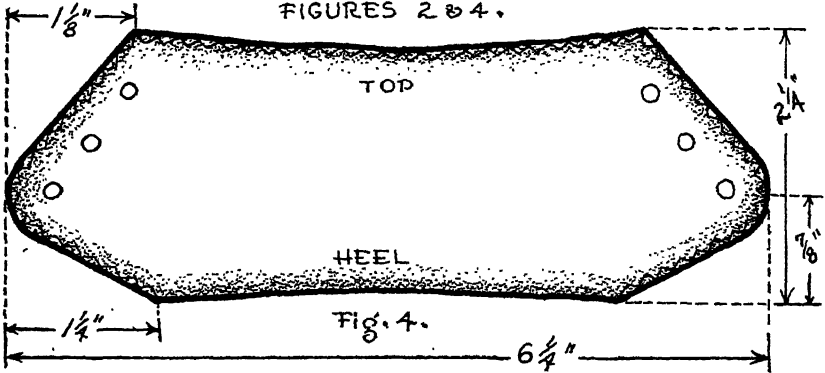

Fig. 4.

Threads and Shoelaces: Fine cotton threads, the same color as the material, or embroidery silk in a contrasting color for stitching. Crochet or embroidery silk, yarn, or ribbon for shoelaces.

TOOLS

Pinking shears or plain scissors, and a small and medium-size needle.

PROCEDURE

1. Using a razor blade, rip the leather purse or gloves at the seams. Clean the leather or felt with cleaning fluid or wash the felt with soap in cool, soft water. Stretch the material with pins on a clean board. Remove the leather from the board and stretch it gently with clean fingers, a small area at a time. Use either surface of the leather as the outside of the shoe.
2. With paper and pencil draw the patterns in Figures 2, 3, and 4.
3. Cut and pin the patterns to the felt, if used. Use scissors or pinking shears for felt and cut just outside the line, as indicated in Figure 2. Depending upon the craftsman's choice, all edges may be pinked or cut entirely with plain scissors. Another alternative is to pink all edges except the heel of Figure 4 and the toe of Figure 3.

NOTE: Do not pin patterns to thin leathers because pin holes will show. If leather is used, lay the patterns on the leather and trace around the edges with the sharpened point of a piece of chalk.

4. With a paper or leather punch, make holes for lacing as illustrated in Figure 4.
5. Decorate the baby shoes with embroidery work, ribbon bows, or designs worked with small glass beads.
6. Stitch plain edges of thin leathers with a fine needle, using self-colored thread. When the material has been pinked, choose silk embroidery threads or fine yarn in pastel colors. Use a blanket stitch to add interest. The same process should be used in sewing felt. A medium-size darning needle will facilitate stitching here.
7. Make the shoelaces harmonize with the stitching. They can be made of colored silk ribbons or embroidery silks or yarns crocheted to the proper length.

SECTION 2 — WOOD

DECORATIVE CARVING BOARD

MATERIALS

Wood: For the carving board (Plate 11) you can use scrap oak, birch, fir, or white pine from the kindling pile. You can also use ends of orange or apple crates, or board ends from shelving or $\frac{3}{4}$ -in., 5-ply paneling wood. Ends of apple boxes and orange crates are recommended for the beginning craftsman because they are available at no cost. Hardwood, such as oak or birch, is more durable and beautiful. A carving board is a household necessity and makes an attractive gift as well. Make several in different designs and have them available for home use or as gifts.

Paints: Water colors or show card paints, colored enamels, clear shellac, and clear spar varnish.

Other Materials: Paper for patterns, sandpaper, steel wool, and furniture or car wax.

TOOLS

Pencil and paper for patterns, scissors, coping saw, plane (if necessary), drill, wood file, electric wood burning tool, or a large nail that can be heated and held with pliers.

PROCEDURE

1. Using paper and pencil, draw a decorative fish, turtle, etc., for a meat or fowl carving board (Figs. 1 and 3). A sheaf of grain is effective and appropriate for a bread or pastry slicing board (Fig. 4). Make the design in outline only; then cut out the pattern for tracing on the wood.
2. Sand the board to a very smooth surface on both sides. Trace the pattern on one side of the wood. Cut on the outline with the coping saw. Sand the edges smooth. Cut grooves on the edge of the board with a wood file (Fig. 2) to suggest the edges of the turtle's feet and the fish fins (Figs. 1 and 3).

DECORATIVE CARVING BOARD

Made from WOOD SCRAPS.
 USE A COPING SAW, FILE, SAND-
 PAPER, BURNING TOOL, LACQUER
 OR ENAMEL, CLEAR SHELLAC,
 AND FURNITURE WAX.

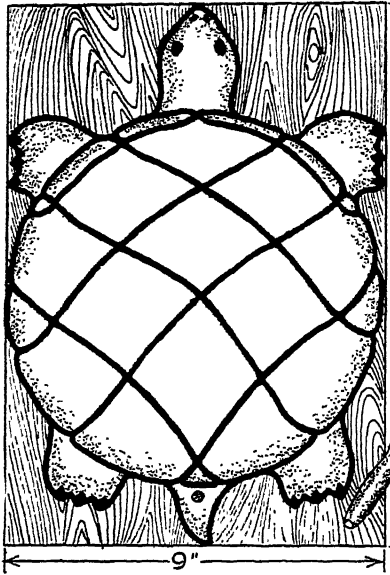

Fig. 3.

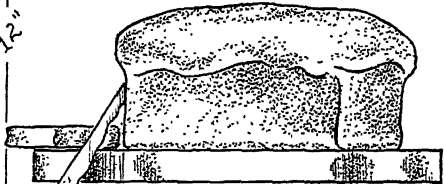

Fig. 4.

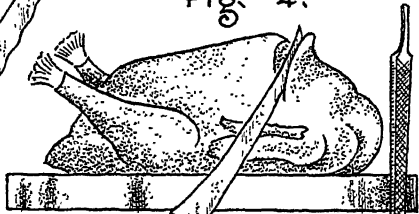

Fig. 2.

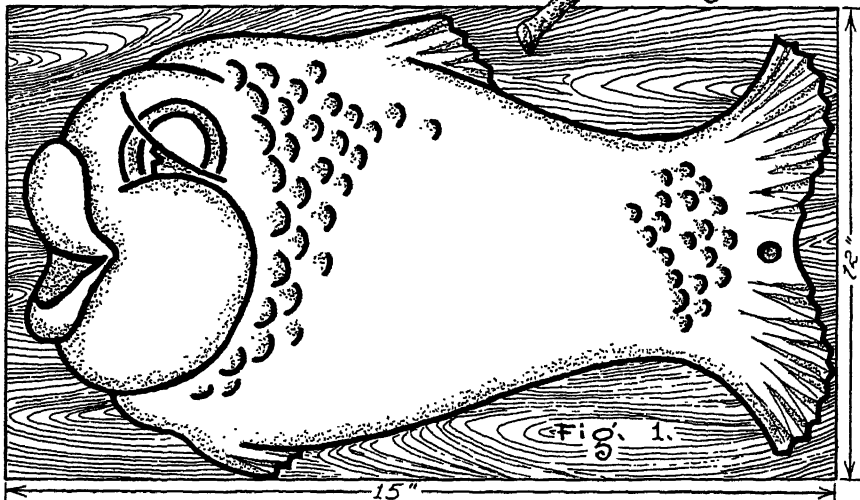

Fig. 1.

Plate 11

3. One side of the board will be decorated. The other will be used for carving and cutting and hence will be left unfinished except for sanding. Figures 2 and 4 illustrate uses for the decorative carving boards. Now trace details of the design on the board. Burn them in outline with the burning tool. If the design is to be painted, use water colors, show-card paint, or enamel. If desired shade the burned outlines with color. Allow paint to dry thoroughly. See Figures 1 and 3 for shading.
4. Apply two coats of thin, clear shellac, sand lightly, then apply one or more coats of clear spar varnish.
5. Steel wool lightly. Give the varnished surface a coat or two of furniture or car wax for a high gloss.

LAMP, FRUIT BOWL, AND JEWEL BOX

MATERIALS

Wood: Wood for these three craft projects (Plate 12) can be found in most homes. Use a round or square leg from an old-fashioned dining table for the lamp base. The average over-all height of the table lamp (Fig. 1) can be about 26 in. Make the bottom of the shade slightly overlap the top of the lamp base. Most homes have at least one wooden chopping bowl. A covered wooden shaving-soap bowl can be fashioned into an attractive jewel or trinket box.

Lamp Shade, Wallpaper, and Gift Package Tapes: Salvage that old lamp shade relegated to the attic. Dismantle and cover it with wood-grain wallpaper. For border designs use the decorative plastic or paper tapes left over from Christmas gift wrapping.

Fixtures and Paints: Dismantle an old discarded lamp and use the fixtures on the lamp project. Colored enamels or car touch-up paint may be used to apply the designs to a wooden fruit bowl or jewel box. A combination of burned outline and space filling with color is very interesting.

Other Materials: Paint remover, soap to clean the bowl, sandpaper, wax, clear shellac, and varnish.

TOOLS

Saw. A wood-burning tool may be desired for both the bowl and jewel box.

PROCEDURE

Lamp

1. Remove old paint or varnish from the wood. Sand the wood and shellac it. Give the wood a coat of clear varnish or furniture wax, if desired.
2. Remove the old covering from the lamp shade and use it for a pattern to cut the wallpaper covering. Attach the new covering to the frame with bias tape and glue. Apply bands of colored paper tape as shown in Figure 2.
3. Assemble the lamp as the metal parts indicate.

Fruit Bowl

1. For the bowl in Figure 3, scrub the stains from the wooden chopping bowl.
2. Lay the bowl on paper, trace around it, and develop a design to fit the bowl. Trace the design into the bowl.
3. Make the outline of the design with a burning tool. Sand the bowl light and paint the designs.
4. Apply a second coat of shellac and wax the bowl.

Jewel Box

Treat the jewel box (Fig. 4) like the fruit bowl; or if desired, merely paint it with enamels and then shellac and wax it.

LAMP-~~fruit~~ BOWL-JEWEL BOX

made from

CASTOFF LAMP SHADE - CHOPPING BOWL - AN OLD TABLE LEG & A SHAVING-SOAP BOWL.

TOOLS & SUPPLIES:

SAW - SANDPAPER & STEEL WOOL - OLD LAMP FIXTURES - AN OLD LAMP SHADE - AN OLD TABLE LEG - AN OLD CHOPPING BOWL - A SHAVING SOAP BOWL - ENAMEL & WALLPAPER.

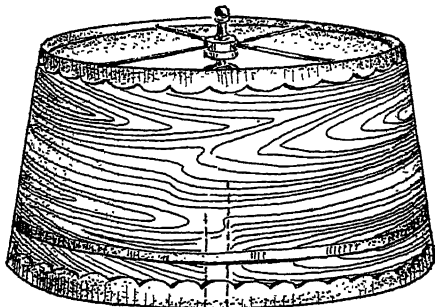

Fig. 2.



Fig. 3.



Fig. 4.

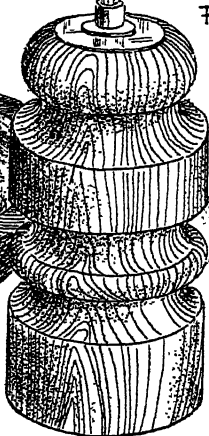

Fig. 1 IS LEG FROM DISCARDED, OLD-FASHIONED TABLE.

METAL NAME PLATE FOR DESK

MATERIALS

Wood: For the desk plate, use scrap oak, birch, or white pine, 2 by 2 by 8 in. (Plate 13, Fig. 1). For the door plate (Fig. 2), a piece of plywood 2 by 4 in. can be used.

Metal and Nails: Modeling metal can be purchased at school supply stores; buy metal slightly larger than needed and trim it to size (Figs. 1 and 2). Mount the metal with small brass nails.

Other Materials: Paper for patterns, paper towels for a bed on which to work the design into the metal (Fig. 5), sodium sulphide to color copper, sandpaper, clear shellac, and furniture wax.

TOOLS

Pencil, ruler, and scissors for making patterns (Fig. 4); cuticle stick for modeling metal (Fig. 5); and hammer, saw, and plane for shaping the wood (Fig. 3). A compass point will pierce the nail holes in the metal (Fig. 1).

PROCEDURE

1. Cut the wood to size and plane it. Sandpaper all surfaces and apply two coats of shellac, sanding between coats.
2. Make the pattern for the metal, cutting it from $\frac{1}{8}$ to $\frac{1}{4}$ in. smaller on all sides than the wood block on which it will be mounted (Fig. 4). Lay the pattern on carbon paper with the carbon side up. With a ruler and pencil, draw lines parallel to the sides of the pattern and about $\frac{1}{4}$ in. from them, thus making a panel. Within this panel write or print the name, house, or room number desired. The name on the pattern will be found in reverse on the back of the paper.
3. Lay the metal on a sheet of glass and polish it brightly with steel wool. With a cloth, apply sodium sulphide generously over the metal. When the desired color appears, submerge the metal in cold water to stop the coloring action.
4. Lay the pattern with the reverse side up on the uncolored side of

METAL NAME PLATE *for* DESK

made from

WOOD SCRAPS FROM THE KINDLING PILE AND MODELING METAL PURCHASED AT SCHOOL SUPPLY STORE.

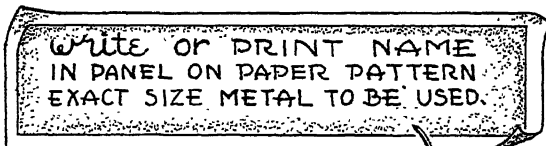

Fig. 4. PAPER PATTERN.

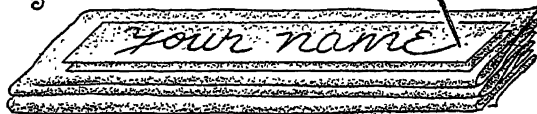

Fig. 5. TRACE PATTERN ON METAL WITH BED OF 3 PAPER TOWELS OR NEWSPAPERS UNDERNEATH.

TOOLS & SUPPLIES:

PAPER & PENCIL FOR PATTERNS - RULER - SCISSORS - BRASS-HEADED NAILS - A CUTICLE ORANGE STICK - SAW - PLANE - SANDPAPER - STEEL WOOL - NEWSPAPER - HAMMER - PUNCH - SHELLAC - VARNISH & PHOTOGRAPHER'S SEPIA TONER FOR COLORING METAL.

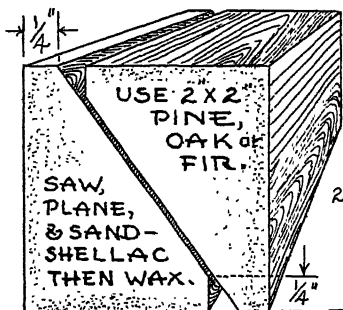

Fig. 3.

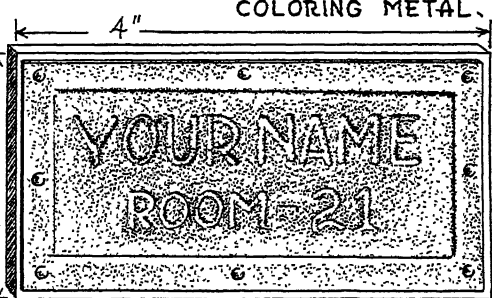

Fig. 2. DOOR PLATE.

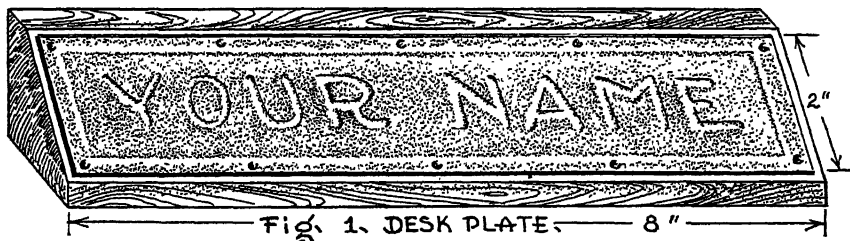

Fig. 1. DESK PLATE. 8"

- the metal. Place the pattern and metal on a bed of three folded paper towels or newspaper (Fig. 5). Trace the design on the metal with an orange stick or some other sharp stick.
5. Remove the pattern and work the design deeper into the metal with the stick. Then turn the metal right side up on a sheet of glass and smooth out the background around the letters with a teaspoon. Steel wool lightly over the raised design.
 6. Place the metal on the wood, pierce nail holes in the metal with a compass point, and nail the plate to the wood. Varnish both the metal and wood. Steel wool lightly and wax the article.
 7. Glue felt to the bottom of the desk plate.

SPOOL TOY FOR BABY

MATERIALS

Spools: For the toy in Plate 14, thread spools of all sizes, also spools from an adding machine or cash register for body, arms, and legs.

Beads: Wooden or glass beads to form the joints of the toy (Fig. 1).

Plastic Lacing: Use a strong lacing which will withstand boiling when the toy becomes soiled (Fig. 10).

Decorating Materials: Water colors or wax crayons (Figs. 7 and 8) for decorating the spools, clear shellac, and spar varnish.

TOOLS

A saw for separating spool ends for a hat or collar (Fig. 3), and paper clips to hold spools for painting the toy and hanging to dry (Fig. 2).

PROCEDURE

1. From some office or bank, secure six adding-machine spools for the limbs of the toy. Cut two in half for the arms (Fig. 1). Use an extra large spool for the body and one large enough for the head. Others of varying size may be used according to the craftsman's originality. Arrange the spools in the likeness of the human figure, with longer spools for the legs. Use large spools for the body and

SPOOL TOY FOR BABY

made from

THREAD SPOOLS, ADDING MACHINE SPOOLS,
LARGE WOODEN OR GLASS BEADS AND
PLASTIC LACING.

TOOLS & SUPPLIES:

WATER COLORS,
WAX CRAYONS,
CLEAR SHELLAC,
SPAR VARNISH,

-BRUSH -
SANDPAPER,
PAPER CLIPS,
STRING,
SAW.



Fig. 2.

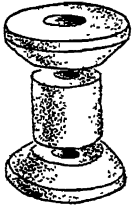

Fig. 4.



Fig. 6.



Fig. 5.

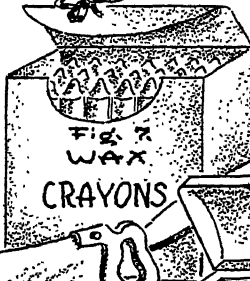

Fig. 7.

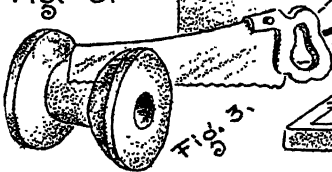

Fig. 3.

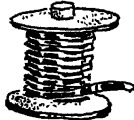

Fig. 10.

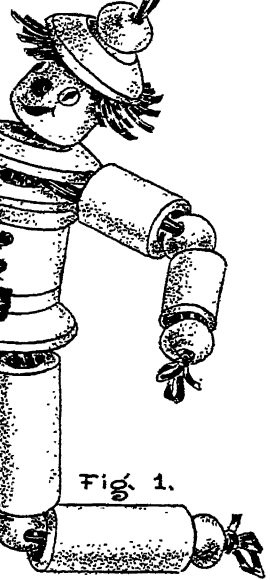

Fig. 1.



Fig. 9.

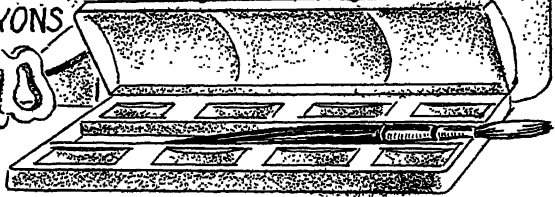

Fig. 8.

Plate 14

- head, and short ones for the arms. For a collar or a hat, saw off one end of a large spool, and turn it upside down for the collar. The remaining part may be used for a hat over the "head" spool.
2. Sand all spools.
 3. Decorate the spools using water colors to paint them to resemble clothing. Wax crayons, nail polish, or a burning tool can be used to make facial features and other decorations.
 4. Straighten paper clips and insert them into the spools to hold them when applying the finish and to hang them on a line to dry. Apply a coat of clear shellac and let it dry. Sand the spool lightly and apply spar varnish.
 5. String each part of the toy separately with plastic lacing. Use beads, preferably wooden ones, for hands, feet, knees, and elbows. String the ends of the lacings for both legs up through the body and join with the lacings of both arms. Lace all ends through the head. Hair may be made from short strands of colored yarn secured to the lacing between the head and hat. Tie above the hat and leave a loop handle.

SALT AND PEPPER SHAKERS AND SPORTSWEAR BUTTONS

MATERIALS

Spools, Beads, Buttons, and Plastic Cord: For sports buttons, thread spools of all sizes. Small decorative buttons or beads, and plastic fish-line or plastic lacing (Plate 15, Figs. 1, 2, and 3).

Adding-Machine Spools and Large Decorative Buttons: Attractive salt and pepper shakers can be made from adding-machine or cash-register spools with fancy buttons for tops (Fig. 4).

Cash-Register Spools and Plywood: Scrap plywood with cash-register spool handles make a clever cocktail tray (Fig. 7).

Other Materials: Sandpaper, clear shellac, colored nail polish, spar varnish, glue, and furniture wax.

SPORTSWEAR BUTTONS



MADE FROM SAWED OFF SPOOL ENDS



Fig. 1.

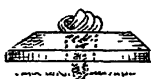

Fig. 2.

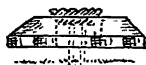
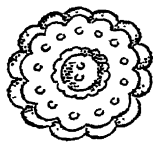

Fig. 3.

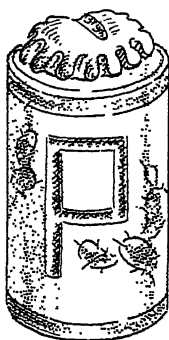
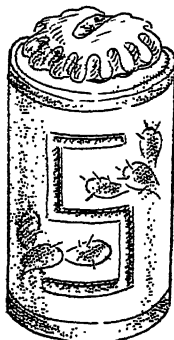

Fig. 4.

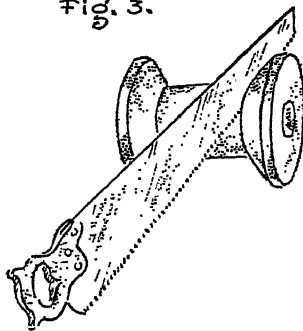

Fig. 5.

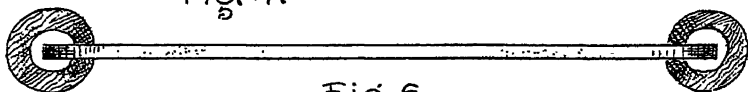

Fig. 6.

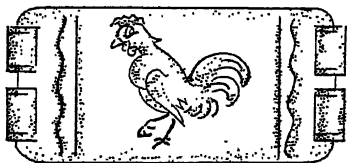

Fig. 7.

**SALT & PEPPER
SHAKERS
AND
COCKTAIL TRAY**

FROM SPOOLS & WOOD SCRAPS.

Plate 15

TOOLS

Saw, wood file, burning tool, and paper clips.

PROCEDURE

Decorative Buttons

1. Saw off the ends of the spools. Form the cogged or scalloped edges with a file (Figs. 1 and 3).
2. Sand the buttons and decorate them with a burning tool, colored nail polish, or other desired media. Apply a coat of shellac and hang the buttons to dry using paper clips. Sand and wax the buttons.
3. Sew the buttons to the garment through a bead or small button placed over the spool hole (Figs. 1 and 3). For the button in Figure 2, use a large, fancy knot of plastic cord or fishline with a loop for sewing to the garment.

Salt and Pepper Shakers

1. Sand two cash-register spools for the shakers in Figure 4.
2. Decorate with a burning tool or enamel. Apply one coat of clear shellac, sand lightly, varnish, and hang up to dry.
3. Glue interesting buttons to the top of each. Fill with salt and pepper and attach plastic tape to the bottoms.

Cocktail Tray

1. Use four adding-machine spools for handles (Fig. 6). Saw a slot in each spool, the thickness of the plywood. Sand spools smooth. Apply a coat of clear shellac. Hang the spools to dry on unfolded paper clips. Sand again lightly.
2. Shape the plywood for the tray with a fine file. Round the corners with a wood file. Sand the surfaces smooth and apply the design with a burning tool or paint. When dry, apply a coat of clear shellac. Allow the shellac to dry and sand again lightly.
3. Glue the four handles in place as illustrated in Figure 7. When the tray is assembled, apply one or more coats of spar varnish.

RUSTIC BOOK ENDS

MATERIALS

Wood: Large dry branches, trunks of small trees, or fireplace chunks of birch, ash, or elm, with or without the bark (Plate 16).

Metals: Scrap aluminum, heavy flashing copper, or galvanized metal.

Felt: Scrap felt from ladies' discarded hats for the base of the book ends.

Other Materials: Sodium sulphide to color copper if desired, sandpaper, steel wool, nails or screws, clear shellac, and spar varnish.

TOOLS

Saw, hammer, screw driver, tin snips, and a metal file.

PROCEDURE

NOTE: Figures 4a and 5 show book ends with a metal base. The metal can be fastened with screws or nails. A pair of book ends cut from a single piece of birch is illustrated in Figure 6. Carving on Figure 7, if desired, is done with a sharp knife.

Diagonal slabs are used in Figures 1a and 1b. Cut a slab about $\frac{3}{4}$ in. thick and 8 in. long from the dead trunk or branch of a small tree.

Figure 3b shows how a large chunk of birch or elm can be sawed in quarters. This will make two pairs of book ends. Figure 3a shows how they are used.

A novel single book end is shown in Figure 2. A strip of heavy flashing copper, about 15 in. long and the width of the wood, is coiled around a wooden dowel held in a vise. The copper is polished with steel wool and attached to the wood with screws. It can be colored with sodium sulphide if desired.

1. Saw the wood for the book end chosen and sand the ends smooth. Fill the end grain with four or six coats of shellac. Cover the bark with one or more coats of shellac.
2. Cut the metal base, allowing 5 in. in addition to that required for

attaching the metal to the wood. Cut the metal slightly narrower than the wood piece.

3. File all metal edges. Use steel wool on all surfaces and edges. Punch the holes in the metal with a nail and hammer before nailing it to the wood.
4. When the book ends are assembled, apply one or more coats of varnish to both the wood and metal. Allow the varnish to dry and glue felt to the bottom of the metal.

NOTE: In addition to the wood projects illustrated and explained in this section, another one might be suggested. It is a project that requires little in the way of fabrication. The chief effort involved consists of a little searching, mounting, and finishing. On hikes and strolls in the countryside and on the beach, be on the lookout for parts of dead branches and limbs shaped like familiar objects such as dogs or birds. Thus for example, you might come across a knotted elbow of a branch resembling the head of a collie.

Carefully cut it off, screw it to a wood base, clean it if necessary, and finish with shellac, varnish, or lacquer.

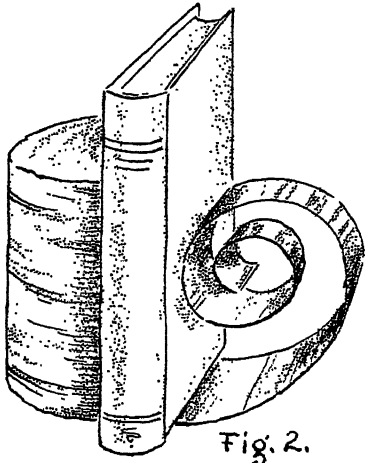

Fig. 2.

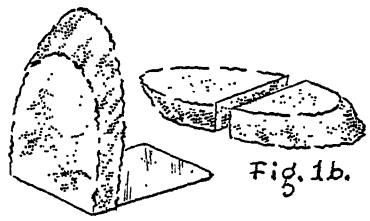

Fig. 1a.

Fig. 1b.

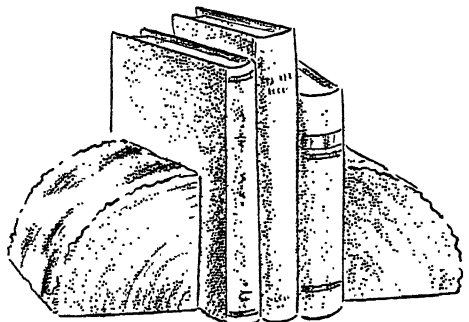

Fig. 3a.

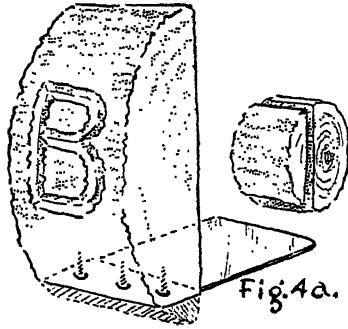

Fig. 4b.

Fig. 4a.



Fig. 3b.

RUSTIC
BOOK ENDS

MADE FROM BIRCH & PINE
CHUNKS AND TIN CANS.

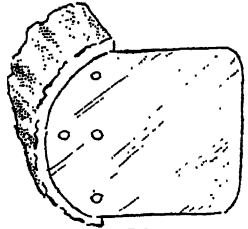

Fig. 5.

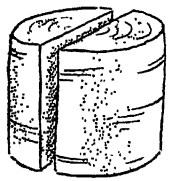

Fig. 6.

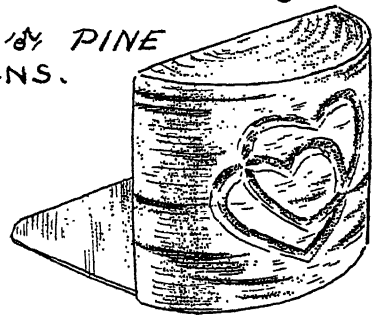

Fig. 7.

RUSTIC DOOR KNOCKER

MATERIALS

Wood: For the base of the knocker (Plate 17), use a slab of wood cut from the trunk or a branch of a dead pine, birch, oak, ash, or elm tree. Dig for a sapling root of the proper size to be used as a knocker.

Other Materials: Use a large nail for the hinge and two long screws to attach the knocker to the door. Sandpaper, clear shellac, and spar varnish.

TOOLS

Saw, cold chisel or wood chisel, and a drill.

PROCEDURE

1. Cut a slab about $\frac{3}{4}$ in. thick and about 8 in. long from the dead trunk or branch of a small tree (Fig. 3).
2. Make the slot for the knocker. It should be a little wider than the knocker so that it will swing freely. Saw at the sides and chip out the wood with a chisel.
3. Sand both the slab surface and the edges of the slot. Do not disturb the bark.
4. Peel the root of the sapling and let it dry. Then sandpaper it and bore a hole for the nail.
5. Give both the slab and the knocker 2 or 4 coats of clear shellac and 1 or 2 coats of spar varnish.
6. Secure the knocker in the slot and attach the completed knocker to a door with the two long screws.

RUSTIC DOOR KNOCKER

MADE FROM

PINE OR BIRCH "SLICES"
AND SAPLING ROOTS

WITH

"BRANDED" DECORATIONS

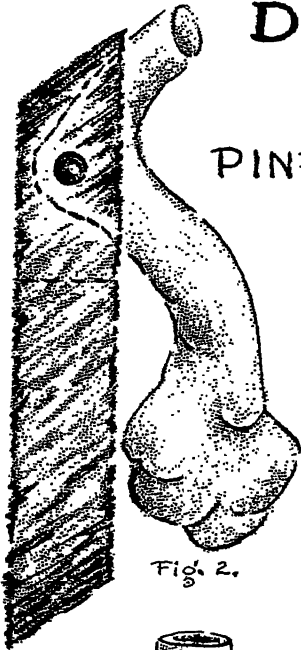

Fig. 2.

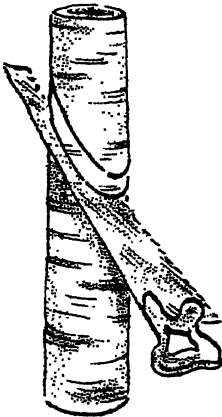

Fig. 3.

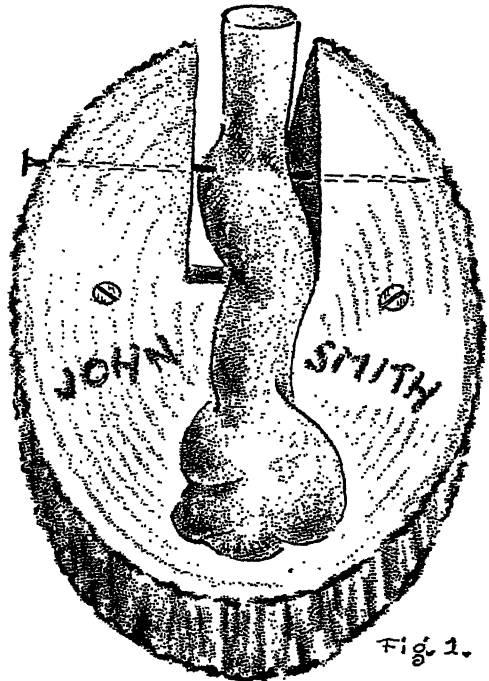

Fig. 1.

Plate 17

RUSTIC WHATNOT

MATERIALS

Wood: The rustic whatnot is made from slabs of wood cut from the trunk or branch of a dead pine, birch, oak, ash, or elm tree (Plate 18). Note that the back of the whatnot is sawed on the diagonal, while the shelf is cut straight through the branch or trunk (Fig. 1).

Hangers, Screws, Nails: Hang the finished article with a leather bootlace or a heavy fish cord. Picture hangers may also be used. Two nails or screws will join the shelf to the back piece.

Bric-a-Brac: Since this shelf is intended primarily as a wall decoration for a summer cottage or a cabin at camp, natural objects are suggested for display on the whatnot. Sea shells (Fig. 1), fossils, or rock crystals are excellent. The whatnot would also be useful to hold a candle (Fig. 2).

Other Materials: Sandpaper, clear shellac, and varnish.

TOOLS

Saw, hammer, brush, and drill or hot poker for boring holes.

PROCEDURE

1. Saw a slab of wood $\frac{3}{4}$ in. thick and 10 to 12 in. long as described above. Saw the vertical piece diagonally (see the preceding project, "Rustic Door Knocker," Plate 17, Fig. 3). Saw the shelf straight from the same piece from which the back has been cut so that both pieces will be the same width. Saw the shelf in half or cut off about $\frac{1}{8}$ to $\frac{1}{4}$ in. from one edge before fitting the two pieces together.
2. Sand all surfaces to a smooth finish. Do not disturb the bark. Bore a large hole for the hanger and two small ones for the nails or screws. If holes are not bored, the wood may split.
3. Apply four to six coats of shellac, sanding between coats.
4. Assemble the two pieces.
5. Apply one or two coats of clear varnish over the entire article, including the bark. When dry, insert the leather thong.

Rustic[®]

WHATNOT

MADE FROM

DIAGONALLY SAWED
ASH, PINE, OR BIRCH SLABS

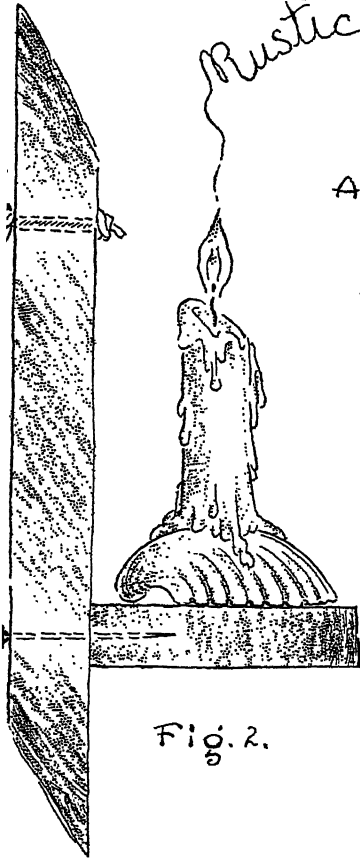

Fig. 2.

HUNG WITH
LEATHER THONG.

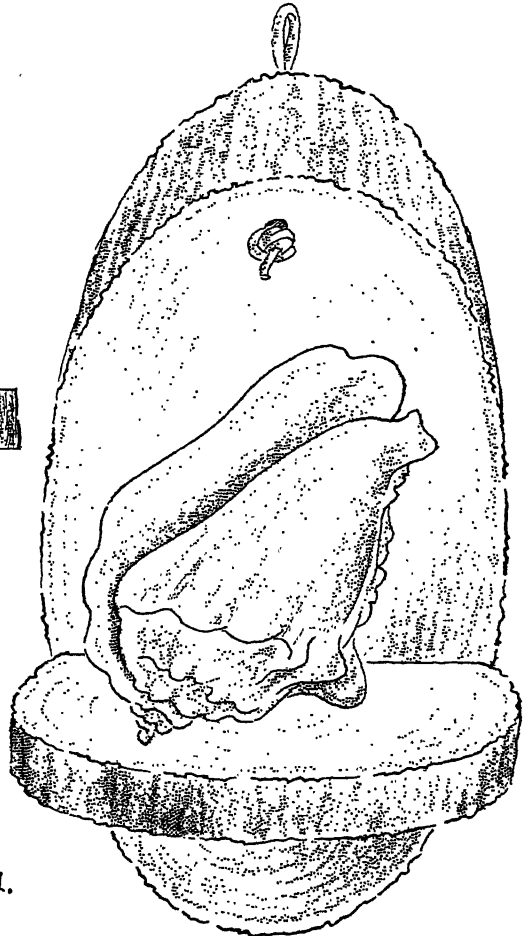

Fig. 1.

Plate 18

RUSTIC BIRDHOUSE WITH BATH

MATERIALS

Wood, Wire, and Nails: This project is suggested for a summer cottage or summer camp. Even hikers and campers might like to erect such a setup in the woods. The necessary dead tree stump is not always situated near the cabin. Having located the tree, find also the wooden tub or cheese box for the framework for the birdhouse (Plate 19, Fig. 1). Also collect the small straight branches to cover the house, a large piece of birchbark or metal for the roof, bailing wire, and small nails.

Bath: Make the rustic birdbath from an old garbage can lid or a circular metal tire cover (Fig. 2). Wild flowers potted in painted tin cans or earthen pots are very attractive (Fig. 3).

Paints: A bit of paint for the flowerpots and the bath may be desired. The interior of the bath may be painted a light blue to reflect the sky. Use brighter colors for the potted plants.

TOOLS

Saw, hammer, and tin snips.

PROCEDURE

1. Prepare the tree by sawing odd limbs to fit the needs of either the house, the bath, or the potted plants.
2. Cut the small branches to the desired length (arrange for a door, Fig. 1), and use small nails to attach the branches to the box or tub base. Use any available wire to keep the branches in place.
3. Before attaching the roof, nail the floor of the house to the trunk of the tree. Then cut the birchbark or metal to make an overhanging roof (Fig. 1).
4. Paint the bath (Fig. 2) and flowerpots (Fig. 3) and allow them to dry. Fill the pots with wild flowers and arrange them and the bath in their respective places on the tree. Use the stump with or without the bark.

TREE STUMP
RUSTIC BIRDHOUSE
with **BATH**

MADE FROM

TWIGS BOUND WITH
 BAILING WIRE TO CHEESE-
 BOX--ROOFED WITH
 BIRCHBARK.~

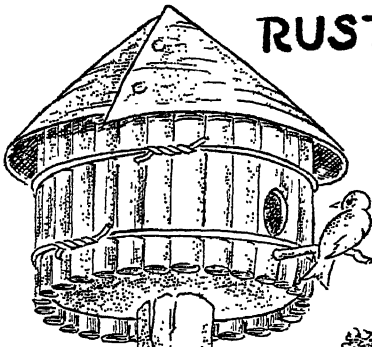

Fig. 1.



Fig. 3.



A DISCARDED LID
 FROM A REFUSE CAN
 FOR BIRDBATH.



Fig. 2.

POTTED PLANTS
 ADD NATURAL
 COLOR.

Fig. 4.

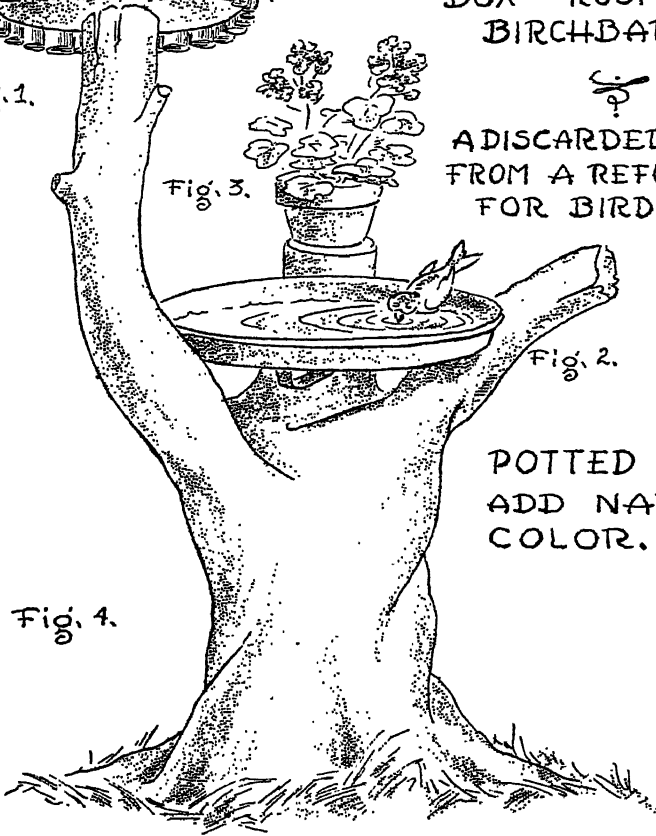

Plate 19

CAMP COMFORT

MATERIALS

Barrel and Branches for the Doghouse: A heavy, hardwood barrel such as those used for shipping pickles, etc.; be sure to obtain the head or cover of the barrel (Plate 20, Fig. 2). Twigs or branches longer than the barrel will be needed to make the roof.

Vine Trellis

Two long branches from a live tree or from one recently trimmed of sufficient size to make a trellis for a specific spot (Fig. 3). Other branches varying in size and length for the crosspieces and added decorations.

Window Awning and Flower Box

Enough medium sized branches to cover an awning of specific measurements, and additional pieces to use as a framework (Fig. 1). Straight dried branches are best and can be split in half or used in the round, as desired. An apple box or an orange crate will do for the framework of the flower box, and enough small branches of sufficient length to cover the box. Two large branches can be used for brackets to support the flower box.

TOOLS

A saw, hammer, and nails in a variety of sizes will be required for these three rustic projects.

PROCEDURE

Doghouse

1. Cut a door to accommodate the "occupant" in the lid of the barrel (Fig. 2).
2. Nail the lid in place.
3. Saw the branches for the roof to length, nail them together, and place over the barrel.
4. Place the doghouse on two small logs or stones to keep the floor dry.

BARREL & BRANCH
DOGHOUSE

FOR
THAT CAMP
MASCOT

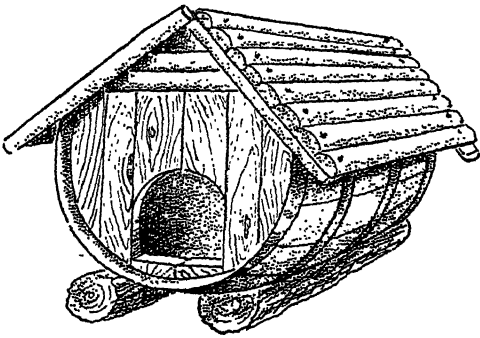

Fig. 2



CAMP COMFORT

VINE TRELLIS

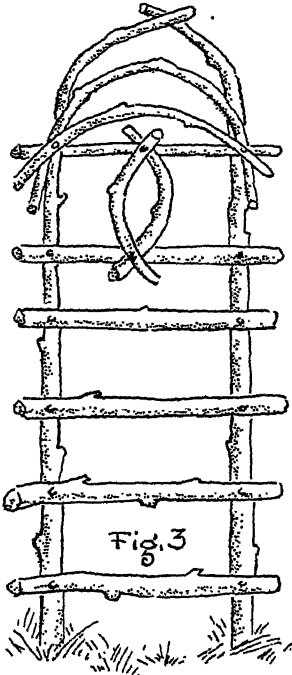

Fig. 3

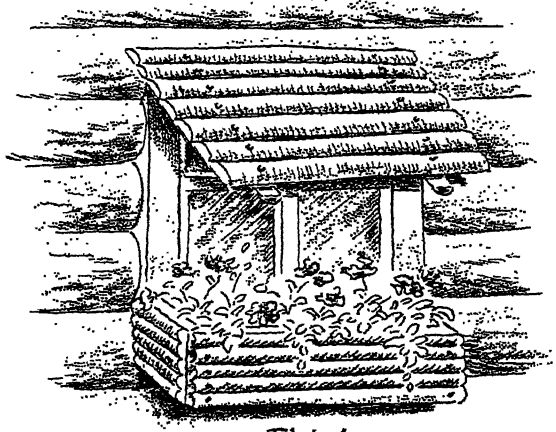

Fig. 1.

SPLIT-BRANCH AWNING
& WINDOW FLOWER BOX.

Plate 20

Vine Trellis

1. As shown in Figure 3, use two branches with bent ends for the uprights.
2. Nail crosspieces at intervals and add a few smaller bent twigs to add interest and design.

Awning and Flower Box

1. Using two pieces of split branches for the brackets, nail across them either split branches or small, round twigs. They should be of lengths that compare to those in Figure 1.
2. Nail or screw the brackets to the window frame.
3. For the flower box, saw an orange crate down the middle lengthwise.
4. Nail small branches to this frame as illustrated in Figure 1.
5. Set the completed box on two branch supports already set in the ground.

SECTION 3 — METAL

CHRISTMAS TREE ORNAMENTS

MATERIALS

Metal: For the ornaments in Plate 21, the tops and bottoms of gold-lined tin cans of any size.

Decorative Materials: Christmas seals, fancy gift wrapping cords, nail polish, sugar or salt, and metallic papers from old Christmas cards or similar source.

TOOLS

Turnkey, can opener, tin snips, pliers, nail, and hammer.

PROCEDURE

Figure 1

Using tin snips or heavy shears, fringe the tops or bottoms of clean tin cans as illustrated. Point the cutting tool toward the center of the lid and cut only to one of the rings. With pliers, twist each piece of fringe one or two turns. Attach a Christmas seal to each side, punch a hole with a nail, and insert the decorative cord for hanging on the tree.

Figure 2

Cut a paper star to fit the piece of metal. Trace around the star with a nail and cut the fringe as illustrated. The solid, shaded parts will fall off. Cut and twist the fringe pieces. Apply circular pictures cut from used Christmas cards, one on each side. Punch a hole and attach a cord for hanging.

Figure 3

This ornament is made the same as that shown in Figure 1, except that the fringe is cut on the diagonal. Cut a star from the colored metallic papers often used on Christmas cards, and mount one on each side of the ornament. Lace fancy cord or ribbon through the fringe, leaving a loop for hanging.

XMAS TREE ORNAMENTS

MADE FROM
TIN-CAN
TOPS

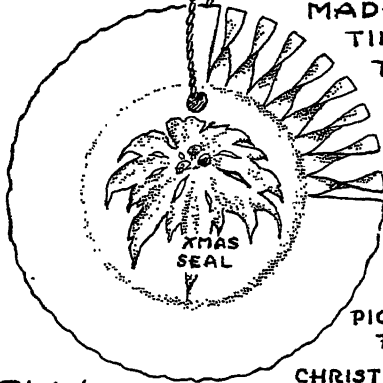

Fig. 1.



Fig. 2.

PICTURES FROM
CHRISTMAS CARDS,
CHRISTMAS SEALS,
AND
METALLIC
PAPERS.

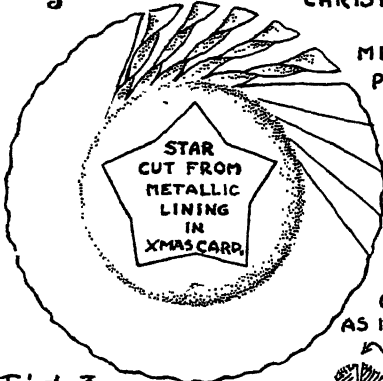

Fig. 3.

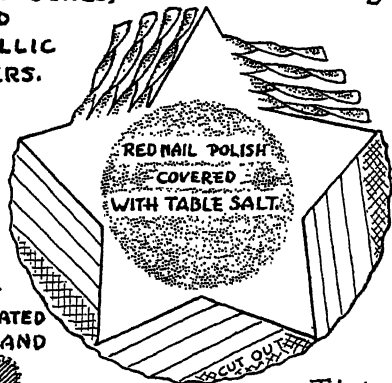

Fig. 4.

CUT
AS INDICATED
AND

INSERT ONE
OVER THE
OTHER.

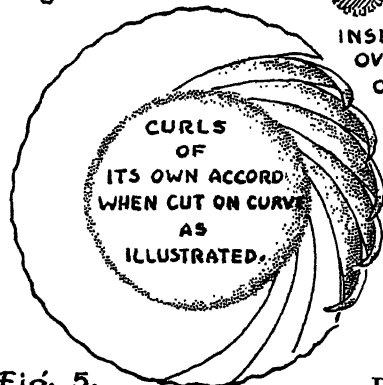

Fig. 5.

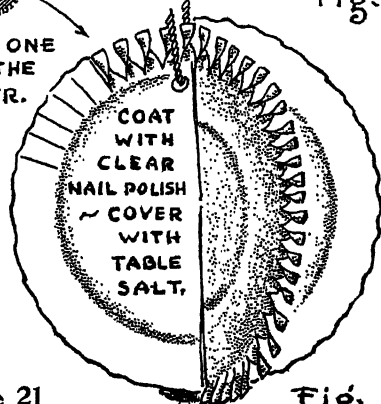

Fig. 6.

Plate 21

Figure 4

Use the same paper star pattern that was used for Figure 2. Cut away the shaded parts and fringe the metal on the diagonal, or parallel to the star points. Twist the metal as indicated. Apply a coat of red or clear nail polish to the circular center of the lid; then sprinkle sugar or salt generously while the nail polish is still wet. Hang as illustrated in Figure 2.

Figure 5

Cut this ornament like the one in Figure 3, with the exception of curving the cutting strokes. The fringe pieces will have a curl instead of the twist, which is made with the pliers. Decorate as desired, or leave plain for variety.

Figure 6

Two can lids are required. After fringing both pieces of metal, slit them a trifle beyond the center as shown in the accompanying illustration. Assemble the pieces in dovetail fashion, decorate as desired, and hang on a tree or in the window.

CHRISTMAS TREE ANGEL

MATERIALS

Metal: A 2-quart or gallon-size tin can, with gold lining if possible, can be used for the angel in Plate 22.

Aluminum metal foil also can be used.

Hanging Cords: Decorative gift wrapping cords, ribbons, or bright embroidery silks.

Angel Faces: Cut a face for the angel from colored magazine pictures. Facial features may be pressed into metal foil with a sharp stick.

Paints and Glue: Colored nail polish or car touch-up paints, and rubber cement or glue.

TOOLS

A turnkey, can opener, tin snips or heavy shears, pliers, and a rolling pin to flatten the metal.

PROCEDURE

1. Using tin snips or heavy shears and a can opener, remove the bottom of the can and cut it down the side at the seam. Then roll the metal flat with the rolling pin.
2. Paint one entire surface, preferably the silver side, with nail polish or car touch-up paint and let it dry.
3. Make a paper pattern of the angel (Fig. 1), and trace it onto the metal with a nail or pin. Cut on all heavy lines as illustrated in Figure 1. Fringe the wings and twist each fringe piece with pliers. Note the strip along the right wing which is to be cut and curled for a halo as pictured in Figures 3 and 4.
4. If desired, place a birthday candle in one of the angel's hands by curling the metal around it (Fig. 2).

CAUTION: The candle is for decoration; never light it because of the danger of fire.

5. Pass a fancy cord or ribbon under the angel's arms and cross the cord over the breast. Tie it behind the head, leaving a long loop for hanging the angel on a tree or in a window (Fig. 3).
6. Cut a face for the angel from a colored magazine illustration. Attach the face with rubber cement or glue.

CHRISTMAS TREE ANGEL

made from

TIN CANS, SILVER OR GOLD
PAPER ~ FACE CUT FROM A
MAGAZINE ~ FANCY CORD ~
RED NAIL POLISH AND
BIRTHDAY
CANDLE.

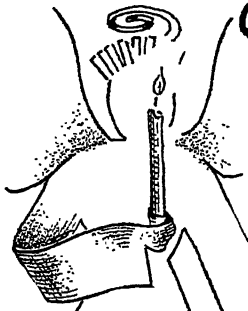

Fig. 2.



Fig. 3.
CROSSED CORD
FOR HANGING.

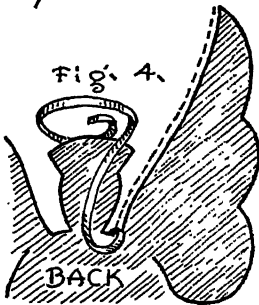

Fig. 4.

BACK

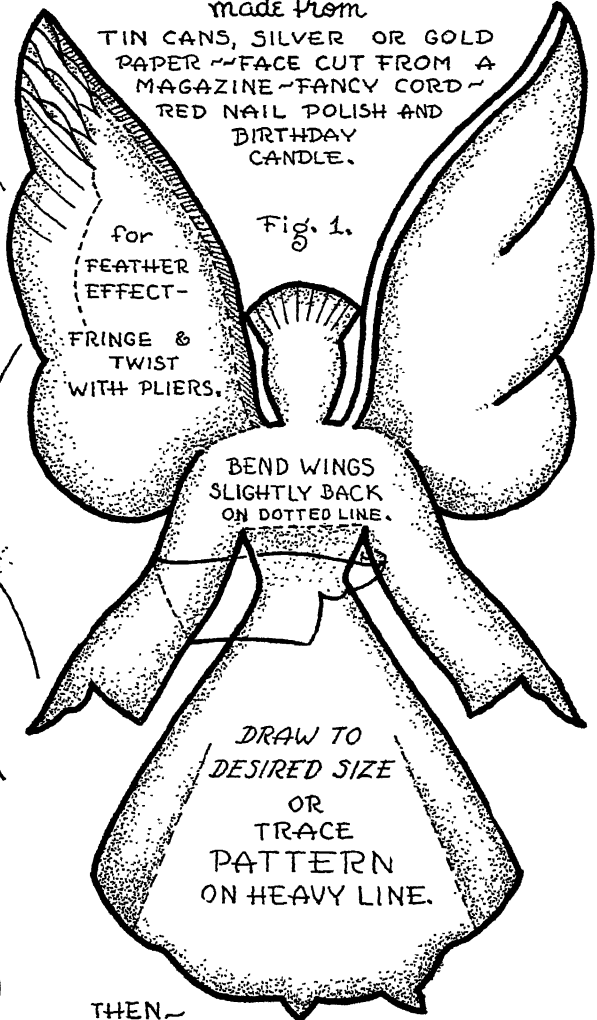

Fig. 1.

for
FEATHER
EFFECT-

FRINGE &
TWIST
WITH PLIERS.

BEND WINGS
SLIGHTLY BACK
ON DOTTED LINE.

DRAW TO
DESIRED SIZE
OR
TRACE
PATTERN
ON HEAVY LINE.

THEN ~

TRACE PATTERN ON CARDBOARD ~
CUT OUT AND TRACE AROUND EDGE
ON METAL WITH SHARP NAIL.
CUT ON ALL HEAVY LINES.

HOLIDAY CANDLESTICKS

MATERIALS

NOTE: This is an easy project to make for the summer camp. It will be a useful ornament for the dining table or bed table. It will make an interesting article for use in conjunction with the rustic whatnot.

Metal: The tops and bottoms of fruit or vegetable tins of any size desired can be used for the candlesticks in Plate 23. Tin cans with a gold lining are preferable.

Paints: Colored nail polish, enamels, or car touch-up paints.

Candles: The short ends of candles can be found in the home. They should harmonize in color with the candlesticks. Short pieces with drippings are more attractive. The candles can be dripped after they are placed in the candlestick.

TOOLS

Paper, pencil, compass, tin snips or heavy shears, and a metal file.

PROCEDURE

1. Using the salvaged tin can tops and bottoms as a guide, trace around the metal on paper. Then, with a compass and ruler, divide this circle for 6 or 8 petals as shown in Figures 2 and 4.
2. Using carbon paper, trace the design onto the unpainted surface.
3. The can lids selected may be used with or without color. The contrast of gold and silver, when finished, is most attractive. If desired, apply nail polish or enamel to either side before cutting.
4. With tin snips or heavy shears, cut the metal as illustrated.
5. File all edges smooth and bend the petals as shown. Note that all number one petals are bent down and number two petals are bent up.

Figure 1 shows the finished candlestick cut from the pattern in Figure 2. Bend the petals with a round pencil, or similar object, adjusting them as illustrated.

Figure 3 represents the finished article made from the pattern in

HOLIDAY CANDLESTICKS

made from

TIN-CAN TOPS, SCRAP ALUMINUM AND
COPPER—
& RED NAIL POLISH.

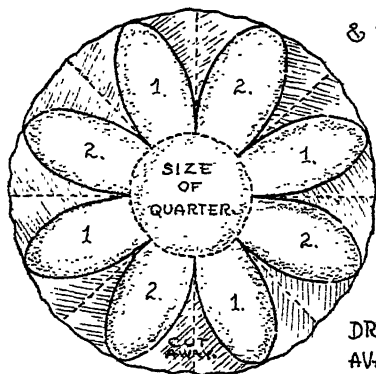
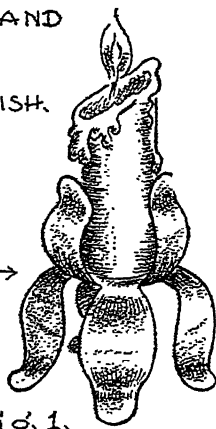

Fig. 2.

3" TO 8"
DIAMETER



DRAW TO FIT
AVAILABLE TIN *or* Fig. 1.
TRACE PATTERN
& OUTLINE ON METAL
WITH SHARP NAIL.

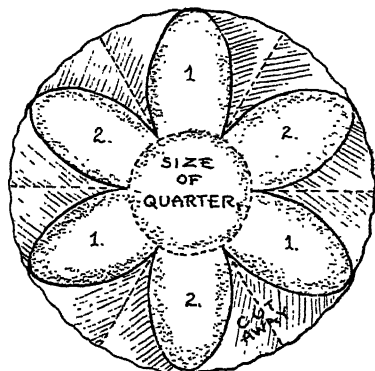

Fig. 4.

3" TO 4"
DIAMETER

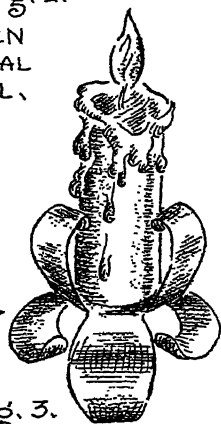

Fig. 3.

EASILY CUT WITH TIN
SNIPS OR HEAVY SHEARS.

Plate 23

Figure 4. The prongs and feet, which bend in the opposite direction, can be shaped with a round pencil.

6. Dripping of the candles might be done after placing them in the finished candlestick. Candles should harmonize in color with the color applied to the metal.

DARNING KIT FOR TRAVELING

MATERIALS

Metal: A 6 oz. tuna fish can and lid for the Kit in Plate 24.

Felt: Scraps of bright colored felt from a lady's discarded felt hat.

Yarns and Cotton: Colored yarns and a small amount of cotton.

Buttons or Beads: Buttons or beads to add sparkle.

Darning Cottons, Thimble, and Needles: A small set of darning cottons, thimble, and several needles for the kit.

TOOLS

Pencil, paper, and ruler for making patterns; pinking shears or large scissors; darning needle; and razor blade.

PROCEDURE

1. Draw the patterns (Figs. 3 and 4).
2. Clean the felt with cleaning fluid or with cool water and soap. Cut and dry the felt. See Section 4, "Felt and Plastic Cosmetic Kit," step 2.
3. Pin the patterns in Figures 3 and 4 to the felt and cut out. Use pinking shears for the circular pieces and a ruler and razor blade for the rectangular strips.
4. Sew the bottom lining to the bottom edge of the inside lining strip and place it in the tuna tin. The lining will show above the edge of the tin.
5. Sew the bottom piece to the outside covering as shown in Figures 1 and 2 and set the tin into it. Stitch the outside covering to the inside lining at the top (Fig. 2). Use colored yarns and stitch as shown in Figure 5. Use either style of stitching.
6. Cover the tin lid with the two circles of felt cut for it. Insert a tuft of cotton under the lid to serve as a needle cushion, and then finish stitching (Fig. 5).
7. Attach the cover by means of stitches (Fig. 1).
8. Sew a bead on a loop of colored yarn and fasten it to the cover. Hook the bead loop over a button at the side to keep the contents from spilling.

DARNING KIT FOR TRAVELING

made from
A TIN CAN -
FELT SCRAPS -
BRIGHT YARNS -
BUTTONS OR
BEADS.

TOOLS:
TUNA TIN -
SAVE THE
LID -
PINKING
SCISSORS -
NEEDLE -
PAPER AND
PENCIL AND
RULER.

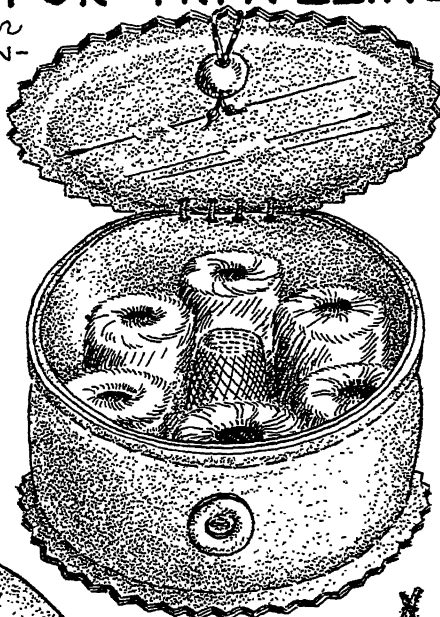

PATTERN
FOR OUTSIDE COVER, USE 11×2 "
FOR INSIDE LINING, USE $11 \times 1 \frac{1}{2}$ "

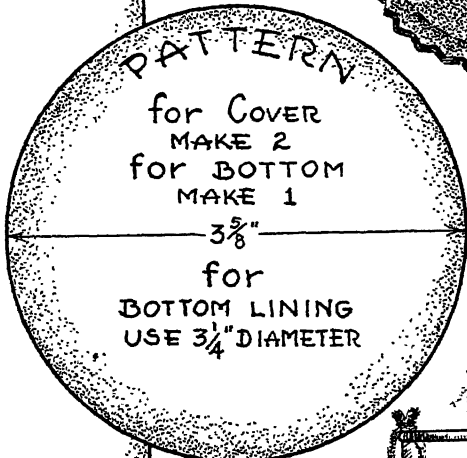

Fig. 3.

Fig. 1.



Fig. 5.

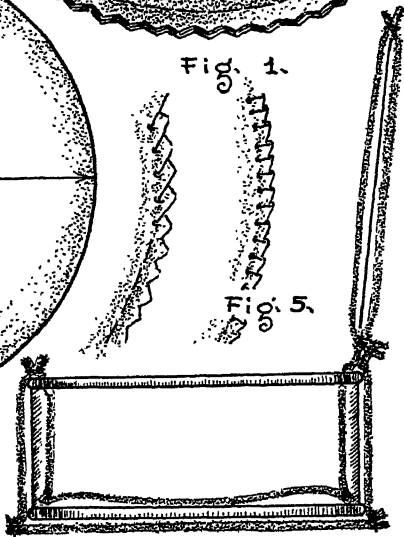

Fig. 2.

Fig. 4.

Plate 24

CHILDREN'S TOY DRUM

MATERIALS

Tin Cans: Can of a size suitable for the drum (Plate 25, Figs. 1 and 2).

Drumheads: Toy drumheads can be made from inner tubes. Rubber will give a variety of tones, depending upon how tight the material is stretched. It is stretched tight for higher tones and loose for the lower ones.

Birch Bark or Wallpaper: Cover the can with birchbark, if available, or wood-grained wallpaper. Both give an attractive appearance and eliminate the tinny look.

Lacing: Colored fish cord, leather bootlaces, or binder's twine.

Drumsticks: Old chair rungs or any straight, round sticks. Broken arrows can be used.

Additional Materials: Paper for patterns, sandpaper, glue, and clear shellac or varnish.

TOOLS

Pencil, a compass, paper clips, saw, turnkey can opener, heavy shears, and leather or paper punch.

PROCEDURE

1. Cut both ends from the tin can.
2. Place the can on a piece of paper and trace around it. With a compass, enlarge this circle about $1\frac{1}{2}$ to 3 in. in diameter (Fig. 4).
3. Cut the tire tube at the inner seam, flatten it, and trace the pattern onto the rubber with carbon paper or chalk. Make two heads. Cut the rubber with heavy shears or tin snips.
4. Fold the circular paper pattern into 6 or 8 parts and punch about $\frac{1}{2}$ in. from the edge. Unfold the pattern, lay it over the rubber drumheads, mark the holes on the rubber, and punch for lacing (Fig. 4).
5. Cut birchbark or wallpaper to cover the can with an overlapping pasting flap. Apply the paper to the can with glue or clear shellac.

CHILDREN'S TOY DRUM

made from
TIN CANS, BIRCHBARK
OR WALLPAPER, INNER-
TUBE FROM CAR TIRES &
LEATHER BOOT LACES.
DRUMSTICKS FROM BROKEN
ARROWS.

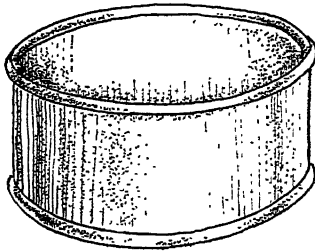
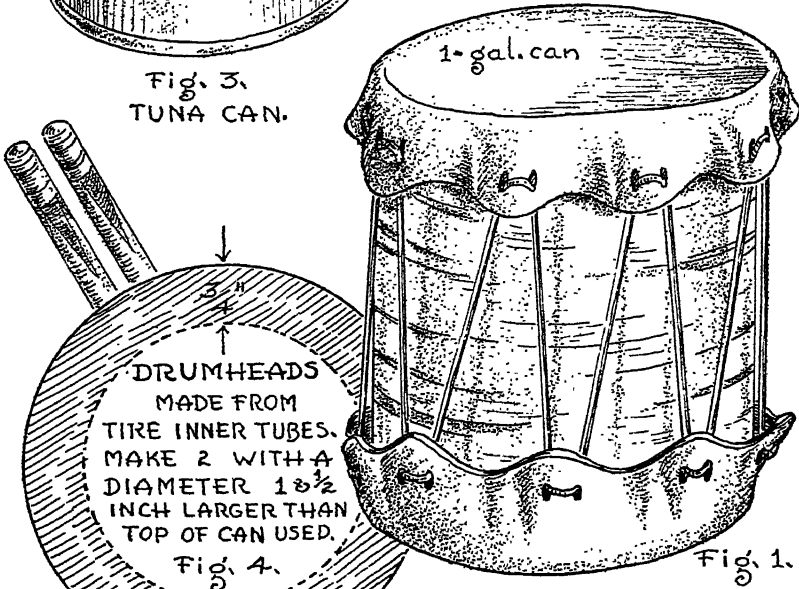

Fig. 3.
TUNA CAN.



DRUM MADE
FROM TUNA-FISH CAN
COVERED WITH PLASTIC
OR. COLORED LEATHER
MAKES XMAS-TREE ORNAMENT.

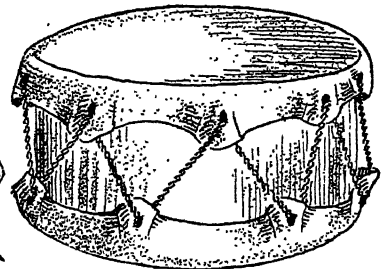

Fig. 2.

When dry, apply one or more coats of shellac or varnish over the paper or bark (Fig. 1).

6. Adjust the rubber drumheads to both ends of the can and keep them in place by inserting unfolded paper clips or bent wires into the holes. This will help keep the drumheads in position while lacing and stretching. When more than one drum is made, stretch some drumheads tighter than others for variation in tone. Lace with heavy, colored fish cord or leather bootlaces (Fig. 1).
7. Saw the drumsticks from straight tree branches with the bark removed, chair rungs, or broken archery arrows. Leave the color bands on the latter if there are any. Sand the ends of the sticks (Fig. 4).
NOTE: A tuna-fish can made with bright colored cloth or leather, instead of the rubber covering, will make an attractive Christmas tree ornament (Fig. 2).

ALUMINUM OR COPPER BUD VASE

MATERIALS

Metals: Scraps of aluminum or flashing copper can be salvaged from various sources for the vase in Plate 26.

Lozenge Bottles or Perfume Phials: Use a throat lozenge bottle or a perfume phial for this bud vase. Such bottles seem ready made for craftwork (Fig. 1).

Other Materials: Paper for patterns, steel wool, and clear lacquer or varnish.

TOOLS

Pencil, compass, tin snips, and metal file.

PROCEDURE

1. Make the pattern (Fig. 2). The base should be proportionate to the bottle or phial.
2. Lay out the metal with a sharp pointed instrument.
3. Cut the metal with tin snips or heavy shears, file the edges smooth, and polish both surfaces and all edges with steel wool. Polish with

ALUMINUM ^{or} COPPER BUD VASE

made from
SCRAP ALUMINUM OR COPPER.

TOOLS ~

TIN SNIPS - METAL FILE

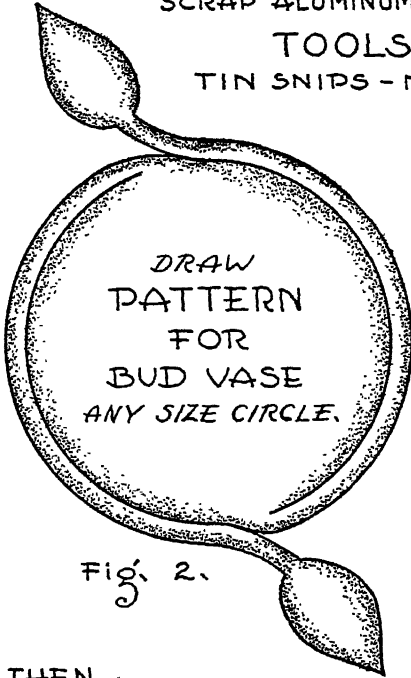

Fig. 2.

THEN ~
TRACE PATTERN, Fig. 2,
ON PAPER. POLISH THE
METAL WITH STEEL WOOL
AND TRACE PATTERN
ON METAL WITH CARBON
PAPER. ~ ~ CUT METAL
WITH TIN SNIPS AND FILE
EDGES SMOOTH. POLISH
AGAIN WITH STEEL WOOL,
THEN LACQUER. WIND THE
STEMS & LEAVES AROUND A
SMALL GLASS PHIAL OR BOTTLE.



Fig. 1.

steel wool in one direction only or a scratched appearance will result. Coat the metal with clear lacquer and let it dry.

4. Figure 1 illustrates the metal leaves and stems wound around the bottle in one direction only. Note that the ends of the leaves are bent slightly, adding a note of interest. Wind the stems as close together or as far apart as necessary for conformity with the size of the vase.
5. Glue felt to the bottom of the bud vase.

LETTER HOLDER

MATERIALS

Metals: Scrap aluminum or copper salvaged from the tinsmith's shop for the letter holder in Plate 27. Such metals are used for air ducts in a hot air furnace. Used aluminum saucepan lids are practical also.

Felt or Leather: Leather or felt cut from discarded purses and hats can be used on the bottom of the letter holder.

Additional Materials: Paper for patterns, carbon paper, steel wool, and clear lacquer or spar varnish.

TOOLS

Pencil, ruler, compass, tin snips or heavy shears, metal file, and machinist's hammer.

PROCEDURE

1. Having obtained metal of the desired size, use paper, pencil, ruler, and compass to draw the pattern. The pattern can be made any size desired (Fig. 1). A square holder is pictured in Figure 3.
2. Trace the pattern onto the metal with carbon paper, or cut the paper pattern and trace it on the metal with the point of a compass.
3. Cut the metal on the outline with tin snips or heavy shears. Then using the metal file, smooth the edges. Rubbing with steel wool in one direction only, polish the metal to a soft luster.

LETTER HOLDER

MADE FROM
SCRAP ALUMINUM USED IN
AIR DUCTS OF NEW HOMES-
OR SCRAP COPPER FLASHING
USED IN ROOFING. PICK UP
AROUND NEW BUILDINGS BEING
ERECTED-- OR SEE YOUR
FURNACE MAN.

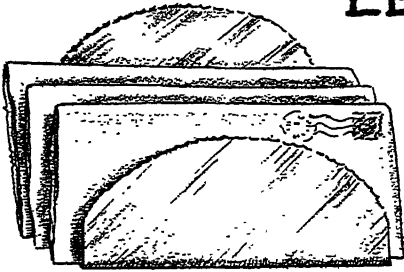

Fig. 2.

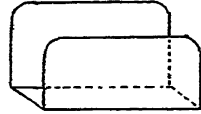

Fig. 3 SHOWS
SQUARE INSTEAD
OF CIRCLE.

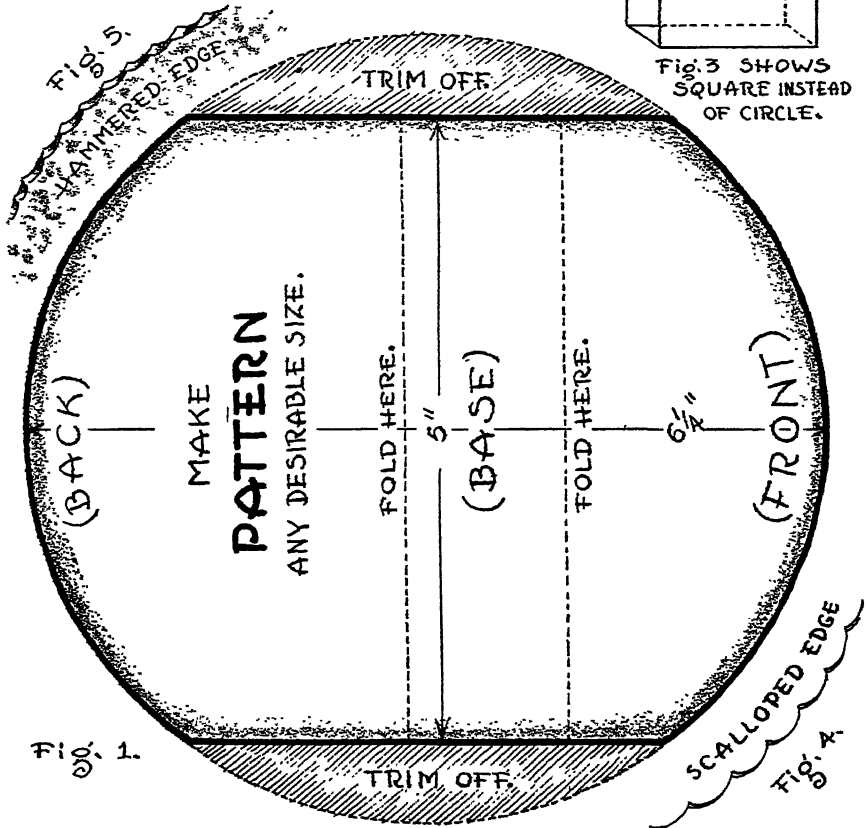

Plate 27

4. Set the metal on edge on a firm surface and hammer the edge as illustrated in Figure 5. If preferred, a scalloped edge can be obtained with the metal file. Make grooves with the corner of the file and then round the spaces between grooves as shown in Figure 4.
5. If desired, make a design or monogram on the letter holder before folding. Use a large nail with a flattened point, and a hammer. Designs first should be developed on the paper pattern and traced on the metal with carbon paper.
6. Bend the metal over the edge of a worktable or piece of wood held in a vise.
7. Cut leather or felt from a discarded purse or hat and glue it to the base of the letter holder. If a high polish is obtained on the bottom, you may prefer not to use a protective material.
8. Hold the metal with a soft clean cloth or paper towel to eliminate finger marks, give the holder one last gentle polishing with steel wool. Then brush off article and apply one or more coats of clear lacquer or spar varnish.

ASH TRAY OR PIN TRAY

MATERIALS

Metals: The copper half-tone plates mounted on blocks and used in printing the school yearbook will make a beautiful hammered tray (Plate 28). Scraps of heavier copper flashing or air-duct aluminum can be salvaged from the scrap pile at the tinsmith's shop.

Hammering Board or Bag: A bag for hammering deep metal trays or bowls can be made from two old boot tops or scraps of cowhide sewed together and filled with fine sand (Fig. 4). Shallow trays can be formed on a flat, hardwood board with a strip of the same wood nailed to the edge (Fig. 2). Enlarge the pattern in Figure 1 for the tray in Figure 3.

Other Materials: Paper for patterns, steel wool, ten cents worth of liver of sulphur to color the metal, and clear lacquer or varnish.

TOOLS

Pencil, compass for patternmaking, heavy copper, small tin snips for cutting lighter metal, metal file, and ball-peen hammer.

ASH TRAY OR PIN TRAY

made from
SCRAP COPPER OR ALUMINUM

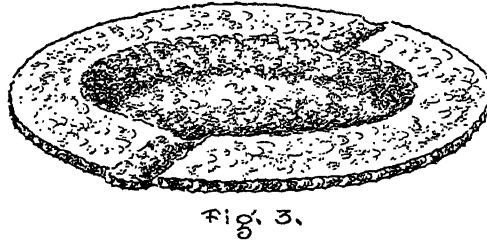
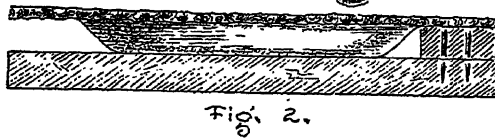
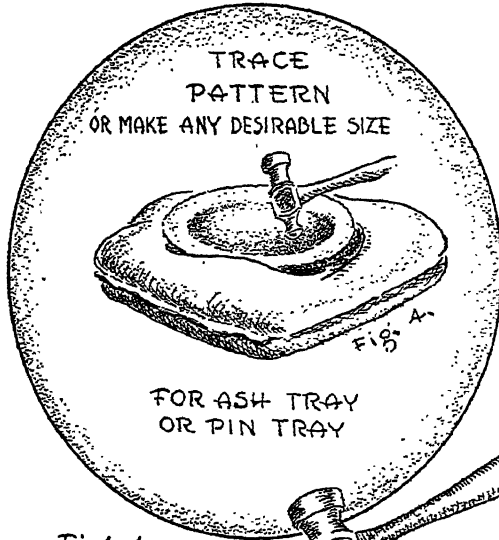

Plate 28

PROCEDURE

1. Make the pattern.
2. Lay out the metal.
3. Cut the metal to size. File the edge and both surfaces smooth.
4. Polish the metal brightly with steel wool before hammering or coloring.
5. To oxidize copper, dissolve liver of sulphur crystals in water, and apply the solution to the polished metal, before hammering, with a soft cloth. When the desired color appears, submerge the metal in cool water to stop the coloring action.
6. For a deep tray, cut a hammering bag either square or round. Use old boot tops, cowhide, or heavy canvas. A good working bag is about the size of a dinner plate. Sew leather together tightly with heavy linen thread or carpet warp. Fill the bag with fine sand before taking the last stitches. Metal will stretch more on a soft bag and will make a deeper bowl (Fig. 4). Form the tray with a machinist's hammer, heating the metal at intervals over a flame to keep it from cracking and to insure stretching.
7. Use the frame illustrated in Figure 2 for a shallower tray. The metal need not be heated for this process. The strip of wood nailed to the edge of the board is to facilitate hammering the bowl part of the tray, leaving the rim flat. Note the position of the hammer in shaping the tray depth. If the rim or the bottom of the tray warps from hammering, turn the metal upside down on the board and flatten it with the flat end of the hammer.
8. Apply a coat of clear lacquer or varnish to the pin tray. The ash tray requires no additional finish.

NAPKIN RING OR BRACELET

MATERIALS

Metals: Aluminum or copper scraps can be used for the articles in Plate 29.

Other Materials: Paper for patterns, carbon paper, steel wool, and clear lacquer or spar varnish.

NAPKIN RING OR BRACELET

made from
COPPER OR ALUMINUM

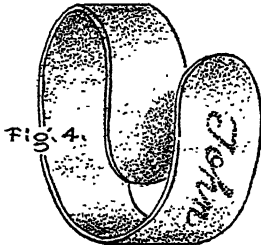
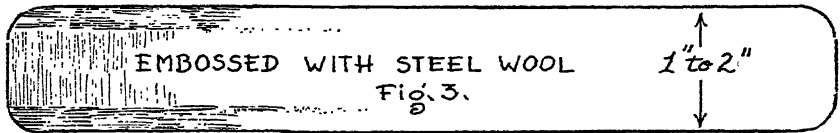
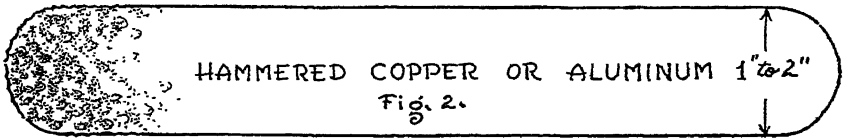
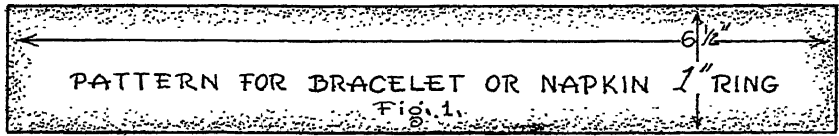

"CURL" NAPKIN RING

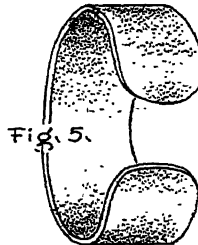

"COLLAR"
BRACELET

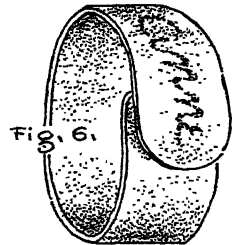

"BELT" NAPKIN RING

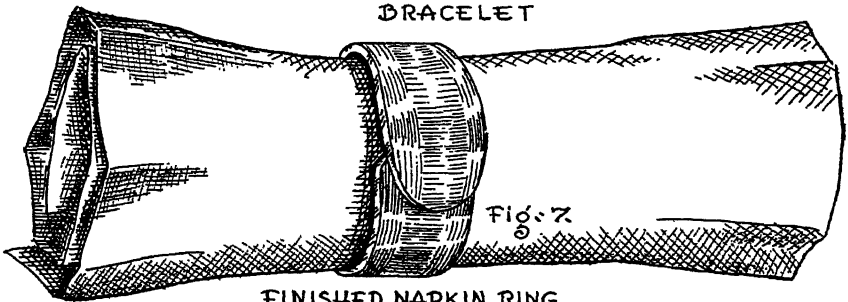

TOOLS

Pencil, ruler, tin snips or heavy shears, metal file, machinist's hammer, and electric engraving tool.

PROCEDURE

1. Draw the pattern, using the dimensions suggested in Figures 1, 2, or 3. Transfer the pattern to the metal with carbon paper, or cut out the paper pattern and trace around it with a sharp tool directly onto the metal.
2. With tin snips or heavy shears, cut the metal bracelet or napkin ring. Round the corners and smooth the edges with a file.
3. For the finish shown in Figure 3, polish the metal crosswise with the steel wool. Then cover all but a narrow border along one side with heavy paper or lightweight cardboard, and polish with steel wool. Make a corresponding border on the other edge of the metal.
4. Clean the metal with a soft cloth, and apply one or more coats of clear lacquer or spar varnish.
5. Bend the bracelet or napkin ring around an old chair leg or broomstick.

NOTE: 1. If an electric engraving tool is available, a name can be printed on the metal. 2. For the peened finish (Fig. 2), polish the metal with steel wool; then lay it on a hardwood surface and hammer it with a ball-peen hammer.

BRACELET, MONEY CLIP, AND TIE CLASP

MATERIALS

Metals: Scrap aluminum or copper for the articles in Plate 30 is usually free for the asking.

Felt, Nuts, Pine Cones, and Beads: Small felt scraps cut from a lady's discarded felt hat, acorns, hazel nuts, pine cones, colored glass beads, or wooden beads.

Additional Materials: Paper, carbon paper, steel wool, clear lacquer, or spar varnish.

BRACELET-MONEY CLIP-TIE CLASP

FOR BOYS & GIRLS
made from
SCRAP COPPER & ALUMINUM

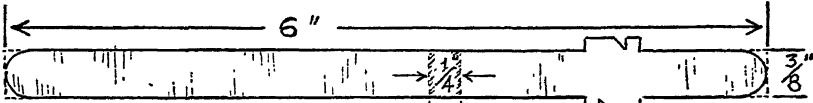

PATTERN FOR TIE CLASP
Fig. 1.

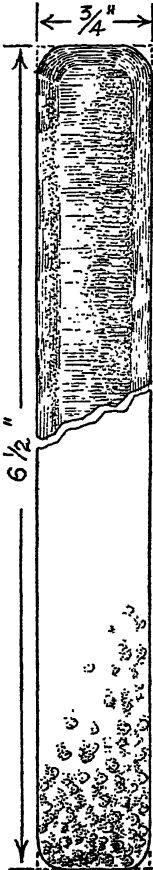

Fig. 5. - HAMMERED COPPER OR ALUMINUM BRACELET WITH STEEL-WOOL FINISH.



Fig. 6.
ACORN & FELT
LABEL PIN.



Fig. 2.

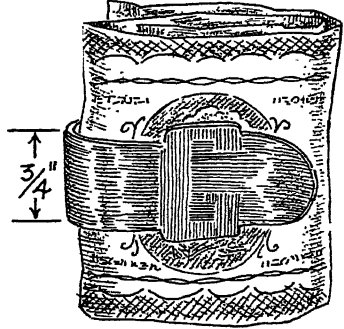

Fig. 4.
MONEY CLIP.

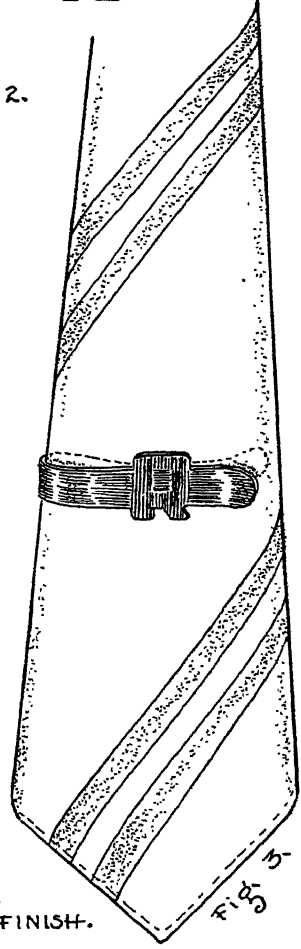

Fig. 3.

• Plate 30

TOOLS

Pencil for patterns, ruler, tin snips or heavy shears, metal file, and ball-peen hammer.

PROCEDURE

Tie Clasp

1. Make the pattern (Fig. 1), using a block letter for the monogram (Fig. 3), and lay it out on scrap copper, aluminum, sterling silver, or pewter.
2. Cut out with a tin snips or heavy scissors, and file the edges.
3. Polish with steel wool in one direction only. Cover the entire clasp, except the monogram, with heavy paper or cardboard and polish the monogram in the opposite direction.
4. Apply one or more coats of clear lacquer or spar varnish.
5. Bend the tie clasp around a pencil (Fig. 2).

Money Clip

Make the pattern for the money clip enlarging it as shown in Figure 4. Complete it according to the above procedure.

Lapel Pin

Make the lapel pin shown in Figure 6 from scrap felt. Cut interesting leaves in colors to harmonize with a specific costume. Burn holes in acorns or hazel nuts with a red hot needle and sew them to the leaves. Attach a small safety pin to the back of the ornament in the same manner. An attractive ornament to be worn at Christmas time can be made with green felt cut to represent holly leaves with small pine cones attached. Red glass or wooden beads might be used to represent holly berries.

Bracelet

1. Make the pattern as illustrated in Figure 5 and lay out the metal for the bracelet.
2. Cut out and file the edges.
3. For the finish shown in the upper part of Figure 5, use steel wool. Polish the entire bracelet crosswise only. Then cover the entire bracelet except a border along one side and one end with a heavy

paper or cardboard, and steel wool a border lengthwise and across one end. Repeat the process on the opposite side and end of the bracelet and brush off the dust particles.

If a hammered effect is desired, polish the metal with steel wool; then lay it on a hardwood surface and peen it with a ball-peen hammer (Fig. 5, lower half).

4. Apply one or more coats of clear lacquer or spar varnish.
5. Bend the metal to fit the arm (page 76, step 5).

SECTION 4 — FELT

FELT AND PLASTIC COSMETIC KIT

MATERIALS

Felt: One or two lightweight, colored felt hats — enough for both sides and the flap of the cosmetic kit (Plate 31, Fig. 1).

Plastic Cloth: The same amount as the felt needed. Use plastic scraps from a shower curtain, bathroom or kitchen curtains, or plastic apron scraps.

Threads: Embroidery silk, carpet warp, or colored yarn from the sewing basket. Any heavy thread or string, the same color as the felt or a harmonizing color will add to the effect.

Beads: Beads are optional. Small glass beads placed on the colored thread between stitches will provide additional decoration.

Buttons and Bows: Large decorative buttons may be used to fasten the flap of the kit. A bright-colored shell may be used in place of a button. If a bow is desired on the flap, use a harmonizing ribbon or bow of self-colored felt (made of the same felt as the kit) with a snap fastener instead of the button and button hole.

Other Decorations: Colored sequins can be used in place of beads. Monograms, flowers, birds, etc., may be sewn on the flap of the kit to personalize it (Fig. 4).

Additional Materials: Cool water in a pan for stretching felt, and paper for making patterns.

TOOLS

A board, plenty of pins for stretching the felt, pencil, ruler, pinking shears for edging felt if desired, a large darning needle for stitching, and razor blade.

PROCEDURE

1. Make two patterns like that shown in Figure 3, one with the flap and one without it.
2. If a discarded felt hat is used, cut as shown in Figure 1 and wash with

FELT & PLASTIC COSMETIC KIT

made from

LADIES' DISCARDED FELT HATS,
PLASTIC SCRAPS FROM CURTAINS,
BEADS, YARNS, SHELLS & BUTTONS.

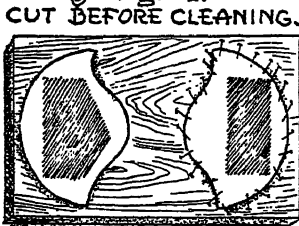

Fig. 2.

TO FLATTEN THE FELT IN AN OLD HAT SOAK IN COOL WATER AND WASH WITH A MILD SOAP. RINSE THOROUGHLY IN COOL WATER, FLATTEN AND PIN TO BOARD TO DRY.

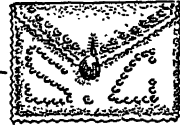

Fig. 4.

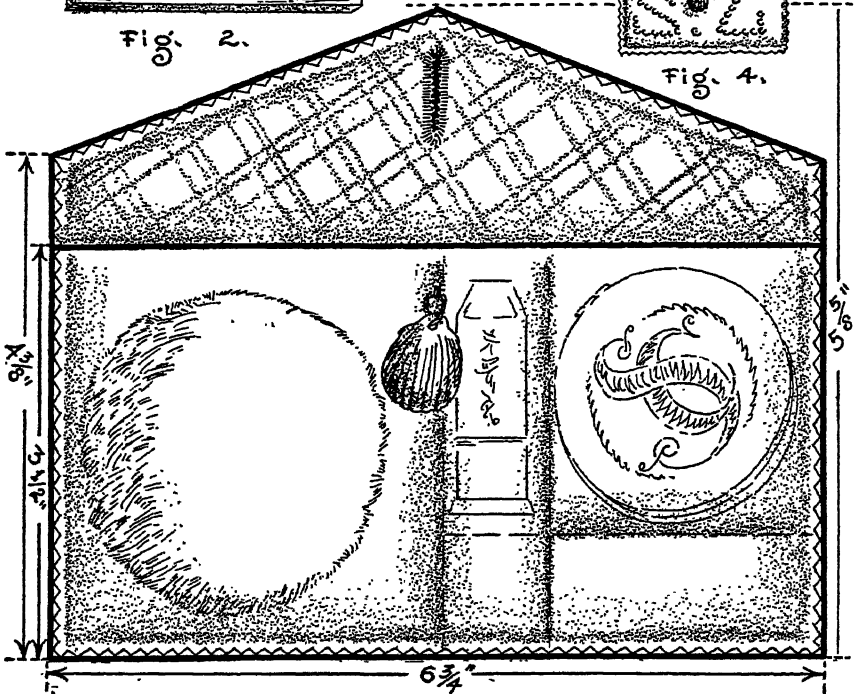

FIG. 3. - SEE ALSO PROJECT "PULLMAN SLIPPERS."

Plate 31

- soap in cool water. Stretch the felt as shown in Figure 2 and let it dry thoroughly.
3. When the felt is dry, lay it over the plastic and pin the patterns to both the felt and plastic. Then cut around the pattern with either plain or pinking shears.
 4. Remove the patterns and add decorations on the flap or front of the kit, with embroidery, beads, or sequins, sewing through the felt only (Fig. 4).
 5. When the decorations have been applied, again pin each piece of plastic lining to its matching piece of felt, and pin them all together with the plastic pieces, sandwich-like, between the felt pieces.
 6. Stitch the kit together as shown in Figure 3. Use beads or sequins as desired and choose either means of securing the flap as indicated under the heading Buttons and Bows above.
 7. Note the stitched divisions for compact, lipstick, and powder puff (Fig. 3). If the kit is desired for a traveling kit for folding bedroom slippers, for washcloth and soap, or for a purse, the division stitching may be omitted (see Section 4, "Pullman Slippers and Case").

POTTED CACTUS PINCUSHION FOR THE FLOWER STAND

MATERIALS

Felt: Green felt for the base of the cactus and bright-colored felt scraps for the blossoms or buds (Plate 32).

Cotton: A sufficient amount to stuff the cactus.

Brace or Stem: A small stick, pencil, or broken penholder to insert as a spine or stem for the cactus, giving it firmness and holding it erect in the flowerpot.

Flowerpot: A tiny flowerpot, mushroom tin, or salmon can painted with nail polish or decorated with fancy paper in which to "plant" the cactus.

Soil for the Flowerpot: Plastic wood, plaster of Paris, modeling

CACTUS PIN CUSHION

MADE FROM
FELT SCRAPS.

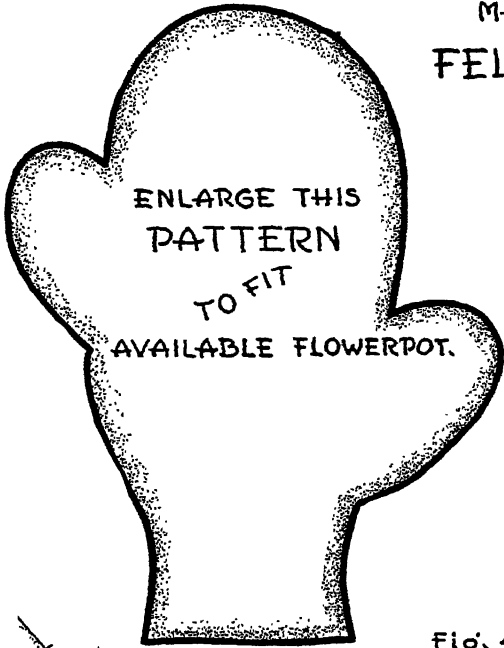

Fig. 1.

OVERCAST
STITCHING
for
SMOOTH EDGE.



Fig. 3.



RUNNING STITCH
for
PINKED EDGE.

Fig. 2.

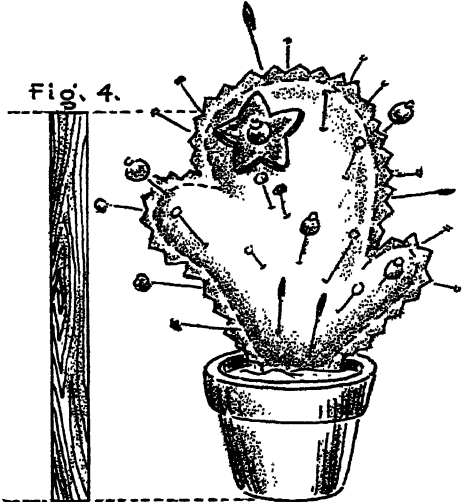

Fig. 4.

FINISHED CACTUS, Fig. 5.

Plate 32

clay, or plain yellow clay will hold the cactus firmly in the pot when set and dry.

Thread: Embroidery thread, colored twine, or carpet warp for stitching around the edge of the cactus. This will not only hold the two sides together for stuffing but will be decorative and will give an effect of thorns on the edge.

Added Decorations: Bright-colored beads from broken or discarded necklaces, or sequins from ladies' old purses, scarves, or dresses will suggest buds or blossoms. Several "buds" may be used if desired. Bright glass-head pins.

TOOLS

Scissors, pinking shears if available, large needle, and pins.

PROCEDURE

NOTE: Set the cactus pincushion among the potted plants in the home. It will blend in with the other plants, yet be handy when pins or needles are needed. It will also brighten up the classroom window when used in lieu of potted plants or with some of the growing vines in the school.

1. Make the pattern the size shown in Figure 1 or enlarge it.
2. Pin the pattern to a double thickness of green felt and cut out both thicknesses at the same time with either pinking shears or plain scissors.
3. Using a large needle and either embroidery silk or colored twine, stitch the two pieces of felt together, leaving the bottom open for the padding or stuffing. If pinking shears have been used for the cactus edge, a running stitch just inside the thorny edge will be sufficient (Fig. 2). However, if plain scissors have been used, the thorny edge effect will be obtained by overcast, diagonal stitches evenly spaced (Fig. 3).
4. Cut a stick, pencil, or penholder just a little shorter than the entire measurement from the tip of the cactus to the bottom of the flowerpot (Fig. 4). Wrap cotton tight around the stick and insert it into the opening of the cactus. Then add more stuffing by inserting cotton with a stick or pencil.
5. Now fill the flowerpot to about one fourth from the top, with either plastic wood, plaster of Paris, modeling clay (the hardening

kind), or plain yellow clay for "soil." Insert the cactus stem into the material while soft so that the bottom edge of the cactus is slightly covered.

6. When dry, paint the "soil" with nail polish or water color.
7. From the bits of bright-colored felt, cut a small flower. Cut a center for the flower from either black or yellow felt and pin them to the cactus with a pin with a bright-colored bead on it. Pin the flower close to the edge of the cactus or near the top. More than one blossom may be used if desired.
8. If desired, add bright-colored beads or sequins by running a pin through them and pinning them to the cactus for small buds.
9. For a finishing touch, insert the pins and needles which have been collected for the cushion along the edge of the cactus and scattered about the entire surface. This also gives a prickly or thorny effect (Fig. 5).

FELT PUMPKIN TEA COZY

MATERIALS

Felt: Salvage material from discarded felt hats—a sufficient amount to make both sides of the pumpkin pattern (Plate 33). Any warm color will do. Procure enough dark-brown or dark-green felt for the stem and any shade of green felt for the four leaf pieces.

Threads and Added Decorations: Embroidery silk, cotton thread, yarn or carpet warp, and small Indian beads of one color or assorted colors.

Additional Materials: Cleaning fluid or soap and clear water.

TOOLS

Large and small needles, thimble, plain scissors or pinking shears, and pins.

PROCEDURE

1. Draw and enlarge on paper, the outline of the body of the pumpkin pattern (Fig. 2). Figure 4 suggests how tissue paper can be molded

over any round teapot and then the pattern cut and used for tracing.

2. Remove all decorations and inside linings. Clean the felt hat, if necessary, with cleaning fluid or soap and cool water. Cut the felt hat as shown in Figure 1. The crown of the felt hat will be found preshaped for this purpose.
3. Pin the traced pumpkin pattern to each half of the hat, one half at a time, and cut with plain scissors.
4. Mold a leaf pattern, as suggested in Figure 2, over the spout and handle of the pot, cut out the pattern, pin it to four thicknesses of felt (two at a time), and cut out with either plain scissors or pinking shears. The leaf pattern is shown in Figure 5. The edge of the leaf adjoining the body of the pumpkin is shown by a dotted line inside the edge of the pumpkin.
5. Make a pattern for the stem (Fig. 3), and cut out the stem.
6. First sew in the running stitches on the face of the pumpkin. These denote form. Also blanket stitch across the tops of the pumpkin halves at the base of the stem.
Sew in the running stitches, or veining, in all four leaf halves. Pin the leaf halves together and stitch the pieces together according to the illustration.

Note the types of stitching used on the various parts of the pumpkin and leaves before deciding which is preferred. The illustration shows that the two halves of the pumpkin are left open at the bottom so that the tea cozy can be placed over the teapot.

FELT PUMPKIN TEA COZY

KEEPS THE TEAPOT WARM.
MAKE PATTERN TO FIT
ANY TEAPOT.

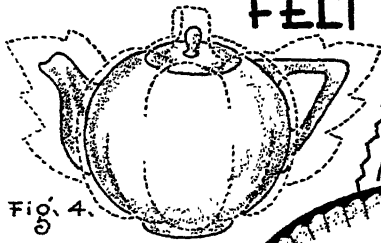

Fig. 4.

LEAVE 2 HALVES
OPEN FROM THIS
POINT TO POINT X
OPPOSITE.

(MAKE TWO)
PUMPKIN PATTERN.

Fig. 2.

MAKE PATTERN BY
MOLDING TISSUE PAPER
OVER ANY ROUND "T"-POT.

(MAKE ONE)
STEM PATTERN.

Fig. 3.

(MAKE FOUR)
LEAF PATTERN.

Fig. 5.

LEAVE THE
TWO HALVES
OPEN FROM THIS
POINT TO THE SAME
POINT ON THE OPPOSITE
LEAF.

Fig. 1.

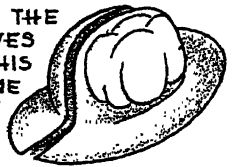

Plate 33

HOT-DISH HOLDER OR TABLE PAD

MATERIALS

NOTE: Various items can be made of felt strips, such as hot-dish holders, table pads, pincushions, chair and davenport sets, pillows, or scatter rugs.

Felt: Two or more men's or women's felt hats that harmonize in color will serve for the projects in Plate 34.

Threads: Colored yarns or embroidery threads.

Cotton: Quilting cotton for stuffing if the article is to be used as a pincushion.

Cushion: A feather or kapok cushion if the article is to be made into a sofa cushion.

Added Decorations: Beads, buttons, felt or ribbon bows or pompons of colored yarn.

TOOLS

Two pieces of composition board or plywood, the same size as the finished project is to be, plain scissors, pins or thumbtacks, and a pan for cleaning and soaking the felt.

PROCEDURE

1. Remove the decorations and linings from the hats. Then clean the felt hats with cleaning fluid or soap and cool water. Allow the material to dry thoroughly.
2. With plain scissors, begin at the edge of the hat brim and gradually cut along the edge until the felt strip is about $\frac{1}{2}$ in. wide or a little less. Continue cutting until the center of the crown is reached. Repeat this process on each hat to be used, although the width of the felt strip might vary with different colors (Fig. 1).
3. When all hats have been cut into strips, soak them thoroughly in clean cool water. Then pull the strips through tightly pressed fingers to remove excess water. Do not wad or squeeze the strips, because the felt will be creased.
4. Wind the strips of one color around the width of a board which

HOT-DISH HOLDER & PAD

made from

WOMEN'S DISCARDED
FELT HATS



TOOLS:

SCISSORS, A PAN OF
COOL WATER, PINS &
A STRETCHING BOARD.

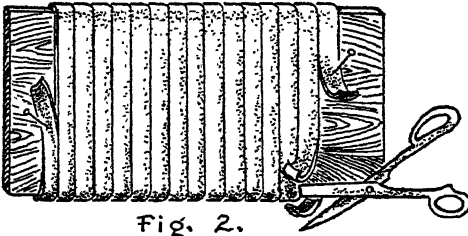

Fig. 2.

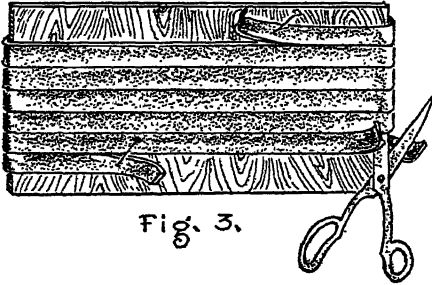

Fig. 3.

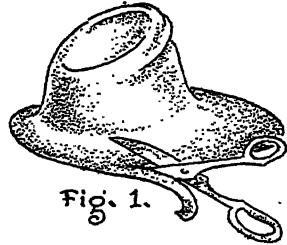

Fig. 1.

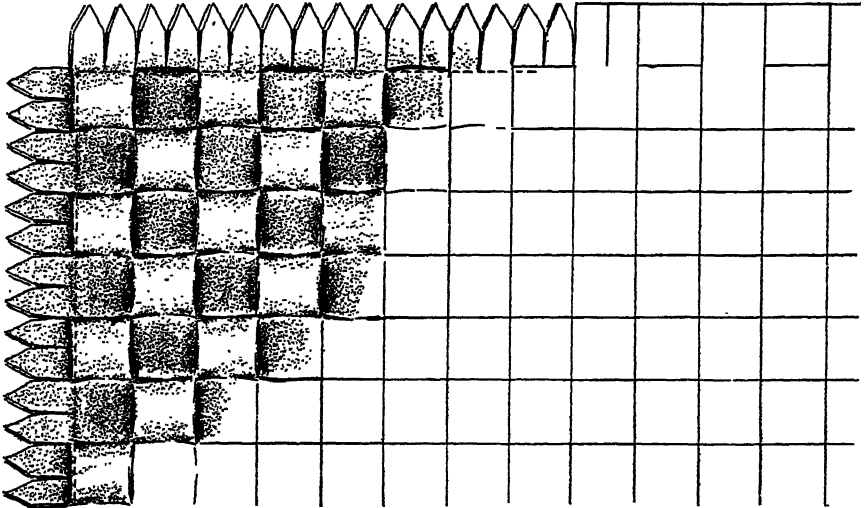

Fig. 4.

Plate 34

has been cut to the exact size of the object to be made (Fig. 2). Secure the ends to the board with pins or thumbtacks and let the strips dry.

5. Apply felt strips of another color to another board of the same size, winding it around the length of the board (Fig. 3). Use as many boards as there are colors to be used. Secure the ends to the board with pins or thumbtacks and let the strips dry.
6. After the felt strips have dried, using either plain scissors or pinking shears, cut them from the boards as shown in Figures 2 and 3.
7. Lay out the strips of felt in alternating colors, to the size of the object to be made. Weave them together as shown in Figure 4. Use pins to hold the weaving secure until finished, then stitch by hand around the edges as shown in Figure 4. Use silk floss, colored yarns, or carpet warp. Sew by machine if preferred.

FELT HANDBAG

MATERIALS

Felt Hats: Both women's and men's discarded felt hats (Plate 35). Bright-colored felt hats make gay bags for informal use and for use by children.

Drawstrings: A drawstring for closing the bag may be made from bootlaces, crocheted yarn, drapery tieback cords, or heavy, colored fishline.

Lacing: If lacing is desired as pictured in Figure 4, the same material as used for drawstrings will serve the purpose, or some harmonizing material will do, such as fine strips of felt cut from another color of this material.

Sequins and Scatter Pins: Sequins can be salvaged from discarded dresses or scarves. They can also be punched from the tops and bottoms of fruit or vegetable tin cans of plain silvered tin, coated with gold lacquer. First, with a very small nail and hammer, a number of small holes are punched for sewing, near the edge of the metal; then with a heavy paper punch, the sequins are punched out

HANDBAG

made from
LADIES' AND MEN'S
OLD FELT HATS.



BEST TYPE
LADY'S HAT.

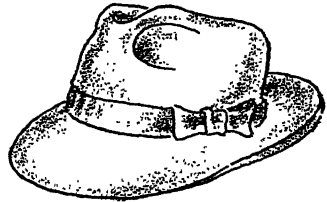

MAN'S HAT.



Fig. 3.

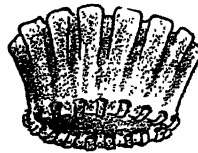

Fig. 4.

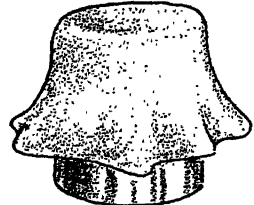

Fig. 1.

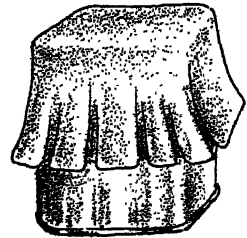

Fig. 2.



Fig. 5.

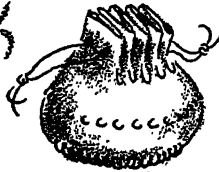
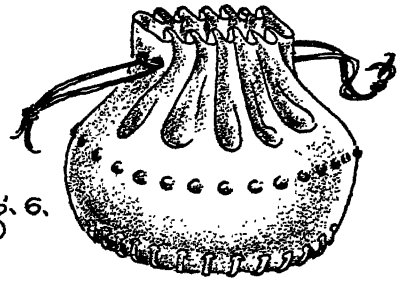

Fig. 7.

Fig. 6.



around the small nail holes. Colored car touch-up enamel or nail polish may be applied to the metal before punching. As added adornment, attach harmonizing lapel or scatter pins to the sides of the bag. Bright beads also can be attached to the ends of the drawstrings (Fig. 6).

Cleaning Materials: Cleaning fluid or soap and clear water.

TOOLS

Plain or pinking shears; heavy needle; self-colored cotton threads; heavy paper punch; and a gallon fruit can, a gallon antifreeze can, or a two quart fruit tin for stretching and molding the bag.

PROCEDURE

1. Remove all ornaments, bands, etc., from the felt hat. Clean if necessary with cleaning fluid or soap and cool water.
2. Soak the hat and brush both sides while wet. Then determine whether the inside or outside is to be used.
3. Place the felt hat over a can suited to the size and shape of the bag desired (Figs. 1 and 2). With a downward movement, slowly press the water from the felt, at the same time molding the felt to the form underneath. Begin at the center of the crown and stretch gently. Repeat until all excess water has been removed.
4. Using the fingers, press 6 or 8 pleats on both sides of the bag (Fig. 2). Crease the pleats upward about halfway. Remove the felt from the can when dry, and brush it gently.
5. Punch holes for the drawstring and for lacing at the bottom of the bag (Figs. 3 and 4).
6. Attach all decorations and lace in the drawstrings as illustrated in Figures 5 and 6.
7. Make a bag lining. Insert it into the handbag and stitch it to the bag at the top.

FELT AND FUR EAR MUFFS FOR GIRLS

MATERIALS

Felt: Colored felt for the base of the ear muffs—enough to make the two pieces according to the patterns in Plate 36, Figures 1 and 2.

Fur: Short-haired fur of a color that harmonizes with the felt—enough to make two pieces the size of the fur pattern (Fig. 2). Fur often can be salvaged from the collars and cuffs of women's coats.

Ribbon: At least one yard of ribbon or felt of the same color as the felt to be used for the ear muffs, or of a harmonizing color. This will serve as a headband and ties (Fig. 3).

Thread: Self-colored or harmonizing embroidery thread.

Added Decorations (Optional): Beads or sequins, or both. Small beads such as Indians use for their beadwork, or pearls, both large and small sizes. Beads of the Indian type can be salvaged from discarded handbags or from old dresses. Use pearls from a broken necklace.

TOOLS

Scissors, pinking shears if available, needle for the embroidery thread, thimble, and razor blade.

PROCEDURE

1. Draw the felt pattern to any desired size. If desired, instead of the circular pattern (Fig. 1), make one the shape of a child's mitten or animal. Cut out the pattern and pin it to a double thickness of colored felt. Cut around the pattern with pinking shears or plain scissors.
2. Cut out the fur pattern and trace it onto the skin side of the fur. Cut each piece of fur separately, laying the hair back away from the cutting edge toward the center of the circle to avoid clipping the hair ends.
3. As shown in Figure 1, with a razor blade make two slits in each piece of felt just a bit wider than the ribbon to be used.

FELT & FUR EAR MUFFS FOR GIRLS

MADE FROM SCRAP FUR AND FELT.

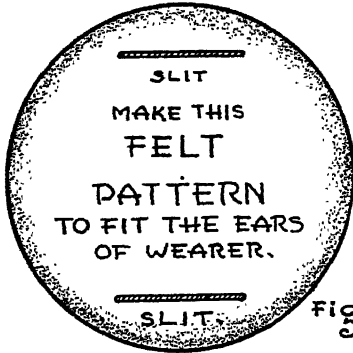

Fig. 1.

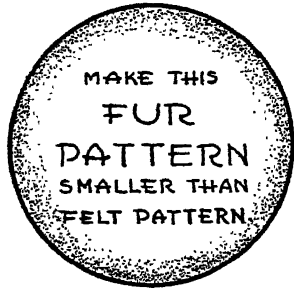

Fig. 2.

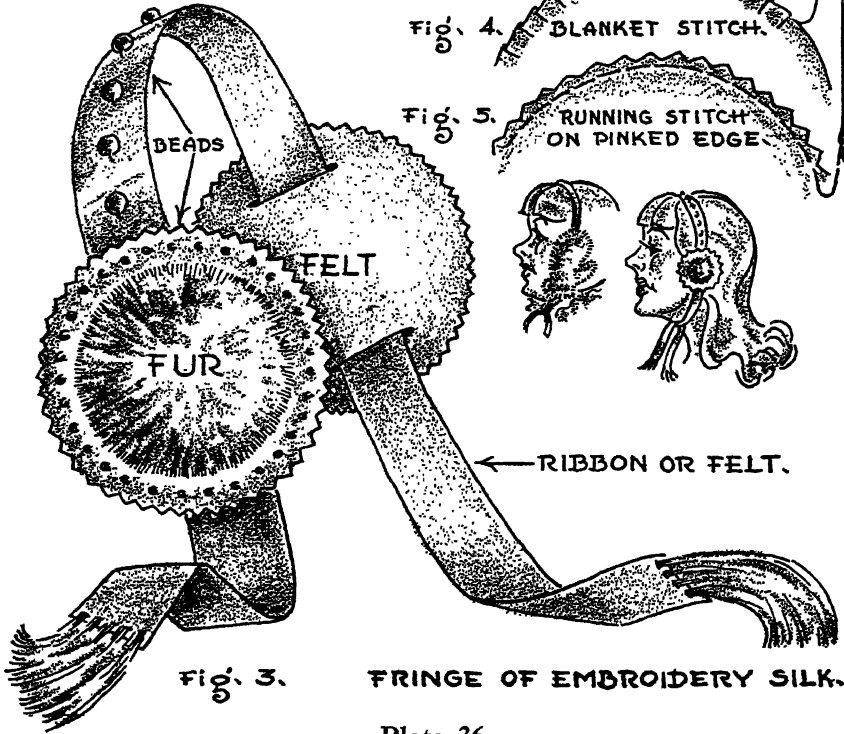

Fig. 3.

FRINGE OF EMBROIDERY SILK.



Fig. 4.



Fig. 5.



← RIBBON OR FELT.

4. Using thread the color of the fur, stitch the fur to the felt. Then with embroidery thread of a harmonizing color, decorate the edge of the felt as shown in Figures 4 and 5.
5. Run the ribbon through the slits as shown in Figure 3 and adjust the ear muffs to the head. Stitch the ear muffs in place on the ribbon. A fringe of embroidery silk will make an interesting tassel on the ribbon ends (Fig. 3).
6. As added decoration, beads or sequins may be sewn on the border of the felt to frame the fur (Fig. 3).

CHILD'S SWISS BONNET

MATERIALS

Felt: Secure a sufficient supply of felt from old felt hats (Plate 37, Fig. 8). The back and brim of the bonnet (Figs. 1 and 3) need not be of the same color. Also obtain a strip of felt for a bow if the bonnet in Figure 6 is chosen. Several scraps of bright-colored felt are needed for the floral decorations in Figure 4.

Ribbons: The bonnet in Figure 4 requires two ribbon ties about 10 in. long attached at the base. The one in Figure 5 has a ribbon long enough to extend across the crown, a bow at the top, and tie ends about 10 in. long. Use silk ribbon or felt strips for the ties shown in Figure 6.

Hatpin: Eliminate ribbons if a hatpin is preferred. Use a colorful corsage pin or a large darning needle with a bright bead or pearl glued to the eye end. Also a corsage pin with felt flowers sewed over the head is decorative (Fig. 9).

Yarns and Threads: Colored yarns, embroidery silk, and cotton or silk thread. All the threads may be self-colored, of harmonizing colors, or of contrasting colors. Use self-colored thread for invisible stitching to attach ribbons and other decorations.

Buttons, Sequins, and Other Ornaments: Buttons or sequins can be used instead of other decorations (Fig. 5). Lapel or scatter pins are adaptable for this purpose.

Additional Materials: The hat in Figure 4 has felt flowers applied. Paper for patterns and cleaning fluid or soap and cool water.

TOOLS

Pencil, ruler, plain scissors or pinking shears if available, large darning needle, thimble, pins, razor blade, and thumbtacks.

PROCEDURE

1. Prepare the felt as described in Section 4, "Felt and Plastic Cosmetic Kit," step 2. Brush the material gently before and after drying.
2. Using paper and pencil, take the measurements from the back of the head of the child who is to wear the bonnet (Fig. 1). Straighten the top and side edges of this pattern with a ruler and curve the bottom edge around the rim of a saucer. Figure 3 illustrates the process of measuring the brim for the pattern shown in Figure 2.
3. Pin the patterns to the felt as shown in Figure 8, and cut with plain or pinking shears.
4. Remove the paper patterns, pin the two felt pieces together, and place them on the wearer's head. Trim if necessary and adjust the bonnet to fit.
5. Figures 4, 5, and 6 show the various styles, types of stitching, and decorations. The brim pattern (Fig. 2), also shows two types of stitching enlarged. Do all necessary stitching and decorating.

CHILD'S SWISS BONNET

MADE FROM
OLD FELT HATS.



Fig. 7.

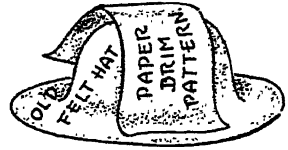

Fig. 8.



Fig. 9.

NEEDLE & FELT
HATPIN.

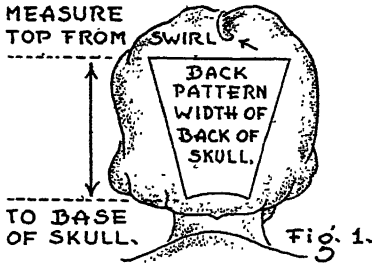

Fig. 1.

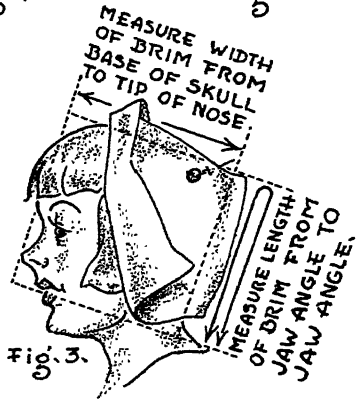

Fig. 3.

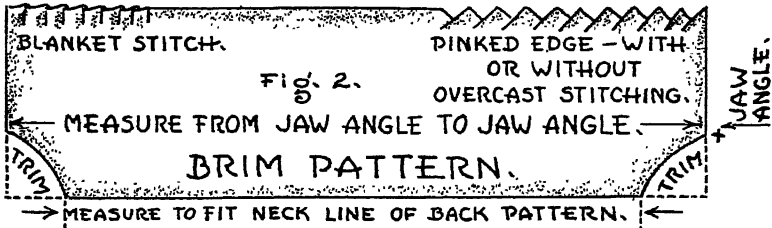

Fig. 2.

BRIM PATTERN.

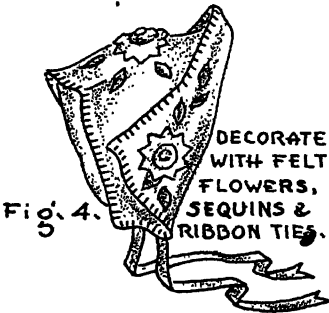

Fig. 4.

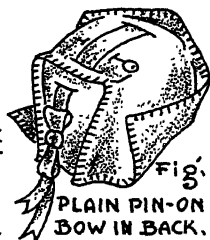

Fig. 6.

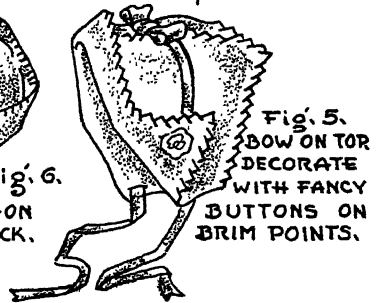

Fig. 5.

BOW ON TOP
DECORATE
WITH FANCY
BUTTONS ON
BRIM POINTS.

PULLMAN SLIPPERS AND CASE

MATERIALS

Felt: At least two felt hats are required, either men's or women's, depending upon the color desired. Men's hats, being of heavier felt, make better soles for slippers (Plate 38). The entire slipper may be made from material of the same color, although it is suggested that two harmonizing colors be used. Use the darker and heavier felt for the soles, the brighter colors and lighter-weight felt for the remainder of the slippers.

Threads: Embroidery silk or cotton, or colored yarns for both decorative stitching and for attaching the soles to the upper portions of the slippers.

Added Decorations: Beads or nailheads from discarded dresses or scarves can be used to embellish the tongue of the shoe. A felt or ribbon bow might be desired in place of beads or nailheads. Yarn tassels or pompons, the same color as the stitching, would be attractive.

TOOLS

Pencil, plain scissors or pinking shears if available, pins, a razor blade for making the fringe, and a darning needle for stitching.

PROCEDURE

1. Have the person who will wear the slipper, place one foot on a piece of tissue paper and trace closely around it (Fig. 2). Cut out the pattern on the pencil line. This pattern will be reversed for the other sole.
2. Using a piece of tissue paper, mold the upper pattern over the same foot for which the sole pattern was made. When the upper pattern is molded and fits well, trace with a pencil around the edge of the foot as before (Fig. 3). Cut out the pattern on the pencil line. This pattern is also reversed for the other foot.
3. Pin both patterns to the felt hats and cut the two felt pieces about $\frac{1}{4}$ in. away from the pencil lines. (Figure 7 shows how the pattern

PULLMAN SLIPPERS AND CASE

made from
MEN'S & WOMEN'S FELT HATS.

EMBROIDERY SILK OR COTTON,
OR COLORED YARN FOR DECORATIVE STITCHING.

PAPER FOR PATTERNS & TRACING PENCIL,
SCISSORS, PINS, RAZOR BLADE & DARNING NEEDLE.

BEADS, NAILHEADS, RIBBONS OR YARN
FOR POMPONS OR TASSELS.



USED FELT MAY
BE CLEANED WITH
HOUSEHOLD CLEANER
OR MILD SOAP &
COOL WATER,
THEN STRETCHED
WITH PINS
ON A BOARD.

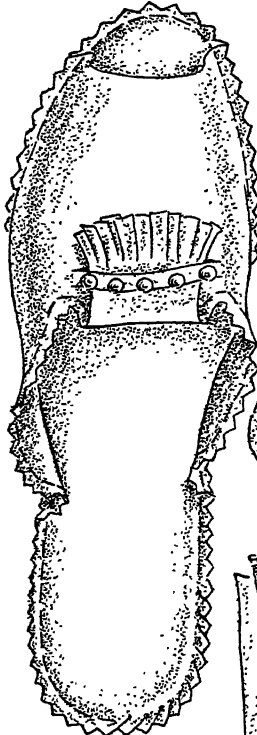

Fig. 1.

NOTE: TWO TYPES
OF STITCHING ABOVE.
EITHER MAY BE
USED - NOT BOTH.

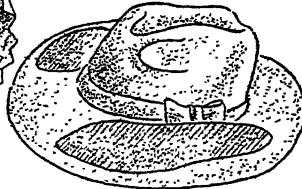

Fig. 7.

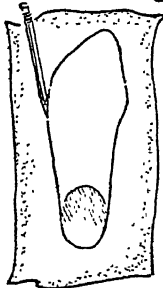

Fig. 2.

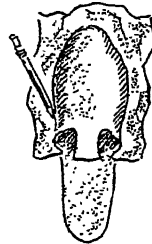

Fig. 3.

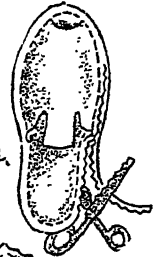

Fig. 4.

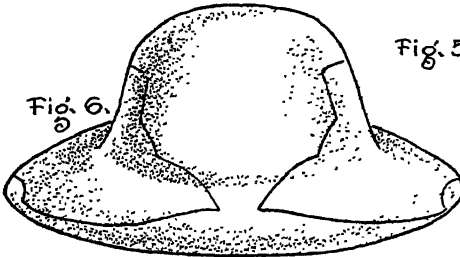

Fig. 6.

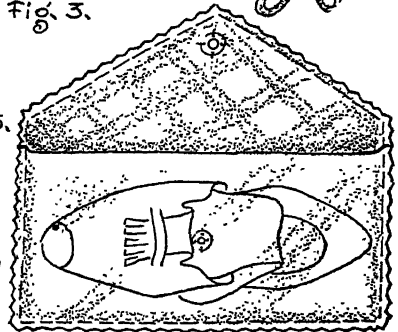

Fig. 5.

for the sole is placed on the hat. Figure 6 shows how the pattern for the upper portion of the slipper is located.) Then pin the patterns to the hats in reverse position and cut with plain scissors.

4. Prepare the fringes and slits in the upper portions of the slippers as shown in Figure 1.
5. Match the upper portions of the slippers to the soles and baste the slippers while fitting them to the foot. When each slipper fits, stitch the upper portions to the soles with short running stitches. Conceal the beginning and ends of the stitching (Fig. 1).
6. Trim the soles with pinking shears as shown in Figure 4.
7. Add the decorations.
8. If the traveling case (Fig. 5) is desired as part of the slipper project, make it according to the instructions in Section 4, "Felt and Plastic Cosmetic Kit."

FELT AND YARN TOY BUNNY OR BEANBAG

MATERIALS

Felt, Glazed Chintz, Oilcloth, or Plastic: Enough colored material to make both sides of the body (Plate 39). Use material of contrasting color for the ears.

Yarn: Sufficient yarn, the same color as the ears, to make two pompons for the tail.

Thread: Bright harmonizing colored yarn or carpet warp to stitch the two halves of the rabbit together. Also pink embroidery floss for the nose and mouth.

Cotton: Clean cotton torn into tufts for stuffing.

Buttons: Two pearl buttons or beads of any desirable size and color for the eyes.

Other Materials: Paper for patterns, cleaning fluid, or soap and cool water.

TOOLS

Pencil, scissors, large needle, thimble, pins, and clothes brush.

TOY BUNNY ^{from} SCRAPS OF FELT, FUR, PLASTIC, GLAZED CHINTZ, OR CALICO.

DOMPON
 PATTERN
 FOR TAIL.
 MAKE 2.

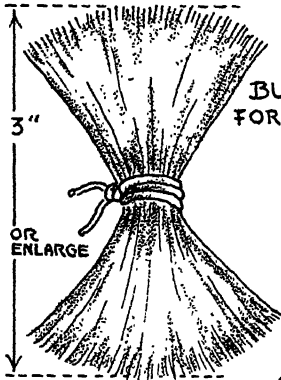

Fig. 4.

TWO
 BUTTONS
 FOR EYES.

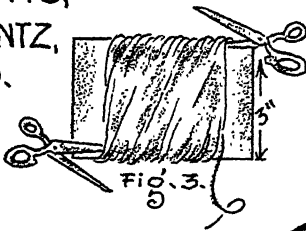
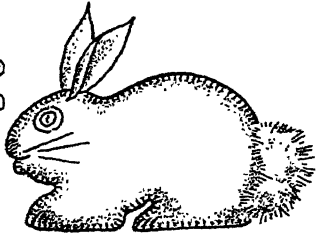
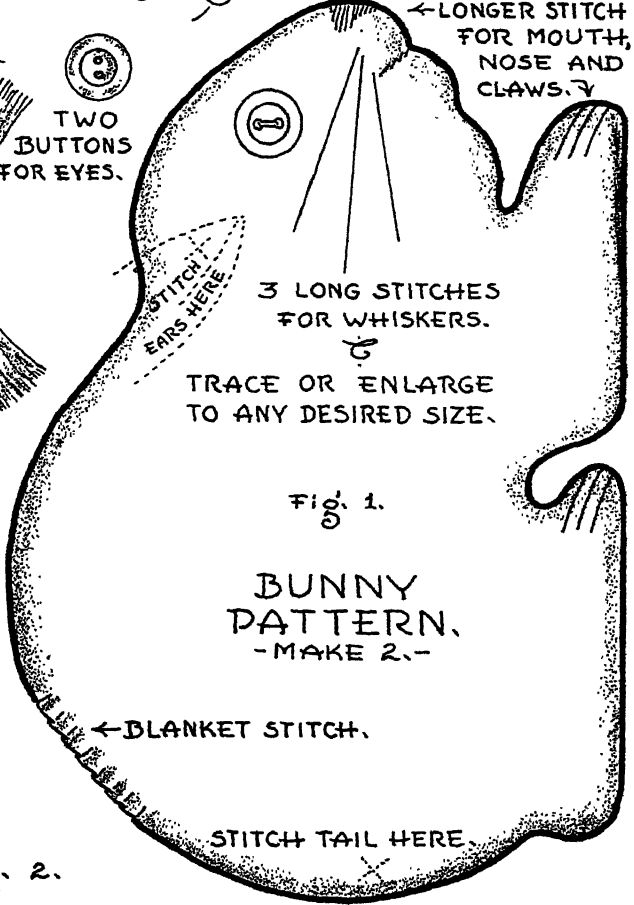

Fig. 3.

← LONGER STITCH
 FOR MOUTH,
 NOSE AND
 CLAWS.



3 LONG STITCHES
 FOR WHISKERS.

TRACE OR ENLARGE
 TO ANY DESIRED SIZE.

Fig. 1.

BUNNY
 PATTERN.
 - MAKE 2. -



Fig. 2.

PROCEDURE

1. Trace or enlarge the pattern for the body of the toy shown in Figure 1. Cut out the pattern and pin it to a double thickness of the material chosen. Be sure to reverse one thickness of the material to insure the right side of the material showing on both sides of the toy. Cut around the pattern with plain scissors.
2. Trace or enlarge the pattern for the ears (Fig. 2). Cut out the paper pattern and pin it also to a double thickness of the material as suggested for the body.
3. On a piece of stiff cardboard about 5 in. long and 3 in. wide, wind the yarn to be used for the tail (Fig. 3). Make the tail as bushy as desired and clip as illustrated. Remove the yarn from the cardboard, tie it tightly in the middle, and fluff it into a ball or pompon (Fig. 4). Make two pompons for the tail.
4. Note that the ears have two points at the sewing end (Fig. 2). Fold one point over the other and attach the ears with self-colored thread as indicated in Figure 1. With white twine, sew the three whiskers to each half of the body as indicated (Fig. 1).
5. Using a blanket stitch with colored thread or carpet warp, sew the sides of the body together. Begin at the heels and stop at the toes, leaving the base open for stuffing.
6. Stuff the animal with cotton and continue stitching across the base, using the same blanket stitching.
7. Sew in the mouth and nose with pink embroidery thread. Then attach the two pompons, or tail, by sewing back and forth through the body. Fluff the two pompons together. Attach the bead or button eyes in the same manner as the tail.

NEEDLE BOOK AND THIMBLE HAT

MATERIALS

Felt: One lady's felt hat of the shape and color desired for the needle book and thimble hat in Plate 40.

Ribbon: A few inches of bright harmonizing colored ribbon for a hatband and bow. A strip of felt may be used instead of a ribbon.

NEEDLE BOOK & THIMBLE HAT

made from
LADIES' DISCARDED FELT HATS.

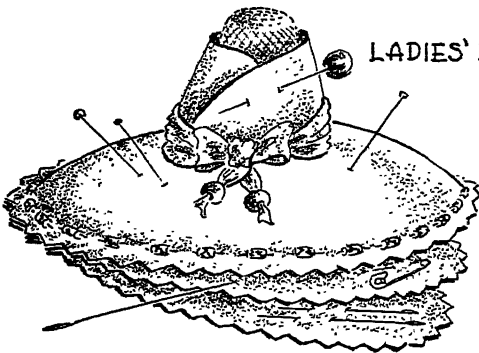

Fig. 1.

RIBBONS & BEADS~
SMALL FELT FLOWERS.
COTTON FOR STUFFING,
EMBROIDERY THREAD,
FLANNEL SCRAPS.

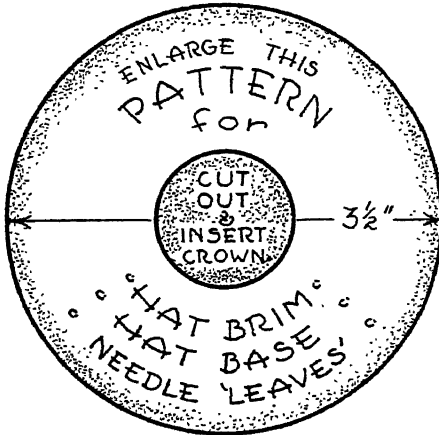

Fig. 2.

SCISSORS, PINKING
SHEARS, PAPER FOR
PATTERNS & PENCIL
FOR TRACING.
NEEDLES AND PINS
FOR NEEDLE BOOK~
A THIMBLE FOR HAT.

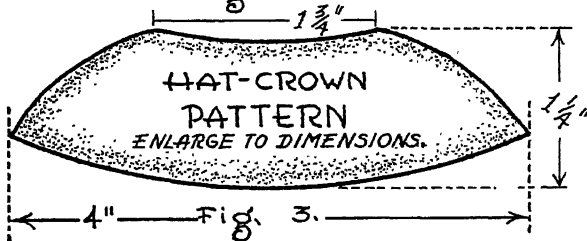

Fig. 3.

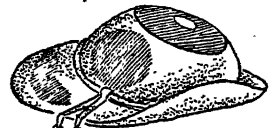

Fig. 4.



Fig. 5.

Plate 40

Flannel: Scraps from a man's worn flannel or plaid woolen shirt or lightweight felt scraps in a color harmonizing with the felt for the thimble hat. These will be used as the leaves in the needle book.

Cotton: Enough quilting, absorbent cotton, or kapok from a discarded sofa pillow for stuffing the cushion part of the hat.

Threads: Self-colored cotton thread of the same color as the felt used, or embroidery silk or colored yarn to stitch the thimble hat together.

Decorations: In addition to the hatband or in place of it, small bright-colored felt flowers or sequins may be sewed on the brim of the hat. Also, use at least one large corsage pin with a bright-colored head as a hatpin. Other straight pins, safety pins, and needles are needed for the pincushion which is the brim of the hat, and some for the leaves of the needle book. A thimble is also needed to insert into the crown.

TOOLS

Pencil and paper for making patterns, plain scissors, pinking shears if available, large darning needle for sewing, and pins for holding the pattern to the felt while cutting.

PROCEDURE

1. Secure a lady's felt hat of the color and shape desired. Clean the hat with either cleaning fluid or soap and cool water. Let it dry thoroughly.
2. Make the patterns for the brim and crown (Figs. 2 and 3). Cut out the patterns and pin them to the felt hat as shown in Fig. 4.
3. Using plain scissors for the crown and pinking shears, if available, for the brim, cut around the paper patterns. Note that two circular pieces the size of the brim are needed. The one for the brim top will be convex shaped for the pincushion and should be cut from the top of the crown of the lady's hat as shown in Figure 4. The other circular piece is for the base part of the pincushion. It is suggested that the latter be cut from a flatter part of the hat. A hole should be cut in the center of the convex circular piece through which the crown will be inserted and stitched to the brim (Fig. 2).

4. Using the pattern in Figure 2, cut two or more leaves from scraps of flannel from a man's worn shirt.
5. Insert the crown through the opening in the convex brim piece and stitch securely with self-colored thread or concealed stitching. Then attach the flatter brim piece with silk floss in long outline stitches, leaving an opening for stuffing. Stuff lightly with cotton and finish the stitching.
6. Attach the flannel leaves at one edge only and add the hatband, flowers, or sequins. Insert the hatpin as in Figure 1 and the collection of odd pins into the cushion and among the leaves. Insert the thimble into the opening in the crown and the project is finished.

SECTION 5 — GLASS

HANG A DECORATIVE PLATE OR PICTURE WITHOUT A FRAME

MATERIALS

NOTE: Level Plate Hangers are easy to make and are inexpensive. Many homes and studios have interesting plates to suit this project. Pic-Quik Corners are the solution to the exhibitor's problem of not having enough picture frames. Made for a school exhibit, they will last for years and can be used over and over again. When used in the home, Pic-Quik Corners allow for a quick, easy change when a new print is desired on the wall. The lacing wire is merely loosened, the old print removed, and the new one inserted. The wire is tightened and the picture hung.

Glass and Cardboard: Picture glass from an unused picture. Matching cardboard of the same size as the glass, and a flower print or etching reproduction to be framed. Also cardboard of the same size for backing the picture (Plate 41, Fig. 2).

Metals: Scraps of air-duct aluminum for the Level Plate Hangers and Pic-Quik Corners. This metal may be obtained at a tinsmith's or furnace shop. Enough picture wire for hanging the picture or plate (Figs. 5 and 6).

Plates: Plain white or tinted plates are best for this project, although an uncolored raised design on the rim of the plate is acceptable. Any desired size may be chosen.

Paints: Plates may be decorated with colored enamels or appropriate decals purchased at the dime store. Designs cut from wall-papers or from glazed chintz are interesting (Fig. 4).

TOOLS

Tin snips for cutting the metal, metal file to smooth the edges, steel wool for polishing, nail to form the wire grip, and steel-edged ruler and razor blades to cut the mat for the picture.

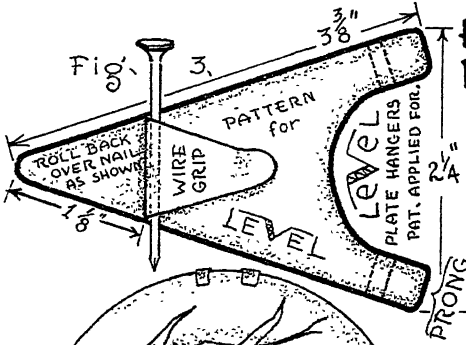

HANG DECORATIVE PLATE OR PICTURE WITHOUT A FRAME

SEE INSTRUCTIONS

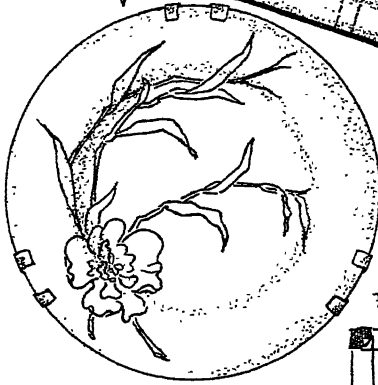

Fig. 4.

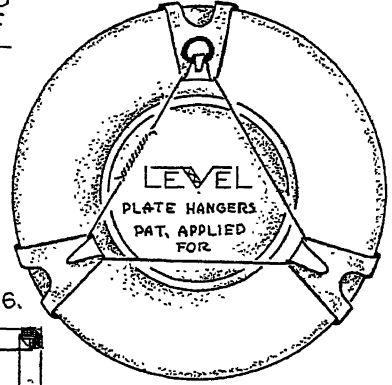
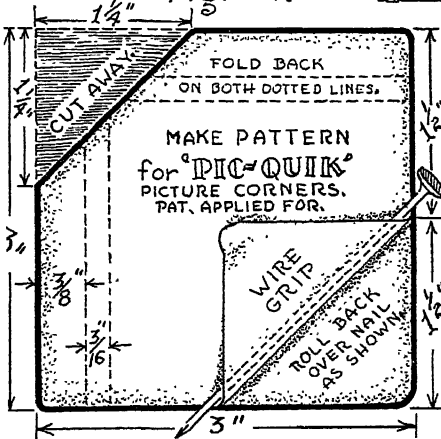

Fig. 5.



METAL PICTURE CORNER

Fig. 1.

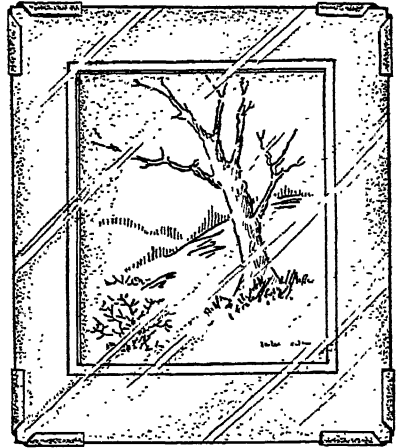

Fig. 2.

PROCEDURE

Decorative Plate

1. Select the plate or plates to be decorated and trace around one on paper. Develop the desired design on this paper. This design will serve as a pattern and guide for painting on the dish (Fig. 4).
2. Using the design in Figure 3, make a pattern for the hangers, and lay out three on aluminum.
3. Cut out the hangers with tin snips and polish the edges and surface of the metal with steel wool. Rub with steel wool in one direction only. Use a large nail to bend the wire grip as indicated in Figure 3.
4. Place the hangers on the back of the plate, one at a time, and with the fingers bend the prongs over the edge (Fig. 5). Place a wire or plastic ring in the top hanger and lace all three hangers to the plate with picture wire.

Picture Without a Frame

1. Using a steel-edged ruler and razor blade, cut a window in the picture mat and attach the picture at the top on the back of the mat. Clean the glass and lay it over the matted picture and use cardboard backing.
2. Make a pattern for Pic-Quik Corners (Fig. 1) and lay out four on aluminum. Finish the corners like the hangers (step 3 above). Shape the corners of the hangers over a large steel or wood file. Note carefully which dotted lines fold forward and which backward. If the metal is too stiff for modeling with the fingers, use pliers and remove scratches with steel wool when finished. As indicated in the illustration, roll the wire grip back over a nail.
3. Place the four corners on the picture, and using picture wire, lace the corners together on the back of the picture as illustrated in Figure 6. The picture may be hung with the lacing wire as illustrated.

DECORATIVE MIRRORS AND MIRROR PICTURE

MATERIALS

Mirrors: An inexpensive or unused mirror (Plate 42). Mirrors with a beveled edge, chipped edge, plain edge, or frame can be used. The mirror can be of any size.

Glass: If there is to be glass over the mirror as in Figure 3, use window glass or picture glass cut to the same size as the mirror.

Metal Foils: The decorative tin foils used by florists, or gold or other colored foils from candy bars, candy boxes, greeting cards, and packaged tobaccos will be needed to complete the project shown in Figure 1.

Pressed Flowers or Flower Prints: Pressed flowers or flower pictures cut from a seed catalog are required for the mirror in Figure 2. Flowered chintz also can be used.

Paints: The mirror picture in Figure 3 is a mirror with a picture painted on the surface. Colored enamels or car touch-up paint can be used.

TOOLS

Pencil and paper for developing the design which will be traced on the back of the mirror shown in Figures 1 and 2. A sharp penknife or single-edged razor blade for scratching the designs into the mirror. Use the original cardboard backing and wire to finish the mirror picture. If new ones are desired, be sure that the cardboard is the same size as the mirror.

PROCEDURE

Mirrors Shown in Figures 1 and 2

1. Remove the backing for the mirrors shown in either Figure 1 or 2.
2. On a piece of paper the same size as the mirror, develop a design appropriate for the place where the mirror will hang. Reverse the drawing on the silvered backing of the mirror by tracing with

DECORATIVE MIRRORS

and

MIRROR PICTURE

made from

INEXPENSIVE OR DISCARDED
MIRRORS- BEVELED EDGED OR
FRAMED.

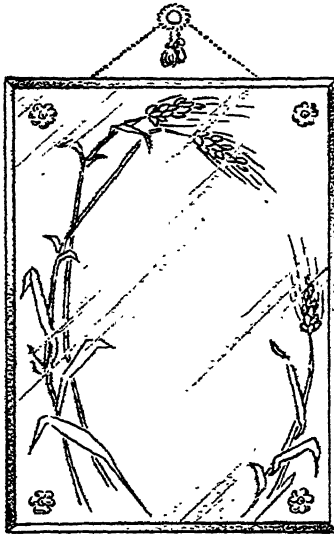

Fig. 1.

Fig. 1. REVERSE DRAWING ON SILVERED BACK- SCRATCH THRU SILVER WITH SHARP PENKNIFE OR RAZOR BLADE & APPLY GOLD-FOIL BACK.

Fig. 2. TRACE AROUND PRESSED FLOWERS ON MIRROR'S SILVER BACK- SCRATCH AWAY SILVER & PLACE THE PRESSED FLOWERS IN OPENING. BACK UP WITH CARDBOARD.



Fig. 2.

Fig. 3. PAINT PICTURE ON GLASS. SET OVER MIRROR IN A FRAME. (SEE DESCRIPTION FOR INSTRUCTIONS.)



Fig. 3.

Plate 42

either carbon paper or blackboard chalk rubbed on the opposite side of the drawing.

3. With a sharp penknife or razor blade, scratch the outline of the design into the silvered surface. If large areas of the silver are to be removed as in Figure 2, use the flat edge of the razor blade.
4. Complete the mirror by one of the three following methods. In either of the three processes, a cardboard backing should be attached with tape or rubber cement before hanging.
 - a) Back up the mirror with a sheet or scraps of colored tin foil as shown in Figure 1.
 - b) Place pressed flowers or pictures of flowers in the openings which have been scratched to the exact size and shape of the flowers to be used as shown in Figure 2.
 - c) Outline the edges and details of the flowers in black enamel and paint in the flowers with transparent water colors and back them up with silver tin foil.

Mirror Shown in Figure 3

1. Develop the design as described above and trace it on the surface of the mirror.
2. Paint the design as any picture would be painted.
3. When the paint is dry, clean the mirror glass in the background and polish the glass which is to cover the mirror.
4. Place the glass over the mirror and set them into a frame. Secure the mirror and glass to the frame with small nails at the back, cover the entire back of the picture with paper or cardboard to keep out the dust, and hang the completed project with the original wire found on the frame. Salvage wire and screw eyes from an old picture if a new frame is to be used.

STUDIO BOTTLE

MATERIALS

Bottles: Although most bottles have decorative possibilities, certain types are more attractive than others. Fancy wine bottles of

all shapes and color, interesting jugs, perfume bottles, and a large bottle from a discarded water cooler are particularly good (Plate 43).

Paints: Enamels, oil paints, and commercial products are splendid media for painting on glass.

Raffia and Colored Fish Cord: Some wine bottles are partially or entirely covered with reed or straw. Although this serves as an adequate background for painting, some craftsmen prefer "embroidering" the design into the straw with colored raffia (Fig. 3). Heavy, colored fishline when wrapped around a glass bottle will give an interesting effect.

Other Materials: Alcohol and shellac.

TOOLS

Darning needle to apply raffia.

PROCEDURE

1. Wash the bottle to be decorated. Clean it with alcohol before painting.
2. On a piece of paper, draw in outline a design which will be in harmony with the function of the bottle. Draw the design to the exact size required and trace it on the glass using either carbon paper, or by rubbing blackboard chalk on the back of the drawing before tracing.
3. Decorate the bottle using the medium desired. Some bottles have raised designs. Painting is thus made easy since only the raised areas need be painted. Always be sure that the color scheme will harmonize with the place where the bottle will be used.
4. If bright-colored fish cord is to be used to decorate the bottle, wind stripes varying in width and color at the top and bottom of the bottle. Adhere the cord to the glass with clear shellac or nail polish, applying an additional coat or two when finished.
5. Draw designs on straw covered bottles with a pencil and weave the design into the background with colored raffia as one might embroider on cloth. Use a large darning needle. When finished, a coat of clear shellac over both the straw background and raffia design will preserve the straw and add luster.

DECORATE A STUDIO BOTTLE

USE A BOTTLE FROM WATER COOLER, SHAMPOO BOTTLES, FANCY WINE BOTTLES & INTERESTING JUGS.

DECORATE WITH LACQUER & ENAMEL.

PLACE IN STUDIO, PATIO, DEN, OR RECREATION ROOM.



Plate 43

HOW TO CUT GLASS BOTTLES

MATERIALS

Bottles: Select the bottle or bottles best suited for the purpose. A gallon bleach bottle will make a fine aquarium or indoor garden, and ginger ale bottles, green or clear, can be used for tumblers, vases, or lantern globes.

Paint or Enamel: Paint or enamel can be used to decorate the bottle (Plate 44, Fig. 6).

Wood: Wood for the cutting box shown in Figure 7.

Other Materials: Bottles may be cut with yarn and kerosene (Fig. 1) and hot paraffin and cold water (Figs. 2 to 6).

TOOLS

Glass cutter and staples to anchor it, a coffee can for heating wax, and a funnel for pouring.

PROCEDURE

NOTE: Cutting a glass bottle is a game of chance at best. The average is about one clean cut out of three. Even your glazier won't guarantee cutting every bottle. Below are three methods of glass cutting for your experimentation.

First Method

Dip wool yarn into kerosene and wind it loosely (three times) around a (cold) bottle at the cutting line. Lay the bottle on its side on a table, with the yarn over the edge. Ignite the yarn with a match and turn the bottle slowly as the flame follows the yarn. When the flame has encircled the bottle, continue to turn it until the bottle cracks. If it does not break after a moment, tap the glass a little above the cutting line with the handle of a table knife. If the glass refuses to break, cool the bottle and repeat the process. File and sand the edge until it is frosty in appearance. Then decorate as desired.

HOW TO CUT GLASS BOTTLES

USING KEROSENE & YARN—HOT PARAFFIN & COLD WATER—OR A GLASS CUTTER IN A BOX—EVEN YOUR GLAZIER WON'T GUARANTEE CUTTING YOUR BOTTLES, BUT HERE ARE 3 WAYS TO TRY—BE SURE TO HAVE SOME SPARES IN CASE OF BREAKAGE!!!

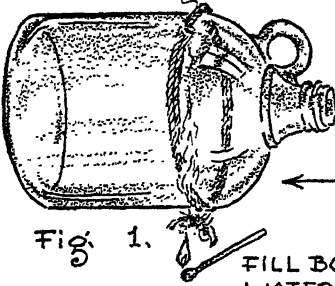

Fig. 1.

DIP YARN INTO KEROSENE—WRAP TIGHTLY AROUND BOTTLE & SET AFIRE.

FILL BOTTLE WITH WARM WATER—POUR IN WARM WAX—CHILL BOTTLE & POUR IN HOT WAX. →

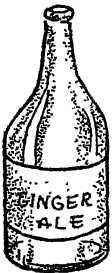

Fig. 2.

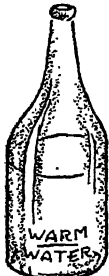

Fig. 3.



Fig. 4.



Fig. 5.

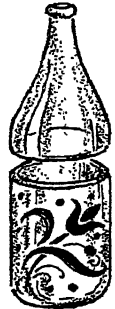

Fig. 6.

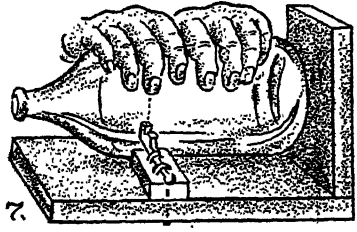
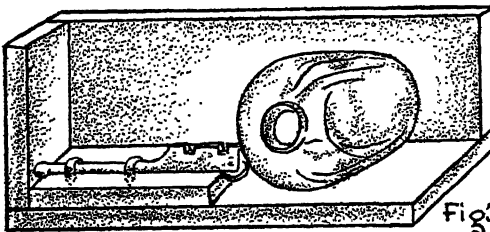

Fig. 7.

Plate 44

Second Method

Refer to Figures 2 to 6. Fill the bottle to slightly below the cutting line with warm water. Melt paraffin in a coffee can and let it stand until warm. Using a funnel so that no paraffin will touch the glass except at the cutting line, pour about $\frac{1}{2}$ cupful of warm paraffin over the water. Then place the bottle in a refrigerator until ice cold. Again heat the paraffin until boiling, and, using a funnel, pour about a cupful of hot paraffin over the now solid paraffin in the bottle. Make sure that no paraffin touches the glass except where it flows out from the center of the cold, solid wax. The glass should crack immediately to a clean, smooth edge. Measure each successive bottle to match the first if a set of tumblers is your goal. Finish as described under first method.

Third Method

When a glass cutter is to be used, anchor the cutter to a table top or box (Fig. 7). The distance of the cutter from the wall should be the same as the measurement between the cutting line and the bottom of the bottle. With considerable force, push and roll the bottle forward against the cutting tool and at the same time keep the bottom of the bottle against the wall. Increase the pushing force as the bottle is rolled away from the body, until the glass begins to cut. Be sure that the cut is continuous all around the bottle. After the cutting is completed, tie an iron or steel bolt to a string and suspend it into the bottle to exactly the cutting line. Swing the bolt back and forth, tapping on the glass. This tapping on the glass should cause the cutting edge to break even, completely around the bottle. Finish as described under first method.

HURRICANE LAMPS AND LANTERN

MATERIALS

NOTE: Both the lantern and hurricane lamp are useful and decorative for a summer cabin, camp, or home. The lantern is a good stage prop when used for pageants. For this purpose, use an amber bottle and a small flat flashlight in the bottom.

HURRICANE LAMPS and LANTERN.

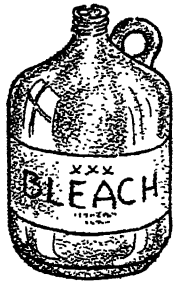

Fig. 7.



Fig. 8.

LANTERN NEEDS 31b. SHORTENING CAN, 2qt. BLEACH BOTTLE, CLOTHES LINE WIRE, GALLON TIN CAN. FOR HURRICANE LAMP USE QT. GINGER-ALE BOTTLE, SHORTENING-CAN LID OR BIRCH SLABS FOR BASE. PUNCH HOLES IN TOP AND BOTTOM OF LANTERN FOR AIR.

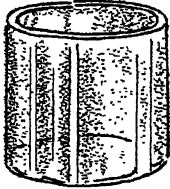

Fig. 9.

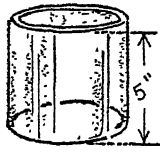

Fig. 10.

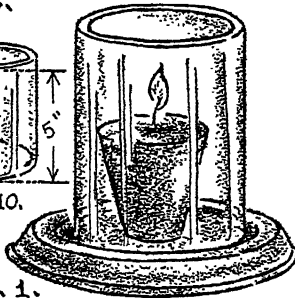

Fig. 1.



Fig. 2.

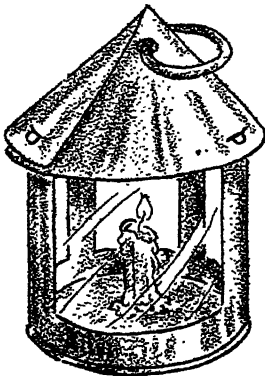

Fig. 3.

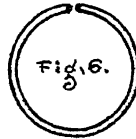

Fig. 6.

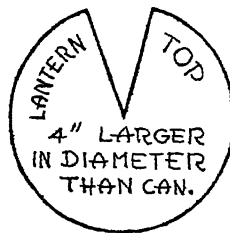

Fig. 5.

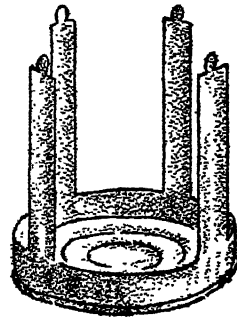

Fig. 4.

Plate 45

Glass Bottles: A 2-qt. bleach or cider glass jug for the lantern or large hurricane lamp (Plate 45, Figs. 7 and 8). A ginger ale bottle for the smaller lamp. A 1-gal. jug for the larger lantern. Have some spare bottles handy in case of breakage.

Metal and Wire: For the lantern, a 3-lb. shortening can should be used (Fig. 4). The 2-qt. bleach bottle will fit into this size can. The lantern will also require a 1-gal. can from which the top of the lantern will be cut (Figs. 3 and 5). A metal or plastic ring or one made from heavy wire should be used for the handle of the lantern (Figs. 3 and 6). The lid of the shortening can, when decorated, will make an excellent base for a hurricane lamp (Fig. 1).

Wood: If wood is preferred for a lamp base, cut slabs from tree branches (Fig. 2).

Paints: If decoration is desired on either metal or wood bases of the hurricane lamp or on any part of the lantern see Section 5, "Decorative Mirrors and Mirror Picture." The process is the same.

TOOLS

Tin snips or heavy shears for cutting the tin, metal file to smooth the edges and steel wool to polish the metal, large nail and hammer for punching air holes in the lantern and for openings for a handle, and glass-cutting equipment (see Section 5, "How to Cut Glass Bottles").

PROCEDURE

Lantern

1. Using Figure 4 as a guide, cut the base of the lantern from a 3-lb. shortening can. Note the round prongs at the top of each post. These prongs may be either rounded or square and will later be inserted into slots cut in the top of the lantern. Figure 5 shows the pattern for the lantern top which is cut from the one gallon can.
2. Remove both the top and bottom of the gallon can, cut it down the side, and roll it flat. Draw as large a circle as possible on the flat metal and cut out as illustrated. Form the top of the lantern as illustrated in Figure 3. Mark slots and cut them with a cold chisel on hardwood. Use a large nail to punch four air holes in the bottom of the lantern and two in the top for a handle.

3. File all metal edges smooth, polish with steel wool, and give the entire lantern one coat of clear lacquer or varnish.
4. Cut the 2-qt. bottle (see Section 5, "How to Cut Glass Bottles"). This is the globe and should be 5 in. high. Place the globe into the base of the lantern and set a candle on the bottom with melted wax. Attach the top of the lantern to the base by pushing the prongs through the slots and bending them down. Insert the handle which has been made from heavy wire or a plastic handle from a lady's purse. To light the candle, remove only the overlapping part of the top.

Hurricane Lamp

1. Cut out the base and decorate it with enamel or car touch-up paint.
2. Cut the globe to size (see Section 5, "How to Cut Glass Bottles") and decorate it, if desired. A hand-painted ship or any early American design would be effective on the glass globe of the lamp.

SANDWICH TRAY

MATERIALS

Glass: The convex glass used over old-fashioned oval portraits, which may be found in the attics of many homes, make an attractive sandwich tray or flower bowl (Plate 46). Some discarded clocks have round or oval convex crystals; others have square bent glass. These, too, make useful and decorative pin trays or ash trays.

Metals: Scrap air-duct aluminum or flashing copper can be fashioned into beautiful standards for both sandwich tray and ash tray.

Spools or Bamboo: The tape spools from an adding machine or cash register are ready cut and decorative as handles for a glass sandwich tray (Fig. 2). Short sections cut from a bamboo pole also make artistic handles.

Decals or Paints: Although the clear, undecorated beauty of the glass will appeal to some craftsmen, others may prefer to decorate it with original painted designs or decals. If the latter method of decoration is chosen, use reversed decals, because they must be mounted on the underside of the tray.

TOOLS

Saw, sandpaper to shape the handles, tin snips, metal file, machinist's hammer, pliers, and steel wool.

PROCEDURE

Sandwich Tray

1. Smooth and frost the edges of the glass with a metal file and sandpaper (Fig. 2).
2. Prepare the spool handles (see Section 5, "Mirror or Plate Glass Center Piece").
3. Apply painted designs or decals to the underside if desired.

Flower Bowl

1. Enlarge the pattern in Figure 4 to fit the glass tray available.
2. Cut the aluminum or copper metal with tin snips or heavy shears. Polish with steel wool rubbing in one direction only. Place the metal on a smooth, hardwood surface and hammer it with a ball-peen hammer (see Section 3, "Ash Tray or Pin Tray"). If the metal appears warped after hammering, turn it over and flatten it with the flat end of the hammer.
3. Give the metal a coat of clear lacquer or spar varnish and set it on edge to dry.
4. Form the handles and the feet and mold the standard to the glass only after the lacquer has set. The handles act as springs, securing the standard to the glass. Roll the handles over a broom handle and coil the feet in reverse (Figs. 3 and 4).

Ash or Pin Tray

This is made like a sandwich tray or flower bowl (Fig. 6). The feet may be omitted if desired.

SANDWICH TRAY

OR
FLOWER & FLOATING CANDLE
BOWL
&
ASH OR PIN TRAY



Fig. 1.

MADE FROM CONVEX GLASS
FROM OLD OVAL PICTURES
AND SPOOLS FOR HANDLES.

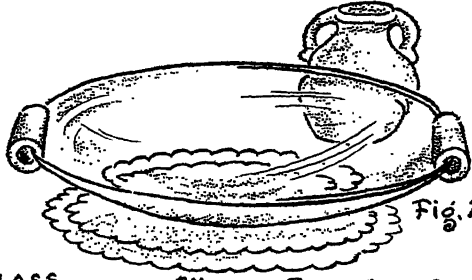

Fig. 2.



Fig. 3.

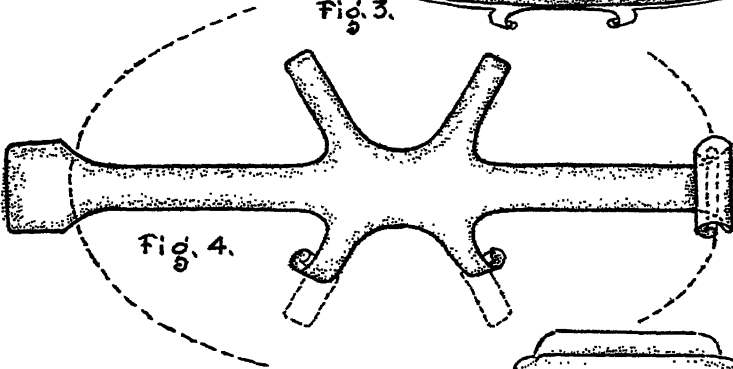

Fig. 4.

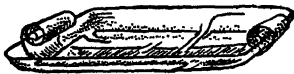

Fig. 6.

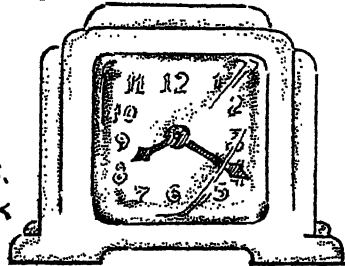

Fig. 5.

MADE FROM BENT-GLASS CLOCK
CRYSTALS & SCRAP METALS.

MIRROR PLACE CARDS

MATERIALS

Vanity Mirrors: A sufficient number of vanity mirrors to make the place cards required (Plate 47, Figs. 1, 3, and 5). One vanity mirror will make a complete place card (Fig. 2). If a sufficient number of vanity mirrors is not available, a large mirror can be cut into smaller ones.

Seals and Prints: Holiday seals or pictures cut from a magazine or colored prints can be used for the place card shown in Figure 1.

Metal Foils: Metal foil from potted plants, the gold from greeting cards, from candy bars, tobacco packages, etc., are excellent for the type of place card shown in Figure 3.

Tempera and Finger Paint: These can be used for decorating (Fig. 5).

Cardboard: The articles shown in Figures 3 and 5 will need a cardboard backing.

Cement: Model airplane cement is good to glue mirrors together because it is invisible and strong. Rubber cement can be used to restore cardboard backing.

TOOLS

Glass cutter, metal-edged ruler, razor blade or sharp penknife for scratching the silver from the back of the mirror (Fig. 3), small paint brush for printing when tempera is used, and a pointed stick to print or write the name into either finger paint or tempera (Fig. 5).

PROCEDURE

Place Card in Figure 1

Cut the vanity mirrors in half for the place card in Figure 1. Use model airplane cement to attach the upright piece to the mirror standard. Let the cement dry thoroughly and the transparent cement will be invisible. Attach holiday seals or small pictures cut from magazines or flower prints to the upright piece and write or print the name with pen and ink or a small, pointed brush and tempera.

MIRROR PLACE CARDS

made from

SMALL VANITY MIRRORS FROM MILADY'S PURSE.



Fig. 1.

USE:

1. INEXPENSIVE GLASS CUTTING TOOL FROM A VARIETY STORE.

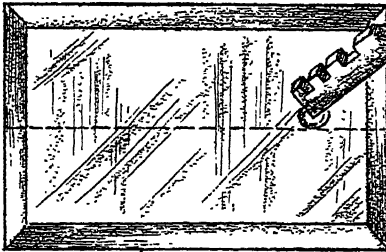

Fig. 2.

2. A METAL-EDGED RULER.

3. GOLD AND COLORED TIN FOIL FROM POTTED PLANTS FOR BACKING ON Fig. 3.

4. DECORATIVE SEALS AND NAIL POLISH.



Fig. 3.

5. FINGER PAINT & TEMPERA FOR FIGS. 1 AND 5, AND A FINE BRUSH.

6. RAZOR BLADE AND SHARP STICK FOR PRINTING AS ON FIGS. 3 AND 5.

7. CARDBOARD AND GLUE FOR BACKING FIGS. 4A & B.

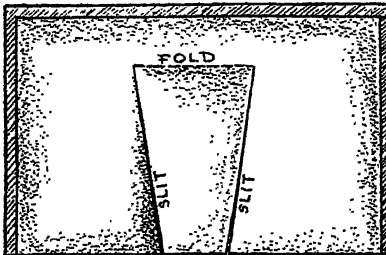

Fig. 4 a.



Fig. 4 b.



Fig. 5.

A piece of cardboard or colored felt from an old felt hat may be used on the underside of the base to keep the glass from marring the table top. Change the designs and the mirror place cards may be used again.

Place Card in Figure 3

Whole vanity mirrors can be used for the mirror place cards in Figures 3 and 5. For Figure 3, trace an appropriate design on the silver backing of the mirror and scratch away the silver with a razor blade or sharp knife. Fill in the open design with colored metal foil. Then attach a cardboard backing (Fig. 4) with rubber cement and write the name in tempera or ink on the surface of the mirror.

Place Card in Figure 5

The mirror in Figure 5 may be covered with tempera or finger paint. If finger paint is to be used, smooth it over the surface with one finger and experiment with a small landscape design. If tempera is to be used, apply it to the mirror and let it dry. Then write the name with a pointed stick. Finger paint requires writing or printing while wet. The clear mirror margin in Figure 5 is accomplished with a soft cloth when the paint has dried.

INDOOR GARDEN UNDER GLASS

MATERIALS

Glass: Broken window panes, broken plate glass from desk tops, large oval or round mirror with defective silver backing, the glass tank from a discarded gas pump and the bottom section of a glass coffee maker for the projects in Plate 48.

Felt: A few scraps of brown, black, or green felt from old felt hats.

Wallpaper and Paper Tape: Suitable designs cut from wallpaper or the decorative matching borders which come with some wallpapers. These will be attached to the glass with masking tape or adhesive tape (Fig. 4).

INDOOR GARDEN UNDER GLASS

made from

DISCARDED MIRROR ~ GLASS TANK FROM OLD GAS PUMP ~
BOTTOM PART OF GLASS COFFEE MAKER ~ WINDOW GLASS.



Fig. 1.

USE:

GLASS CUTTER -
METAL FILE -
FELT & WALLPAPER -
NAIL POLISH -- GLUE.



Fig. 2.



Fig. 3.

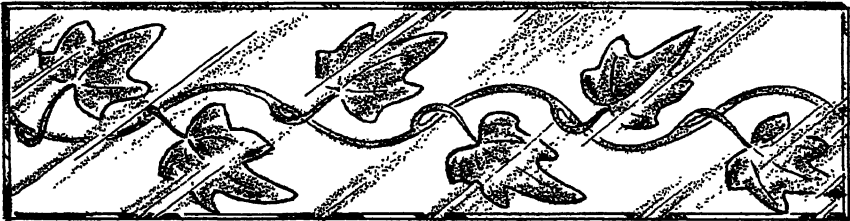

Fig. 4.

Plate 48

Nail Polish: Colored nail polish is optional. The edges of the glass may be painted if desired. Enamels or paint may also be used instead of wallpaper designs (Fig. 3).

House Plants: A large potted plant is attractive in the glass coffee table (Fig. 1). Small house plants will be needed for the Indoor Garden (Fig. 2).

TOOLS

A razor blade to scrape the silver from the back of the mirror (Fig. 1), scissors for Figure 4, paints for Figure 3, metal file and sandpaper for sharp edges, and a glass cutter.

PROCEDURE

Figure 1

Remove the tarnished silver from the back of a mirror with a razor blade, using only the flat sharp edge of the blade. Be sure not to scratch the glass. Clean the mirror glass and the tank glass. Mount four or six spots of colored felt on the top edge of the tank before placing the glass mirror top over it. This will prevent scratching the glass and will also allow air for a plant when placed inside the tank base of the table.

Figure 2

Consult a seed catalog for types of plants and soil recommended for a terrarium, or indoor garden. Plant the flowers in the bottom section of a glass coffee maker or a discarded aquarium. This makes an easy project for small children and will brighten both schoolroom and the home.

Figures 3 and 4

From a broken window pane or a salvaged plate glass, cut either 3-in. squares or strips of glass measuring 3 by 9 in. or 3 by 12 in. The average window sill will accommodate from six to eight of the squares and two of the longer strips. Apply decorative wallpaper or wallpaper borders to the back side of the glass with masking tape or adhesive tape. If desired, paint designs. These glass squares or strips can be placed on the window sills of the home or classroom

to serve as coasters for potted plants. They may also be used as coasters on the dining table. Decorative borders such as these described above may also be applied to the plate glass covering on desk tops in the home or office. Also thicker plate glass cut into squares and decorated in like manner will make attractive paperweights. A paperweight such as this will make an inexpensive gift for children to take home at Christmas time or for Mother's Day. It may be necessary, however, to have a glazier cut heavier glass.

MIRROR OR PLATE GLASS CENTERPIECE

MATERIALS

Glass: Plate glass and oval or square mirrors without frames for the articles in Plate 49. Plate glass from a desk top is often available and most homes have a mirror or two which could be used for this centerpiece.

Metal: Scrap aluminum or copper for the feet. Scrap plastic is also attractive.

Wooden Spools and Bamboo Fishing Pole: Wooden tape spools from an adding machine or cash register or a bamboo fishing pole.

Paints: Paint or enamel.

Other Materials: Sandpaper, clear shellac, varnish, lacquer, steel wool, and model airplane glue.

TOOLS

Saw, wood file, tin snips, and a ball-peen hammer.

PROCEDURE

Centerpiece in Figure 2

1. Use the pattern illustrated in Figure 1 for the snap-on feet made from scrap metal. Make a paper pattern of the same design and trace it on scraps of either furnace air-duct aluminum or flashing copper.
2. Cut the aluminum or copper with tin snips or heavy shears.
3. Polish in one direction only with steel wool.

4. Hammer the metal with a ball-peen hammer, placing it on a smooth, hardwood surface.
5. If the metal is warped after hammering, turn it over and flatten it with the flat end of the hammer.
6. Give the metal a coat of clear lacquer or spar varnish and set it on edge to dry.
7. When dry, bend the metal according to either Figures 3a, 3b, or 3c, using pencils or square sticks to give the desired shape. Make sure that the open part which slides over the glass is narrow and springy. Thus the snap-on foot will act as a spring and hold fast to the glass.
8. To decorate the glass, see the projects "Decorative Mirrors," "Picture Without a Frame," "Decorative Bottles," etc.

Centerpieces in Figures 5 and 6

1. Use either a round or square mirror without a frame.
2. To prepare wooden spools, saw out a slot into which the glass will be inserted (Figs. 4a and 4b). This slot should measure a trifle less than the thickness of the glass when sawed. Then sand to fit the glass snugly without forcing (Fig. 5).
3. When the spools fit the glass, sandpaper, shellac, allow to dry, and sandpaper lightly again. Then give them a coat of clear spar varnish. Use unbent paper clips for hanging spools on a line to dry.
4. Prepare bamboo handles the same as wood handles. Sand the ends only.
5. Apply a small amount of model airplane glue to handles before fitting them to the glass.
6. To decorate the glass, see Section 5, "Decorative Mirrors and Mirror Picture," etc.

MIRROR^y PLATE GLASS CENTERPIECE



TRACE PATTERN OR ENLARGE.



made from

ROUND, OVAL, OR SQUARE MIRRORS WITHOUT FRAMES—OR MADE FROM PLATE GLASS

—with—

"SNAP-ON" FEET MADE FROM SCRAP ALUMINUM, COPPER, OR SCRAP PLASTIC.

—OR—

WOODEN "FOOT HANDLES" MADE FROM TAPE SPOOLS FROM ADDING MACHINE OR BAMBOO SECTIONS,



Fig. 5.

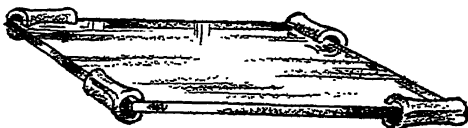

Fig. 6.



Fig. 4b.



Fig. 4a.

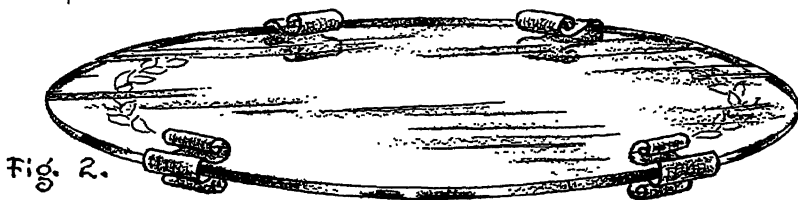

Fig. 2.

Plate 49

BRIGHTEN THE KITCHEN WITH GLASSWARE

MATERIALS

Glass: Glass jars, with lids, of all sizes. For the canister set use jars from salt and pepper size to the large cooky jar size (Plate 50, Fig. 4). Almost all the glass jars needed for the canister set will be found at home, although for the largest piece, the cooky jar, it may be necessary to haunt the grocery or candy store for a large candy, peanut, or marshmallow jar. All jars must have lids that fit snugly. Instant coffee containers can be used for salt and pepper. Peanut butter jars are excellent for refrigerator dishes. Glass coffee or salad dressing jars are best for sugar, coffee, and flour. One or two broken window panes or damaged plate glass from a desk top for the window shelf (Fig. 2), which is suitable for the home, school, or camp. The shelf can be used for potted plants, colored glass ornaments, or miniatures.

Coat Hangers or Wire: Coat hangers in colored enamel can be used as supports for a glass shelf in a small kitchen or bathroom window. Painted, heavy clothes line wire may be used as brackets for larger and heavier shelves.

Paints or Decals: Colored enamels or car touch-up paint, or any of the new commercial products are media for decorating metal or glass. Decalomania may be used by the younger craftsmen or when paint is not available. If desired, letter decals are available for labeling the canister set.

Other Materials: Sandpaper, steel wool, clear lacquer or varnish, and screws to hang the glass shelf.

TOOLS

Metal-edged ruler, glass cutter, hammer and a medium size nail to punch holes in the salt and pepper covers, metal file, pliers, and a screw driver.

PROCEDURE

Glass Shelf

1. The glass shelf is suitable for the home, school, or camp. From a sheet of broken window glass or the plate glass from a desk top, cut a shelf to size and file the edges smooth.

BRIGHTEN THE KITCHEN with "GLASSWARE"

made from

~ ODDS & ENDS ~

FOR WINDOW SHELF FOR FLOWERS ~ CUT THE SHELF FROM A BROKEN WINDOW PANE ~ ATTACH TO WINDOW WITH COLORED COAT HANGERS.

FOR GLASS CANISTER SET ~ USE LARGE CANDY JAR FROM GROCER'S, OR 3 POUND COFFEE JAR FOR COOKIES ~ 1 POUND COFFEE JARS FOR COFFEE, SUGAR & FLOUR ~ LOW PEANUT-BUTTER JARS FOR REFRIGERATOR DISHES ~ 6 OZ. INSTANT COFFEE JARS FOR SALT AND PEPPER SHAKERS.

DECORATE WITH ENAMEL, CAR TOUCH-UP LACQUER AND DECALS FROM YOUR STORE. TOOLS: HAMMER, NAIL, GLASS CUTTER, AND STEEL FILE.

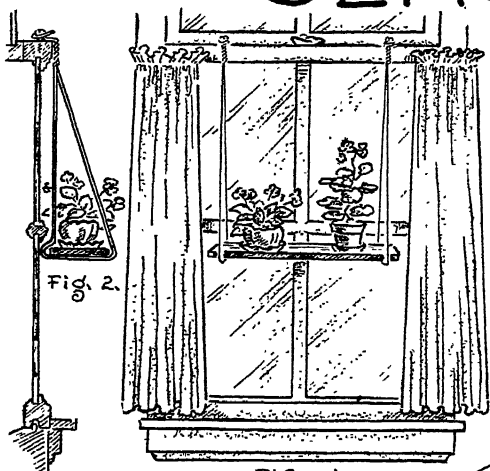

Fig. 2.

FIG. 1.

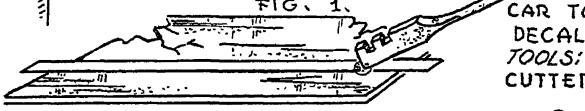

Fig. 3.

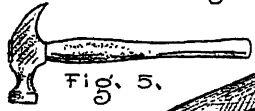

Fig. 5.

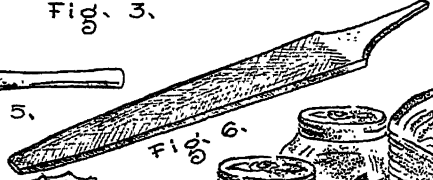

Fig. 6.

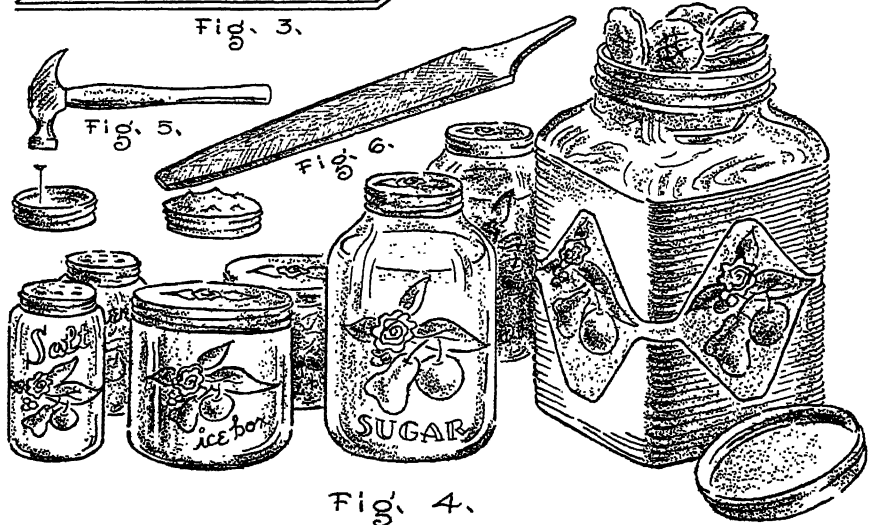

Fig. 4.

2. Using Figure 2 as a guide, form two colored coat hangers to fit both the window it will adorn and the shelf it will hold.
3. Measure on the glass the distance the hangers should be separated, and using the same measurement, mount two screws in the window sash (Fig. 1).
4. With the pliers, straighten the hooks of the coat hangers, shape them over the window frame as in Figure 2, and twist them once around the screws. Cut off any excess length of wire and file the ends smooth.
5. Place the glass in the brackets.

Canister Set

1. Remove labels and paint from covers with sandpaper and steel wool.
2. Punch holes for salt and pepper as illustrated in Figures 5 and 6.
3. Clean the glass thoroughly before painting or applying decals.
4. Use the same design on all pieces and apply smaller ones on the lids, whether decals or painted designs.
5. When dry, cover all designs with a coat of clear varnish or lacquer. Never use shellac over decals because it will curdle them.

SECTION 6 — VARI-CRAFT

POT HOLDER AND T TOWEL RACK

MATERIALS

Wooden Salad Set: A fork and spoon salad set. When not available at home, these hardwood spoons and forks can be purchased in any variety store (Plate 51, Figs. 1 and 3).

Ring for Towel Rack: Any large ring made of wood, metal, or plastic. Plastic handles from a discarded purse, or curtain rings and heavy bent wires will make a ring for the towel rack (Fig. 1).

Metal: Small scraps of aluminum or copper (Fig. 2).

Hooks and Screws: Brass or chrome hooks such as those used to hang cups in cupboard. Two brass or chrome roundhead screws for mounting the towel rack on the wall (Figs. 1 and 3).

Additional Materials: Paper for patterns, carbon paper, sandpaper, steel wool, clear shellac, spar varnish, furniture wax, and paint or enamel if desired.

TOOLS

Pencil, small drill, tin snips, and a metal file.

PROCEDURE

Towel Rack

1. Sand the spoon and fork (Figs. 1 and 3) to a smooth finish and apply one coat of clear shellac. When the shellac is dry, sand again lightly, with worn sandpaper. Apply enamel, if desired. When dry, apply one or more coats of spar varnish, sanding lightly between coats.
2. Using the design in Figure 2, enlarge the pattern on paper to fit the handle of the spoon chosen. Then trace it on the metal with carbon paper. Cut the fixture from the metal with tin snips, file the edges, and polish the metal with steel wool.
3. Bend the middle part of the fixture around a pencil (Figs. 1 and 2) and then bend the ends back to their original position.

POT HOLDER & T-TOWEL RACK

made from

WOODEN SALAD SET - PLASTIC PURSE HANDLE -
SCRAP ALUMINUM OR COPPER - CLEAR VARNISH -
AND BRASS CUP HOOKS

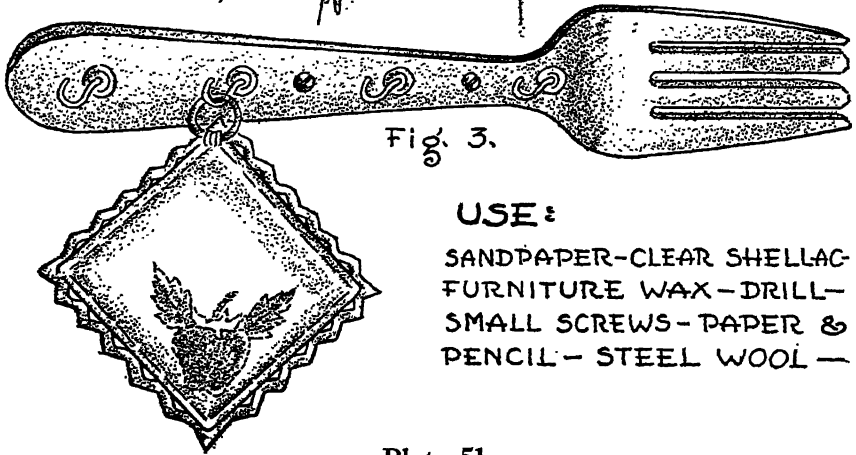
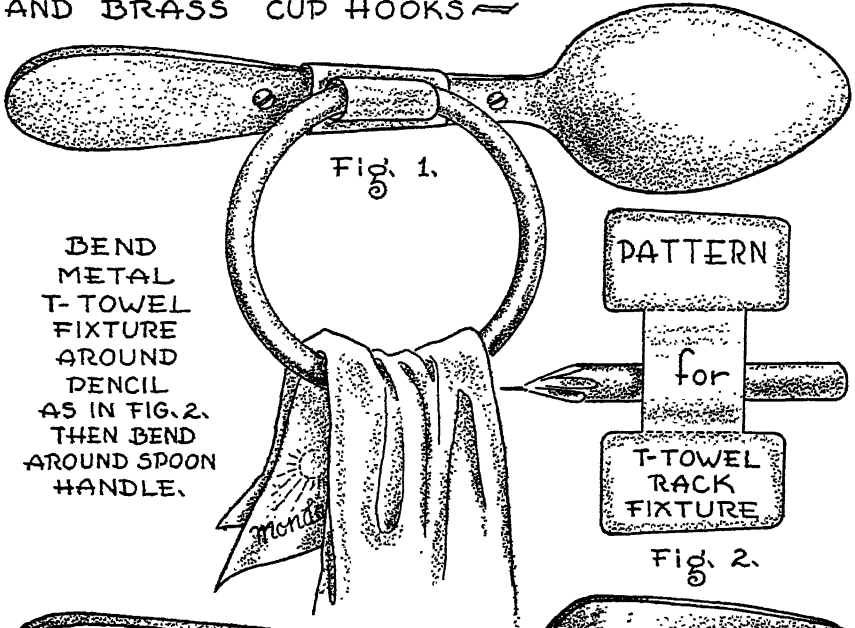

Plate 51

4. Insert the towel ring into the fixture, lay the metal flat against the back of the spoon handle, and hold firmly while bending the flat parts of the fixture around to the back of the handle (Fig. 1).
5. Bore holes for the screws and attach the holder to the wall.

Pot-Holder Rack

Figure 3 is self-explanatory. Bore the screw holes as suggested above, attach the hooks as pictured in the illustration, and screw the unit to the wall near the kitchen range.

Pot Holder

See Section 4, "Hot Dish Holder."

NECKTIE OR TOWEL RACK

MATERIALS

Shells: Large sea shells of the type pictured in all three illustrations in Plate 52.

Plastic, Metal, or Wooden Rings: Plastic rings salvaged from the handles of a discarded purse are best for the necktie or towel rack, since they will bend readily without breaking. Large wooden rings are sometimes used to hang living room draperies and a metal ring can be made from heavy copper or steel wire (Figs. 1 and 2).

Plaster of Paris and Rubber Cement: The rack and stand are filled with plaster of Paris for both strength and weight. A small amount may be purchased at any drug or hardware store. Rubber cement is used if the pen stand is to be made.

Felt: Scraps of felt salvaged from discarded felt hats will serve as a base for the fountain pen stand.

TOOLS

A drill with a bit for boring metal: the drill should be somewhat larger than the diameter of the ring material, or very small for the pen stand. A mixing bowl in which to mix the plaster.

PROCEDURE

Necktie or Towel Rack

1. Since the shell (Fig. 1) cannot be put into a vise for boring the holes, have someone hold it for this operation. Holes should be bored from the sides of the shell and must be larger than the ring material.
2. Bend plastic rings to insert them into the holes of the shell. Saw wooden rings into two pieces, on the diagonal. Sand the segments and give them a coat or two of shellac and at least one coat of wax. Insert them into the shell holes and then glue them together at the seam which shows outside the shell. A wire ring may be made from heavy copper cable or clothes line wire. Bend it around a fruit jar, and then bend it to secure it in the shell. Polish the wire with steel wool to a high luster. Apply a coat of clear lacquer or nail polish to keep it bright.
3. Mix the plaster of Paris in a bowl. Place the shell upside down over a dish or drinking glass to keep it steady and level. When the plaster begins to thicken, pour it into the shell, level with the brim, and let it set for a half hour.
4. Make a hanger for the necktie or towel rack by carving a hole as pictured in Figure 2 while the plaster is still damp. Make the hole larger than the nailhead on which it will hang. Be sure to include the recess for the nailhead as illustrated.

Fountain Pen Stand

1. Fill the shell with plaster of Paris as above.
2. Using glue or rubber cement, attach a piece of felt, larger than the shell, to the base of the pen stand, then with pinking shears cut around the outline of the shell, leaving a border of the felt showing.
3. Bore a small hole into the top of the shell pen stand and fill it with glue. Then bend the pen clip as shown in Figure 3 and insert it into the hole to complete an attractive and useful pen stand for the desk.

NECKTIE BY TOWEL RACK

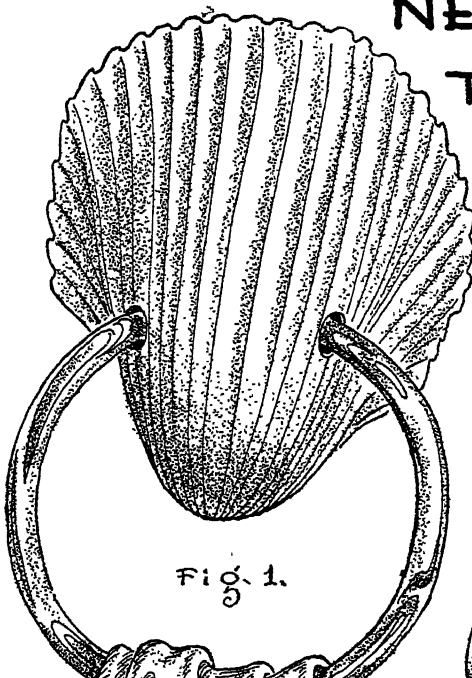

Fig. 1.

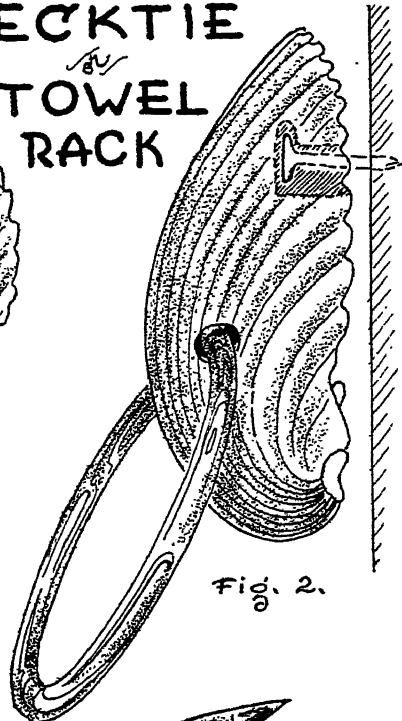

Fig. 2.

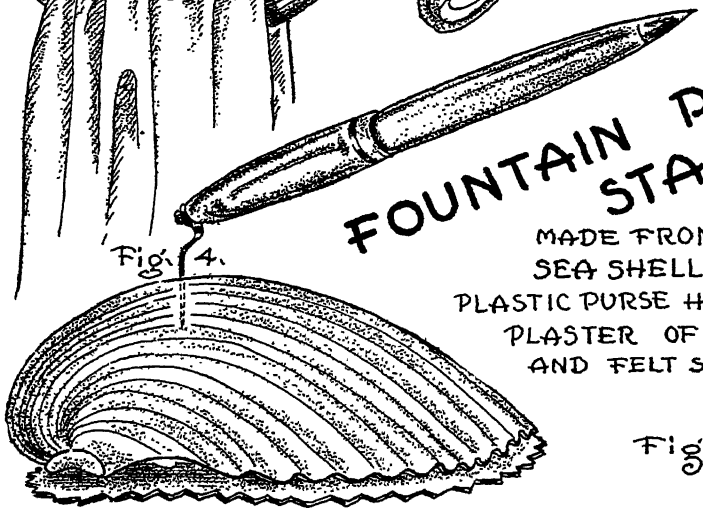

Fig. 4.

FOUNTAIN PEN STAND

MADE FROM
SEA SHELLS,
PLASTIC PURSE HANDLES,
PLASTER OF PARIS,
AND FELT SCRAPS.

Fig. 3.

LAPEL PINS AND EARRINGS

MATERIALS

Teaspoons or Measuring Spoon: A silver or plastic teaspoon or plastic measuring spoon, depending upon the design of the lapel pin (Plate 53, Figs. 5 and 6).

Safety Pins: Any small safety pin, somewhat shorter than the width of the ornament to be made (Fig. 2).

Felt: Small scraps of bright-colored or black felt for backing and other features of the article. Note the ears in Figures 1 and 2.

Paints: Water colors, colored nail polish, or enamels, when color is needed.

Metal or Snapshot: Lightweight aluminum or copper foil or tin foil, if a monogram is to be used. Faces from snapshots or colored flower pictures are effective (Fig. 3).

Plaster of Paris: A pound of plaster of Paris or dental plaster purchased from a drugstore or hardware store will make a number of lapel pins.

Lard or Shortening: Greasing the spoon will prevent the plaster from adhering to it.

Water Colors or Enamels: Used to paint features.

TOOLS

Tin can, water glass, or small fruit jar for mixing the plaster; small, deep dish or fruit jar lid in which to rest the teaspoon or measuring spoon; tea strainer and a spool or some small object to steady the handle while pouring the plaster (Fig. 4); shortening; a small pointed stick or a nail for carving features; and water colors or enamels.

PROCEDURE

Lapel Pins

1. Decide upon the design for the lapel pin. Faces of cute animals are excellent (Fig. 1).
2. Grease the spoon with pure lard or shortening and place it in the position shown in Figure 4.
3. Pour twice the amount of water needed to fill the spoon into a

LAPEL PINS & EARRINGS

made from

PLASTER OF PARIS,
WATER COLOR, CLEAR NAIL
POLISH, FELT SCRAPS, AND
SAFETY PINS.

Fig. 1.

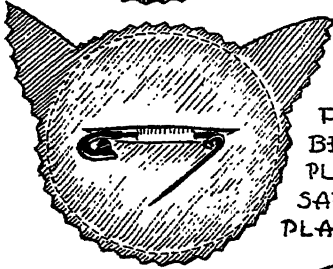
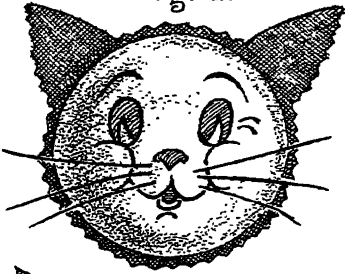
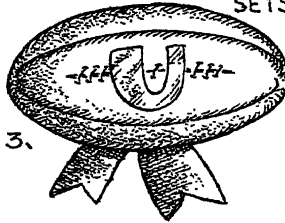

Fig. 2.

GREASE SPOON
LIGHTLY WITH
PURE LARD
BEFORE POURING
PLASTER—INSERT
SAFETY PIN INTO
PLASTER BEFORE IT
SETS.

Fig. 3.



KEEP SPOON
LEVEL WHILE
POURING PLASTER.

Fig. 4.

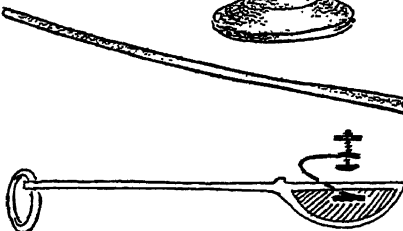
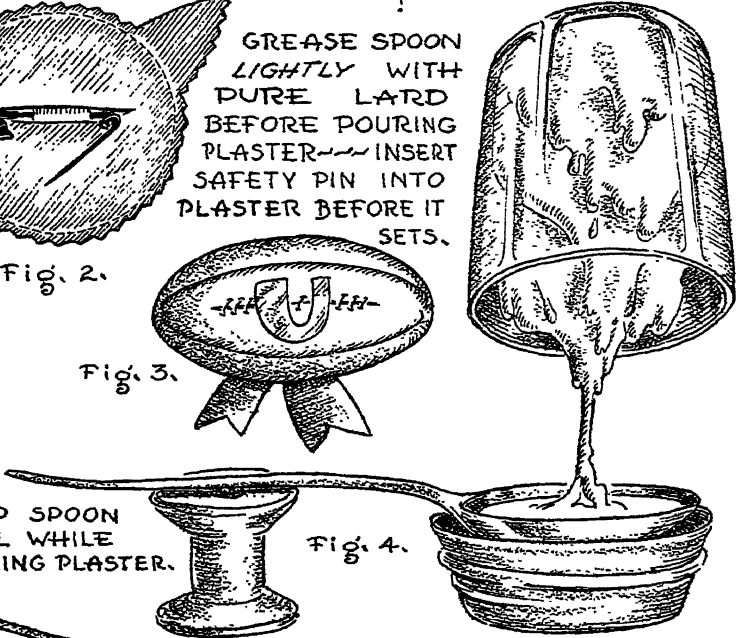

$\frac{1}{4}$ T-SPOON

Fig. 6.

T-SPOON Fig. 5.

Plate 53

can or glass jar; then using a tea strainer, sift dry plaster into the water until it barely covers the water. Mix the plaster slowly with a stick until it is just thick enough to pour easily. Pour the plaster into the greased spoon and let it stand for a few moments. Then insert an open safety pin as shown in Figures 2 and 5. Let the plaster harden for about one hour, and remove it by tapping the edge of the spoon gently on a table.

4. Scratch the design into the plaster of Paris while it is still soft and damp. Let it dry for one or two hours more. Color the design with water colors and when dry, apply two or three coats of clear nail polish or spar varnish.
5. Cut ears for the animal character in one piece with the felt backing. Use pinking shears if available, and slit the felt where the pin will emerge. Attach the felt with glue or rubber cement (Figs. 1 and 2).

Earrings

1. Earrings are made in the same manner as the lapel pins. Insert the screw attachment from an old earring instead of a pin, and paint as desired (Fig. 6).
2. Figure 3 shows a monogram cut from metal foil and forced with the fingers into the bowl of the spoon before pouring the plaster. Faces cut from a snapshot instead of a monogram will be interesting on both lapel pins or earrings. They too should be forced, or shaped into the bowl of the spoon before pouring the plaster of Paris.

DOLL HATS

MATERIALS

Straw or Felt Hats: Ladies' brightly colored, black or white straw or felt hats for the doll hats in Plate 54.

Veils, Feathers, and Decorations: Any of the various ornaments used to adorn ladies' hats have possibilities. Bright veils, small flowers, feathers, and jeweled ornaments will be especially attractive (Figs. 1 and 2).

String or Ribbon Ties: Narrow ribbons or straw braid unraveled from a large picture hat will fill the need for ties and bows (Fig. 5).

DOLL HATS

MADE FROM
CROWN TOPS FROM LADIES'
DISCARDED STRAW HATS &
THEIR TRIMMINGS OF VEILS,
FLOWERS, FEATHERS, BOWS
AND OTHER ORNAMENTS.

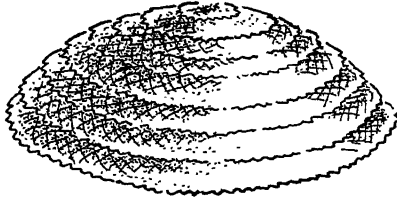
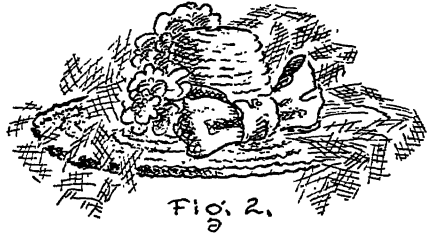

CROWN TOP OF STRAW
HAT - SOAKED IN WATER
AND MOLDED OVER A
THIMBLE - LET DRY AND
FASTEN TRIMMINGS WITH
PINS OR A
STAPLING
MACHINE.

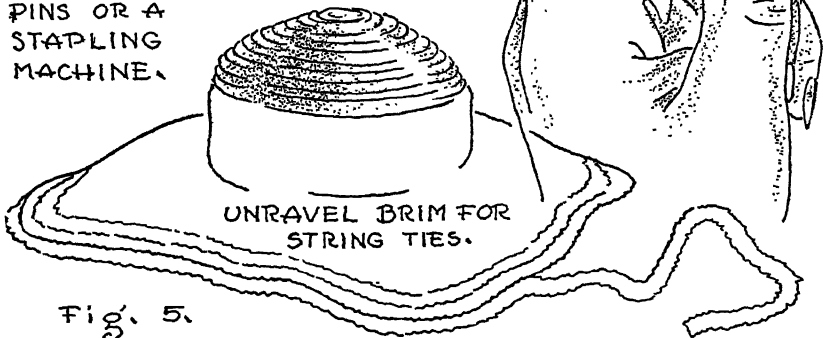

Plate 54

Hatpins: Although hatpins are not necessary, corsage pins with right pearl heads or colored beads on a pin will add sparkle to the decoration of a doll hat (Fig. 1).

Other Materials: Cleaning fluid or an artist's eraser, enamel if the color is to be changed, and clear shellac if the straw is old.

TOOLS

Razor blade, pins, needle and thread or a stapling machine to attach the decorations to the hat, pan and water to soak the straw, and a thimble or spool to be used in shaping a small crown.

PROCEDURE

Straw Hats

With a razor blade or scissors, remove all ornaments from the straw hat and cut off the top of the crown to a size suitable for a chosen doll. Refresh the straw with cleaning fluid if necessary, or apply a coat of colored enamel. Clean straw may need an application of clear shellac for stiffening.

If a crown hat is desired, soak the straw in cool water and form the crown over a thimble or spool, while wet. Tie a string at the base of the crown to hold it in shape until dry (Fig. 4). Then proceed with enamels or shellac as directed above.

Select a veil, feathers, small flowers, or other ornamentation, and attach them to the hat with pins, a stapling machine, or needle and thread (Figs. 1 and 2). Note the molding or shaping of the brim in Figure 1. Experiment by folding and rolling the brim before adding the decorations. Bright-colored veiling will add greatly to the grown-up appearance in a doll's hat.

Figure 5 illustrates the large, picture straw hat from which yards of straw braid can be salvaged. Unravel the braid with a razor blade. If the braid is narrow, it possibly can be ripped by hand. Use the braid for ties, ribbons, and bows. It is also attractive for tying gift packages.

Felt Hats

Felt hats can be treated in the same manner as straw hats, with the exception of the enamel or shellac finish. Wash soiled felt in cool, soft water and soap, or brush with cleaning fluid. Use pinking shears to cut felt whenever possible.

LIFE-OF-THE-PARTY HATS

MATERIALS

Paper Picnic Plates: Paper picnic plates to use as a foundation for a party hat (Plate 55) are available in various sizes, shapes, and designs at variety stores and grocery stores.

Paper Picnic Cups: Paper picnic cups, malted milk cups, or ice cream cups can be saved at home or purchased in food stores (Figs. 1, 2, and 4).

Paper Napkins, Broom Straws, and Bottle Caps: Paper napkins of all designs and colors will be found in the home. Straws from an old broom will add interest. Attach bottle caps to the paper napkin band for color and sparkle (Fig. 1).

Feathers, Cranberries, Popcorn, and Color Crayons: Crayon designs can be made on the hat brim and cranberries or wooden beads to dress up the crown. Sew popcorn or potato chips to the edge of the brim for bangles (Figs. 1 and 2). Colored yarns, fish cord, and carpet wark can be used for string ties as pictured in Figure 4.

TOOLS

A pencil to trace the cutout illustrated in Figure 3; pointed scissors to cut the opening in the paper plate; needle and thread to string berries or popcorn; and a stapling machine, if available.

PROCEDURE

The making of party hats from paper plates and ice cream cups will prove an exciting game for both children and adults, when done at the table before refreshments are served. Or they can be made beforehand to be distributed before refreshment time.

As a game, distribute paper plates, paper cups, a pencil, and scissors to each guest. Place all usable decorations and tools available on a table. Give a prize for the most original creation and another for the most humorous. This game is especially good for a group of art students on any grade level.

Instruct the participants to use their pencils and trace around the

LIFE-OF-THE-PARTY HATS

made from

PAPER PLATES & ICE CREAM CUPS

DECORATED WITH PAPER NAPKINS, BROOM STRAWS, POPCORN, CRANBERRIES, NECK-TIES, FEATHERS, CRAYONS, ETC.

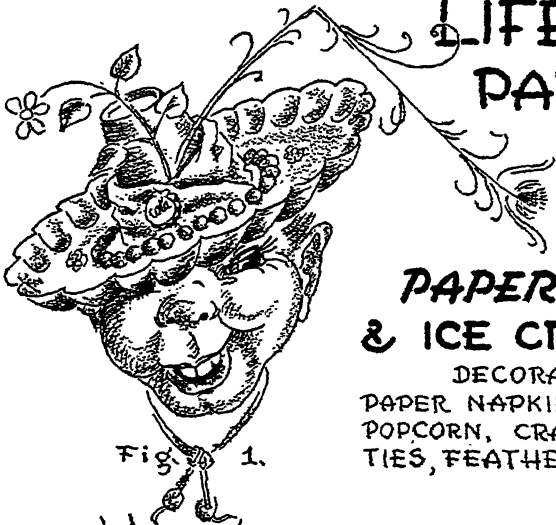

Fig. 1.

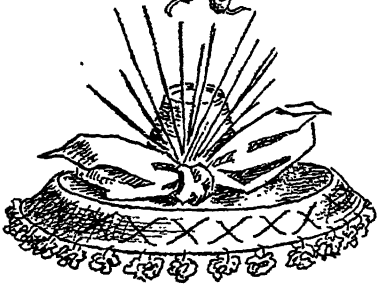

Fig. 2.

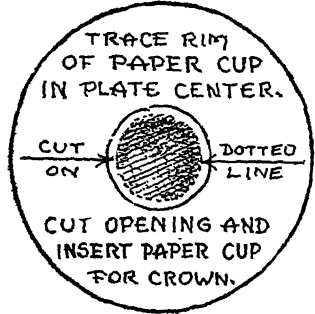

Fig. 3.

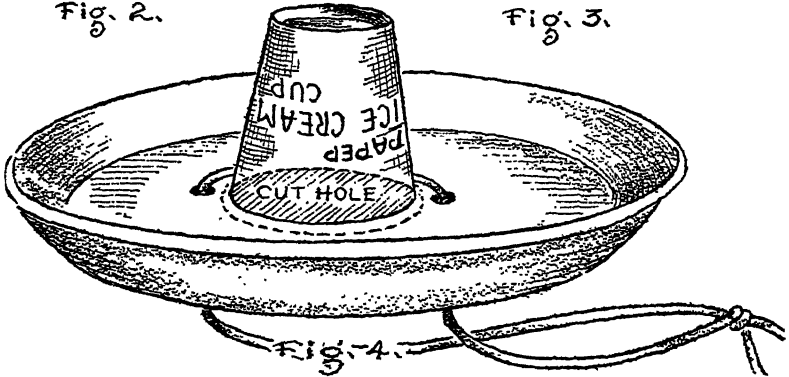

Fig. 4.

rim of the paper cup in the center of the plate. The opening is cut out with scissors and the paper cup for a crown is inserted (Fig. 4). From there on, the party guests are on their own. The plate will serve as the hat brim and may be used with brim turned up or down as desired (Figs. 1 and 2).

Holes for string ties can be punched with the pencil as indicated in Figure 4, and bottle caps can be attached to the paper napkin by removing the small inner cork, placing the metal cap against the napkin, and forcing the cork back into the cap again, with the paper between.

These party hats should be made spontaneously. Planned decorations lack the sparkle and festive spirit of the game.

PAINTED STONE PAPERWEIGHT AND BLOCK PRINTS

MATERIALS

Stone: Smooth, round, flat or irregular stones of any color and about the size of the palm of the hand (Plate 56, Fig. 1). A lake shore is the best source.

Felt: Scraps of bright-colored felt salvaged from ladies' discarded felt hats.

Paints: Colored enamels, nail polish, car touch-up lacquer, or any new commercial product.

Cloth: Any plain white or light colored cloth. Silks, rayons, linen, or cotton may be block printed. The amount of material will depend upon its use. New materials must be laundered before applying the designs (Fig. 6).

Fabric Dye: Any thick fabric dye which is advertised as permanent. A good textile paint will prove desirable.

Other Materials: Glue or rubber cement to attach the felt to the stone; clear shellac, spar varnish, or nail polish will bring out the natural color of the stone; spoon to smooth the paint over the pad; artgum eraser, potato, or carrot on which the design will be carved; paper and pencil to develop the design; carbon paper for tracing; and wrapping paper to use under the cloth to protect ironing board or table top.

TOOLS

Small brush; scissors, preferably pinking shears, to trim the felt; shallow dish or can lid; sharp pocketknife or razor blade for carving the design into an eraser or potato; and a strip of clean white cloth on which to lay the dye as a printing pad.

PROCEDURE

Painted Stone Paperweight

Thoroughly wash the stone selected for the paperweight (Figs. 1 and 2). When dry, develop an original design on the stone with enamels, car touch-up lacquer, or nail polish. Stripes, plaids, and abstract designs are most effective, although small natural scenes and monograms are adaptable to this article (Figs. 1 and 2). When the design is dry, give the stone one to four coats of clear nail polish, shellac, or varnish. Then apply a piece of bright-colored felt to the base of the stone with glue or rubber cement. Trim the felt edges as illustrated.

Block Print

1. Wash and iron the cloth selected for block printing.
2. Cut a potato in half or use a new artgum eraser, place it on paper, and trace around the edge. Develop any desired solid motif in the outlined area (Fig. 3). Then transfer this design to the eraser or potato with carbon paper as shown in Figure 5.
3. With a sharp pocketknife or razor blade, carve away the background surrounding the design. Slant the cutting tool away from the design as illustrated in Figure 4, leaving a beveled edge. The finished design with the background cut away is demonstrated in Figure 5.
4. Fold a clean white cloth into about four thicknesses and place it on a shallow dish or can lid. Pour about a teaspoon of color over the cloth and spread it smooth. Lay the fabric to be decorated over one or more thicknesses of wrapping paper, press the eraser design into the dye, and transfer the print into the fabric with a slight pressure. Continue this process to make a border design or an all-over pattern as preferred.
5. Let the dye dry overnight and press with a damp cloth on the back side of the fabric.

PAINTED 'STONE' PAPER WEIGHT

MADE FROM STONES, ENAMEL OR NAIL POLISH & FELT.

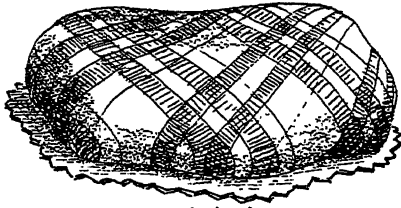

Fig. 1.
ENAMELED SMOOTH STONE.

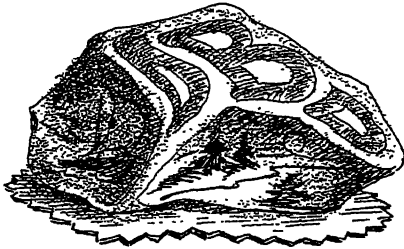

Fig. 2.
ENAMEL ON IRREGULAR STONE.

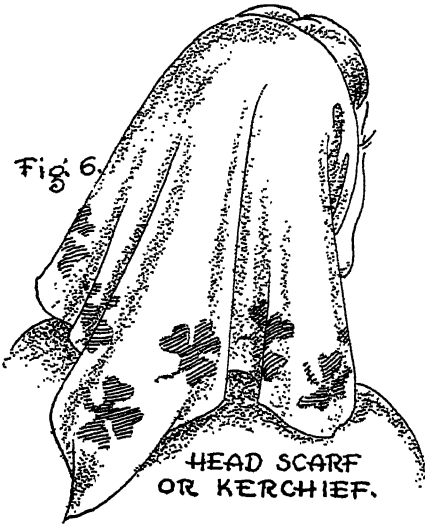

Fig. 6.

HEAD SCARF
OR KERCHIEF.

BLOCK PRINT

MADE WITH
ART GUM ERASER, POTATO
OR CARROT & FABRIC DYE.

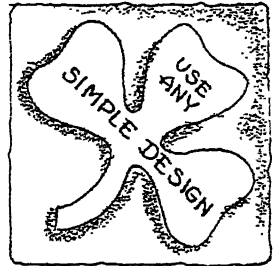

Fig. 3.



Fig. 4.

CARVE THICK BEVEL
ON DESIGN EDGE.

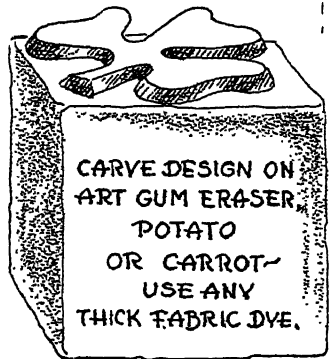

Fig. 5.

CARVE DESIGN ON
ART GUM ERASER,
POTATO
OR CARROT
USE ANY
THICK FABRIC DYE.

A RECORD CRAFT

MATERIALS

Phonograph Records: Old and worn disk records without cracks and nicks (Plate 57). The cylinder type and the new plastic disk type cannot be used.

Potted Plant: A house plant is needed if a flowerpot is to be made from a record.

Pictures: You can use photographs or colored pictures cut from magazines or calendars.

Paints: Gold bronze, enamels, and clear spar varnish. Do not use shellac.

Additional Materials: Grocer's twine, glue or rubber cement, and heavy fancy cord.

TOOLS

A deep dishpan, a tin can and very hot water, nail and a large spoon with a long handle, small paint brush, and small drill.

PROCEDURE

Flowerpot, Fruit Bowl, and Bonbon Dish

1. After deciding which of the articles in Figures 3, 4, or 5 is to be made, fill a tin can of the desired size with water and place it in a deep pan. The larger the can, the shallower the bowl will be. Fill the pan to a point above the tin can and set it on the stove to heat (Fig. 1). Bring the water only to the boiling point; do not let the water boil.
2. Tie a length of string to a nail and insert the free end of the string through the hole in the record. Lower the record over the tin can into the hot water. In a moment or two the record will sag down over the edge of the can (Fig. 1).
3. With a large, long handled spoon, mold a ruffled effect into the sagging portion of the record, shaping the record into a fruit bowl, bonbon dish, or flowerpot, depending upon the diameter of the can used (Figs. 3, 4, and 5).

Fig. 5.

A RECORD CRAFT

Make A FLOWER POT, FRUIT BOWL,
BONBON DISH, OR A PICTURE
FOR NURSERY OR PLAYROOM.

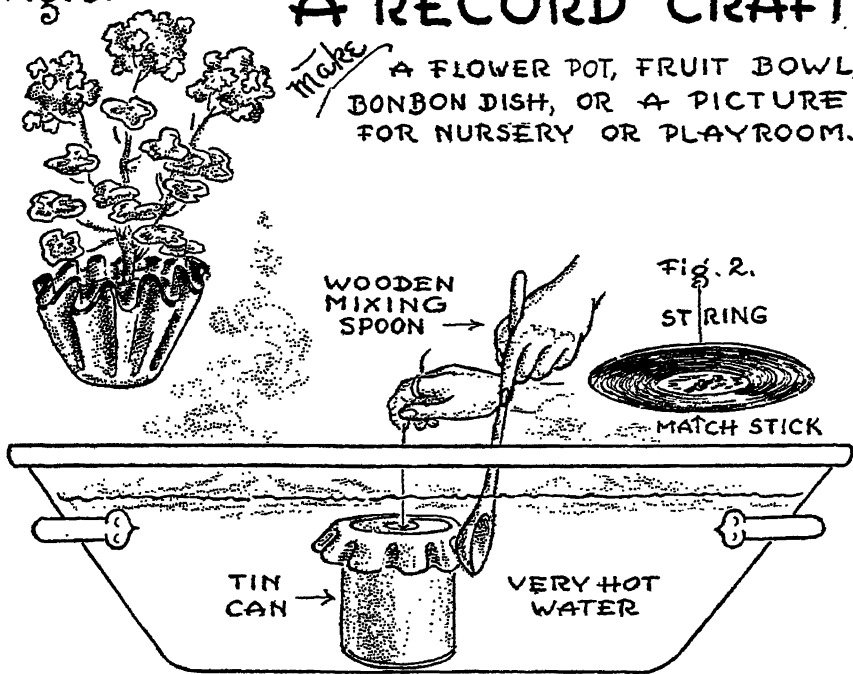

Fig. 1.

Fig. 3.

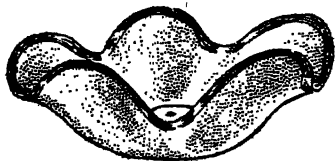

Fig. 4.



Fig. 6.



MOUNTED PICTURE
from MAGAZINE COVER

4. Remove the newly shaped record from the water and plunge it immediately into cold water to stiffen it.
5. For a flowerpot, only a coat of clear varnish on the outer surface is necessary, although it may be painted any color with enamels or gold bronze may be applied.

Use a smaller can and a bolder ruffled effect for the bonbon dish. Fill the hole with a cork and shave it smooth on both sides. Paint the entire dish with aluminum bronze (Fig. 3).

A gallon can should be used for the fruit bowl, with a finer ruffled effect molded into the rim. Fill the hole with a cork, shave it smooth on both sides, and paint with enamels, silver or gold bronze, or leave the bowl black. If the fruit bowl is to be left black, cut a colored fruit or flower picture from a magazine and apply it in the bowl to conceal the hole. Use glue or rubber cement and apply one or more coats of clear varnish.

6. Cut a circle of felt to fit the bottom of either of the dishes shown in Figures 3 and 4.

Mounted Picture

1. Figure 6 shows an old record used for a picture to hang in the playroom, the nursery, music room, etc. Mix gold bronze, place a record on the phonograph, and hold a brush dipped in the bronze against the solid black border while the record turns. A sharp, gold border can be painted on the record in this manner without moving the brush.
2. Mount a colored picture from a magazine or calendar on both sides of the record and cover the entire surface with one or more coats of clear varnish.
3. Bore two small holes near the edge at the top of the record and lace a fancy cord through them for hanging. Reverse the picture occasionally for variety.

HANDMADE CHRISTMAS CARDS

MATERIALS

Wrapping Paper and Greeting Cards: Clean, white or tinted wrapping paper, a piece about 12 by 18 in. for each card in Plate 58. Also used or unused colored metallic gift wrapping papers and metallic paper from greeting cards.

Ribbons and Cords: The narrow ribbons from candy boxes and gift wrapping cords, and colored plastic lacing or colored fish cords.

Paints: A box of water colors and a coffee can for water.

Other Materials: Paper, paste, and sugar in a shaker.

TOOLS

Ruler, razor blade, paper punch, scissors, ordinary paint brush about 1 in. wide, coarse pocket comb, and a dinner plate.

PROCEDURE

Card in Figure 1

1. Lay a piece of new, plain white or tinted wrapping paper on a smooth table top. Dip the paintbrush into a coffee can of water. Prepare and soak the water colors by brushing lightly over all of the colors in the paint box.
2. When colors have soaked sufficiently, with the middle of the brush pick up a color such as blue, then on one side of the brush pick up red, and on the other side, black (Figs. 2, 3, and 4).
3. Turn the brush over on a dinner plate or pie tin, and run a coarse pocket comb through the ends of the bristles.
4. Turn the brush right side up again and brush quickly across the paper in stripes or a plaid design. Start the brushing movement off the paper, ending off the opposite edge. Cover the paper in this manner. Change the colors and design for the next paper. Make as many as the number of cards desired, each with a different color combination.
5. When dry, fold the papers lengthwise and across, making a French fold; then trim with scissors while folded, to fit a specific envelope.

Handmade envelopes may be made from this same type of decorated paper, folding the painted design inside.

6. Cut a bright picture from an old Christmas card and paste it on the cover of the paper fold (Fig. 1). Cut a greeting from another used card and mount it on the inside (Fig. 5). Punch holes as illustrated in Figure 1 and lace the holes with fancy gift wrapping cords or colored yarns.
7. The right edge of Figure 1 shows an insert of gold, silver, or colored metallic paper salvaged from other greeting cards and left-over Christmas wrapping papers. The illustration on the cover may be mounted also by cutting a window in the front, smaller than the picture, and then gluing the picture back of the window.

Card in Figure 6

1. The card shown in Figure 6 should be made on plain, undecorated paper of any kind.
2. Fold the card as recommended.
3. Print and draw Christmas designs freehand with a pencil. Fill in the lettering and illustrations with bright water colors and, while still wet, shake sugar over the colors. This will add a snowy sparkle to the greeting card.

HANDMADE CHRISTMAS CARDS

made from WRAPPING PAPER - WATER COLORS - SUGAR-OLD CHRISTMAS CARDS - METALLIC CARD LININGS - LARGE BRUSH.

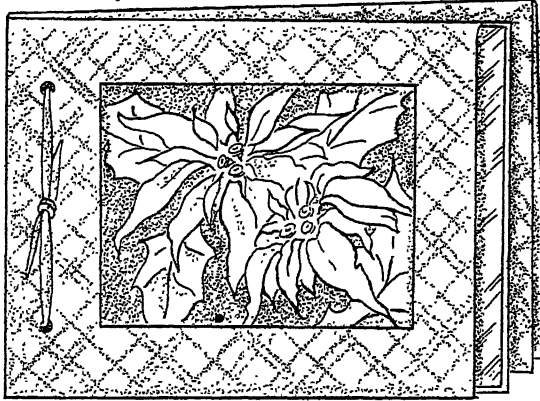

Fig. 1. CUT OPENING IN COVER & INSERT PICTURE FROM OLD CHRISTMAS CARD.

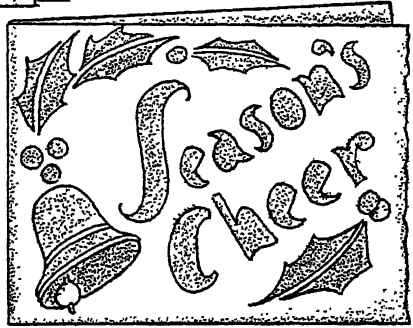
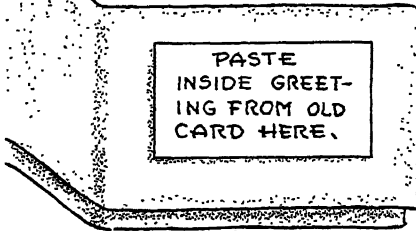

Fig. 5. Fig. 6

ALL 3 COLORS ON THE SAME BRUSH.

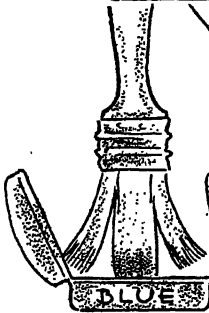

Fig. 2.



Fig. 3.

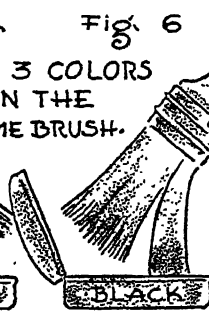

Fig. 4.



Fig. 7

USE:

WATER COLORS.

LARGE, FLAT

PAINTBRUSH.

GLUE.

PENCIL & RULER.

FUN WITH EASTER EGGS

MATERIALS

Eggs: Hard-boiled eggs — white, tan, or speckled eggs dyed any color desired or left the original color (Plate 59).

Paper Lace Doilies or Crepe Paper: The smaller, round, paper doilies, crepe paper, or colored tissue paper (Fig. 1).

Other Ornamentation and Materials: An old felt hat, metallic paper star seals, rickrack, narrow gift-wrapping tape, colored yarn, wax crayons (especially white), egg dye, red nail polish, glue or rubber cement, and narrow strips of cardboard or the plugs from a roll of wrapping paper.

TOOLS

Scissors, large paper punch, and utensil for boiling the eggs.

PROCEDURE

Easter eggs can be made in the classroom or at an Easter breakfast, the ingredients being supplied by the host. Made in advance, Easter eggs decorated as described above will serve as favors or place cards for an Easter dinner. Teachers and group leaders should stimulate the creative ability of the child by encouraging him to develop his own Easter egg designs.

Boil eggs for at least 15 minutes and allow them to cool completely.

Figure 1

Make a clown by drawing the mouth with colored crayon or red nail polish. Cut the nose, ears, and eyebrows from colored felt. Draw the eyes with crayon and use a spot of felt for the pupil. Make hair from yarn and glue it to the shell. Cut a hat from fancy paper or felt and fashion the collar with ruffled crepe paper or small, lace paper doilies. Decorate a plug from the end of a roll of wrapping paper for a standard, or use a ring of cardboard covered with crepe paper as in Figure 3. Make pompons from yarn or buttons with spots of felt.

FUN WITH EASTER EGGS

Made from FELT SCRAPS~RICKRACK~DECORATIVE TAPE
 INDIA INK~CREPE PAPER~SEALS~YARNS~CRAYONS AND
 METALLIC WRAPPING PAPER~SCISSORS~PUNCH~NAIL POLISH.

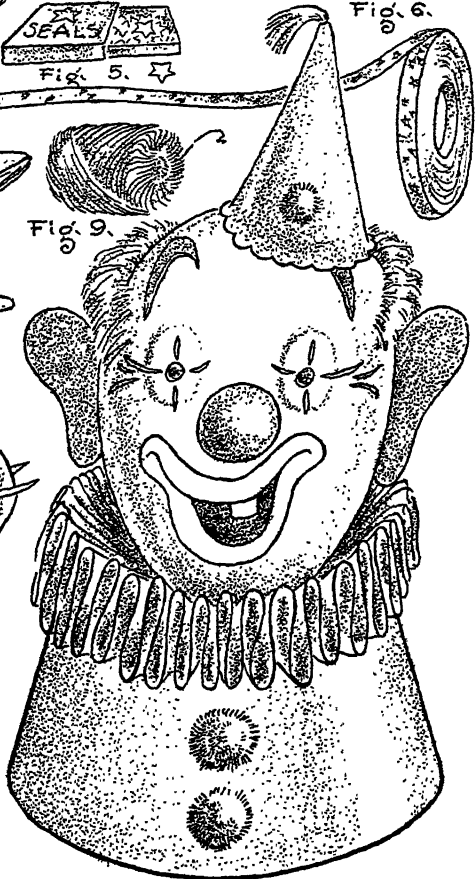
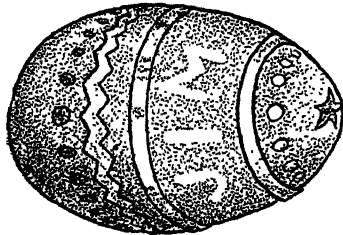
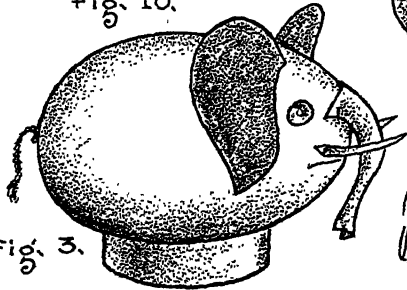
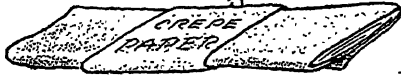
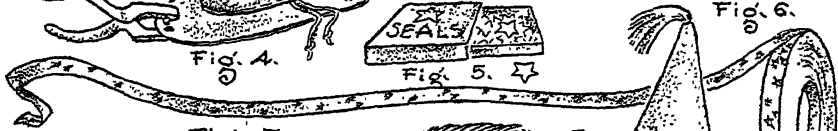

Fig. 2.

Fig. 1.

Plate 59

Figure 2

Letter the egg with white wax crayon and dip the egg into very bright or dark red dye. Let dry and then decorate the Easter egg with spots punched from an old colored felt hat, rickrack, decorative tape, and metallic star seals.

Figure 3

Make the elephant with colored felt ears, tusks, and trunk cut from colored or white felt or construction paper attached to the egg with rubber cement or glue.

The standard is a roll of cardboard covered with crepe paper. The egg is mounted on this base in place of feet for the animal. Make any kind of animal in a similar manner.

LAMP SHADE AND CABIN CURTAINS

MATERIALS

Burlap Potato or Feed Bags: The shade can be made from one single burlap bag. Cabin curtains will require several bags, depending upon the number and size of the curtains (Plate 60).

Shade, Frame, Lamp, Base, and Fixtures: Use a discarded lampshade frame or make one with coat hangers (Fig. 1): The illustration pictures a lamp base fashioned from a small hardwood pickle keg with metal bands (Fig. 2). Other objects which might be used for a base are jugs, table legs, driftwood, birch logs, cooky jars, and large fancy bottles. Salvage fixtures from a broken or discarded lamp. New wiring may be needed.

Colored Yarns and Fabric Paints: Colored yarns are ideal for embroidery work on burlap, or for inserting where threads are pulled to make a border. Rickrack and bias tape are also effective pulled into the weave for added color (Fig. 3). Fabric paints are good for decorating burlap with stencil or for freehand painting.

Other Materials: Paper for patterns, and extra heavy white paper on which to mount the burlap for a shade. Use a good laundry bleach to lighten the color and soften the texture of the burlap. Clear shellac for mounting and finishing the material on the shade.

LAMP SHADE & CABIN CURTAINS

made from

BURLAP - COLORED YARNS - COAT HANGERS - FABRIC BLEACH - A SMALL PICKLE KEG & LAMP FIXTURES.

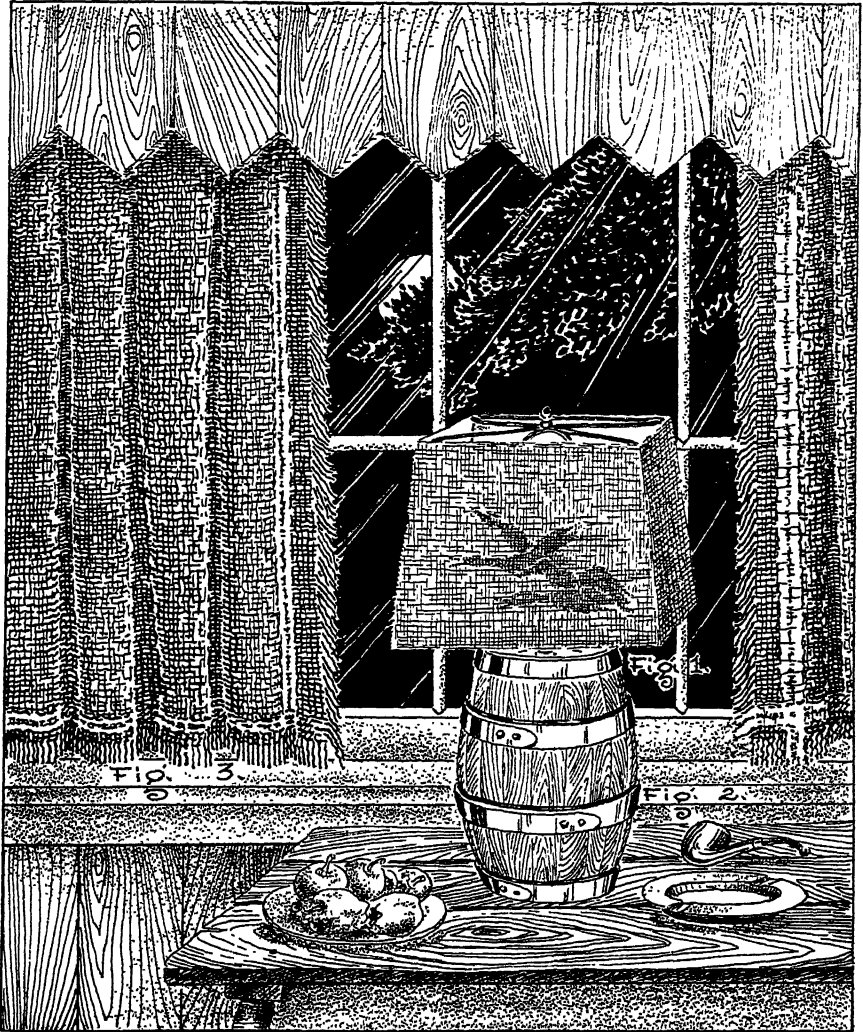

Plate 60

TOOLS

Pencil, scissors, razor blade, a darning needle, if embroidery designs are to be used, and tools such as wire cutters and screw driver for assembling the fixtures.

PROCEDURE

Lamp

1. Select an object suitable for this craft and adaptable as a base for a lamp (Fig. 2). Check to see that available electrical fixtures will fit the opening at the top of the lamp base chosen.
2. Condition the burlap (Fig. 1) as follows: If the material is soiled, wash it in a washing machine. Soak the burlap in a tub of soft water, using a half gallon of bleach for each two bags. Soak overnight, rinse, dry, and iron with a very warm iron. The result is amazing. The material will be soft and silky, light in color and texture, and easy to work.
3. Assemble the fixtures and attach them to the base.
4. Using a cast-off lamp shade for a frame, remove the covering, and use it for a pattern for the new shade. Cover the wire frame with heavy, white paper. Coat this covering with clear shellac. Using the old covering for a pattern, cut burlap to fit the frame, add another coat of shellac to the paper covering, and mount the burlap on the paper while the shellac is still wet. Allow it to dry and paint an appropriate design on the cloth with stencil and fabric paint. When the design is thoroughly dry, apply two more coats of shellac over the entire shade, allowing each coat to dry before applying another. Trim the shade with bias tape or sew the edges with yarn, using a decorative stitch.

Curtains

1. Measure the windows to determine the number of burlap bags needed.
2. Treat the raw burlap as described in step 2 above.
3. Trim the edges and decorate either with colored yarn embroidery or pull threads for a border. Insert colored yarns, rickrack, or bias tape where the threads have been pulled. Fringe the edges (Fig. 3), and pleat or hem the top for hanging.

PROFESSIONAL HELPS FOR THE CRAFTSMAN

Throughout the country the teacher, group leader, and craftsman will find supply houses that will be able adequately to furnish the tools, equipment, and materials which he needs. Current magazines and newspapers are replete with names of firms that you can contact either in person or by mail. Often catalogues can be had upon request. They are an excellent means of keeping apace with new developments, obtaining valuable helps, and restocking depleted supplies.

