

CREATIVE AWL

leather patterns

LADIES' BAG

PREPARED BY:

Patryk Ku,
www.CreativeAwl.com

LET'S GO:

01

PRINT THE PATTERN

- Open your pattern in Adobe Acrobat Reader. Set up options of your printer on A4 paper with 0 margins.
- Every page has a measure - check does it fit.
- Every printed page **MUST HAVE** a border around! If doesn't - move paper left/ right and print again

02

FOLLOW VIDEO INSTRUCTIONS

Video tutorial:

<https://youtu.be/cbrtUSfa650>

Cutting patterns:

https://youtu.be/2TNUI_TIk64

03

GIVE A SMILE TO OTHER PEOPLE!

Give a ready product to you family or freind. Give them a smile :)))

Also Check www.CreativeAwl.com for more patterns

JOIN OUR FB GROUP

04

Go there to share your work. Also get more DIY&ideas. We will support you & answer all questions.

<https://www.facebook.com/groups/CreativeAwlPatterns>

YOU NEED

TOOLS

- sharp knife
- 1,2-1,5mm hole puncher or pricking irons or awl
- hammer
- 2 needles
- paper tape
- a home printer

MATERIALS

- about 0,35 square meter of leather
- Waxed thread (preferable 0,8mm 0,8-1 mm)
- 2 x 20 mm d-rings
- 29 x 25(height) mm swing lock
- zipper



SHARE YOUR WORK

<https://www.facebook.com/groups/CreativeAwlPatterns>

If you got ANY problem,- don't be shy to ask directly on Etsy or facebook

-The number in the circle shows which holes are to be connected. Example: ①

-Numbers 1, 2, 3 (...) without a circle indicate where the piece lies in the overview drawing.

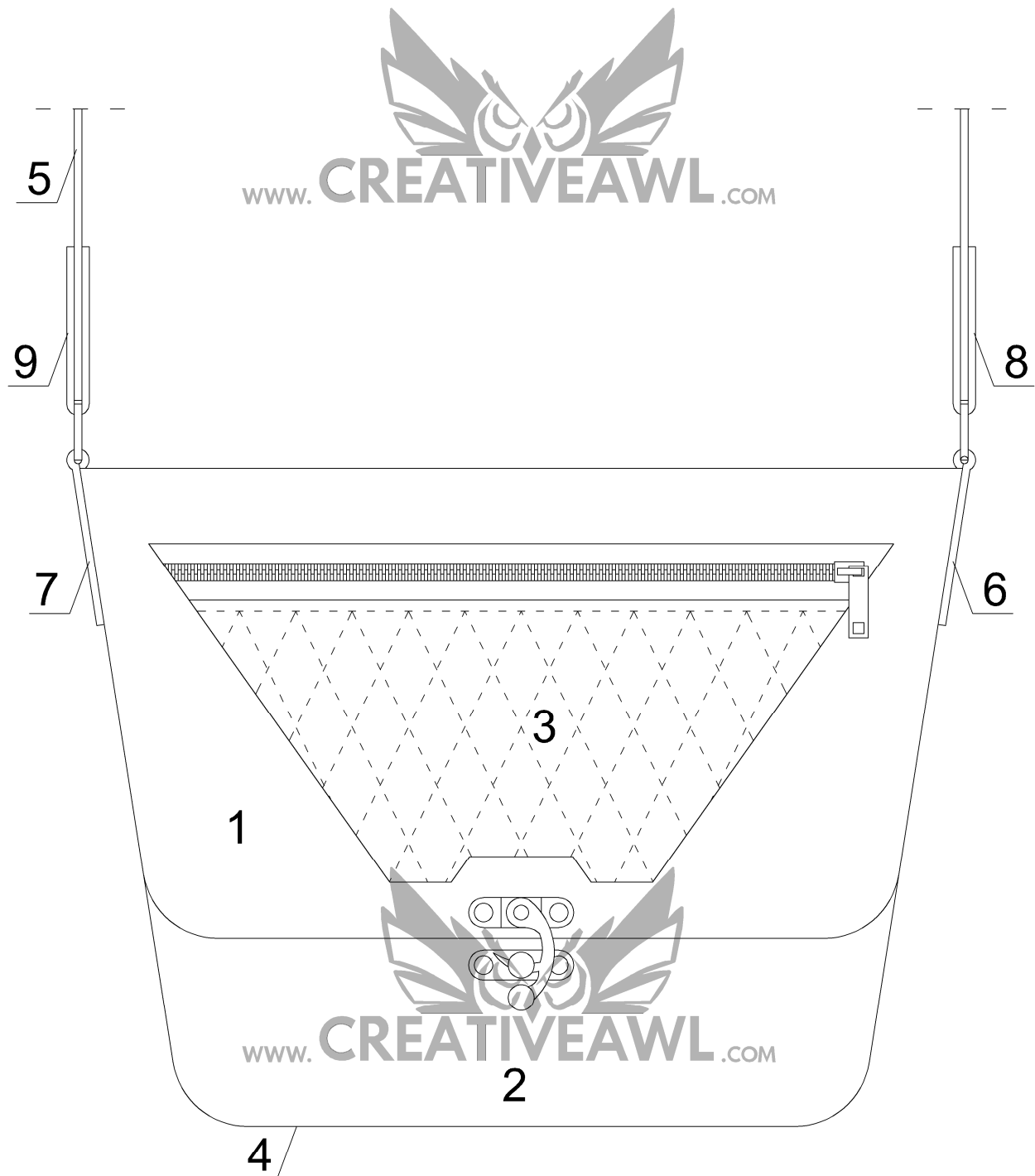

Leather needed for women's
daily bag:

350 mm (14 in)

about 0,35 m²

950 mm (38 in)

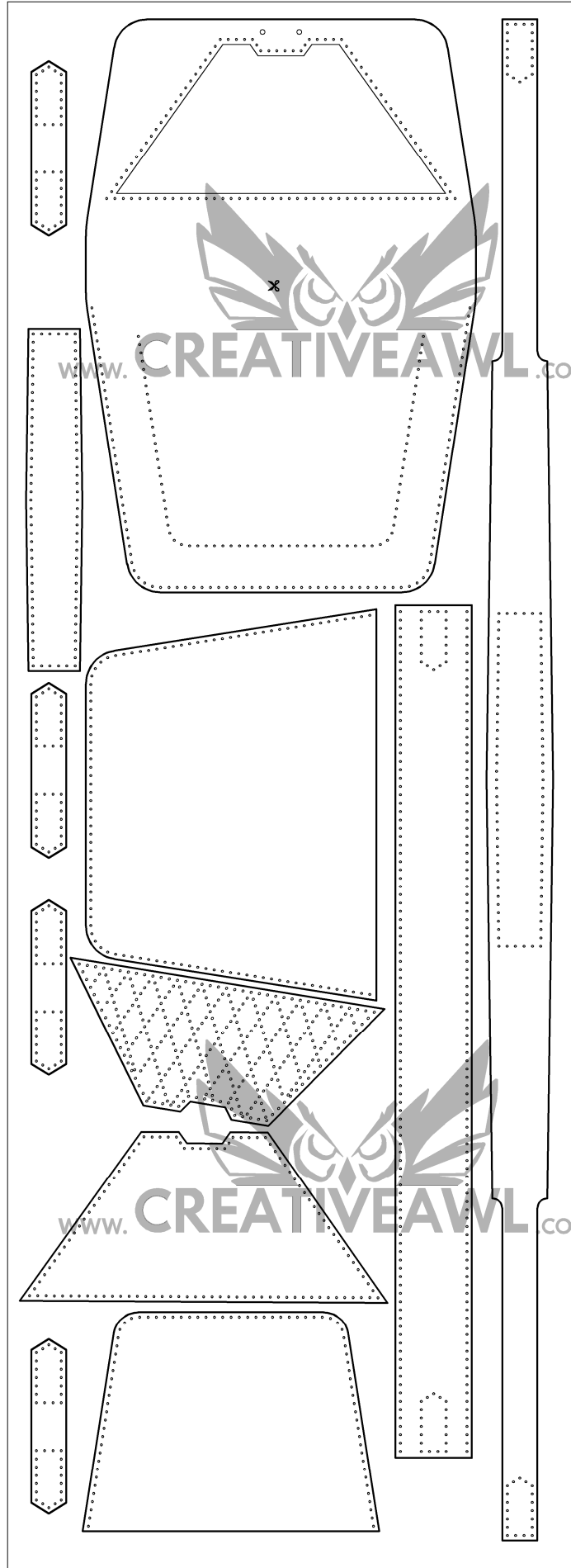

Sketch drawing
Bill of materials

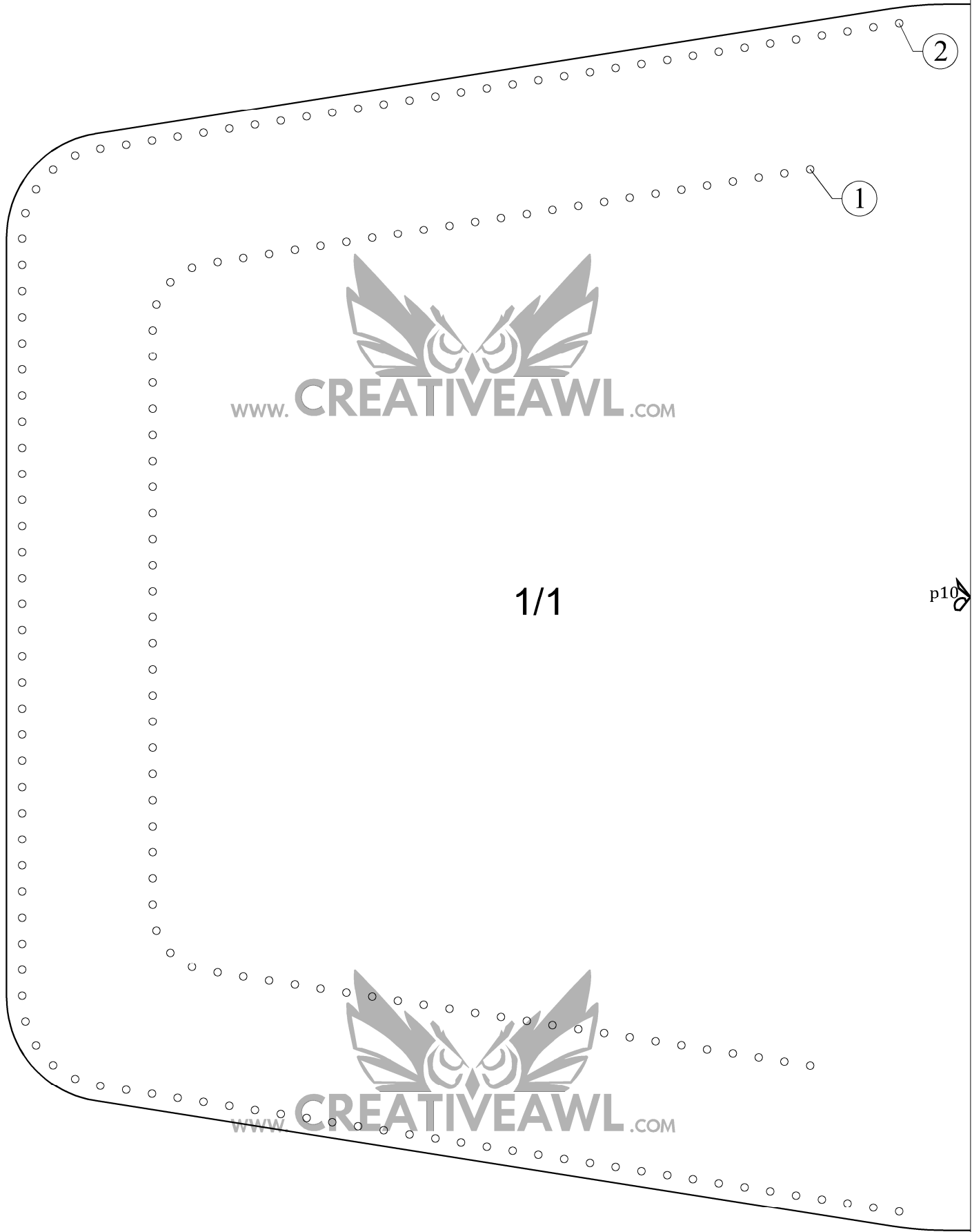

1/1

p10

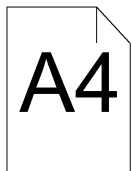
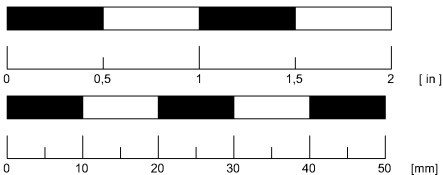

Woman's daily bag

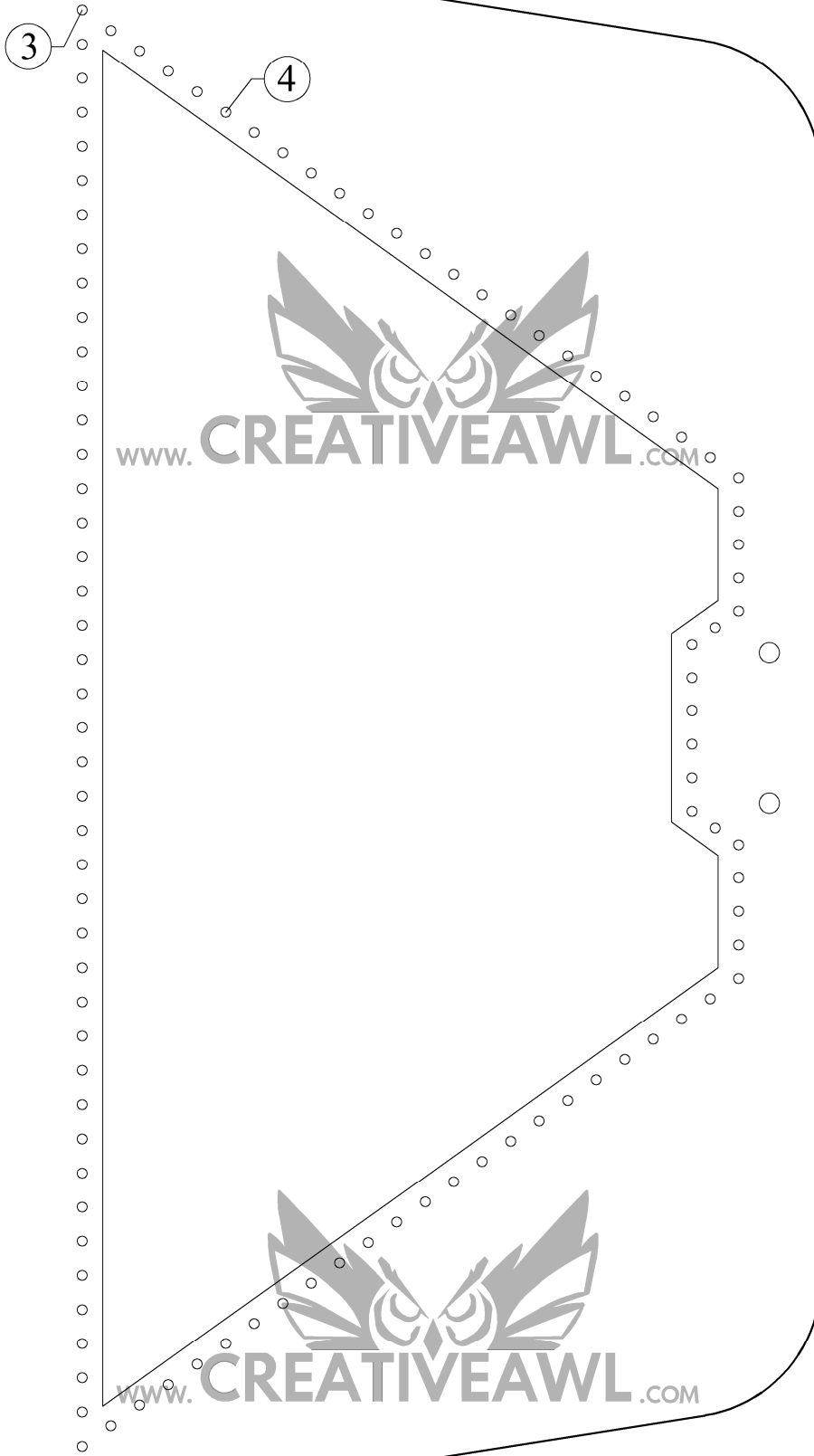

10

1/2

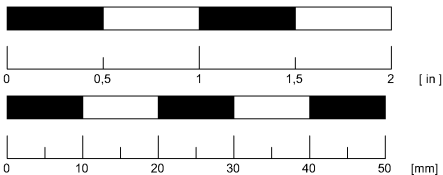

Woman's daily bag

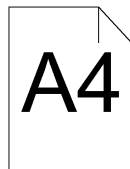
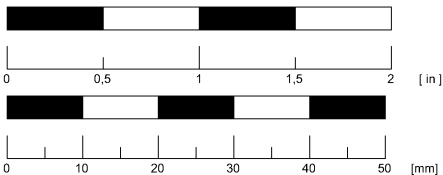
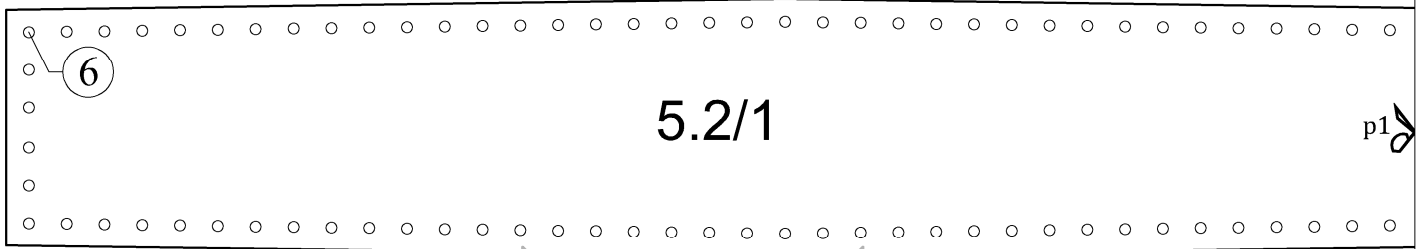

Woman's daily bag



2/1

p6

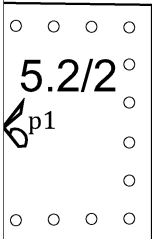

5/2

p2

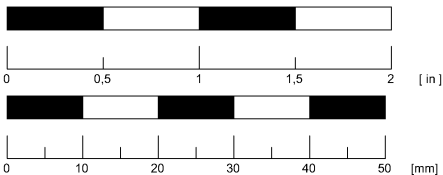
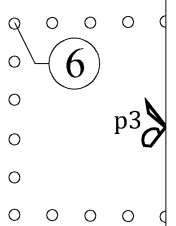

Woman's daily bag

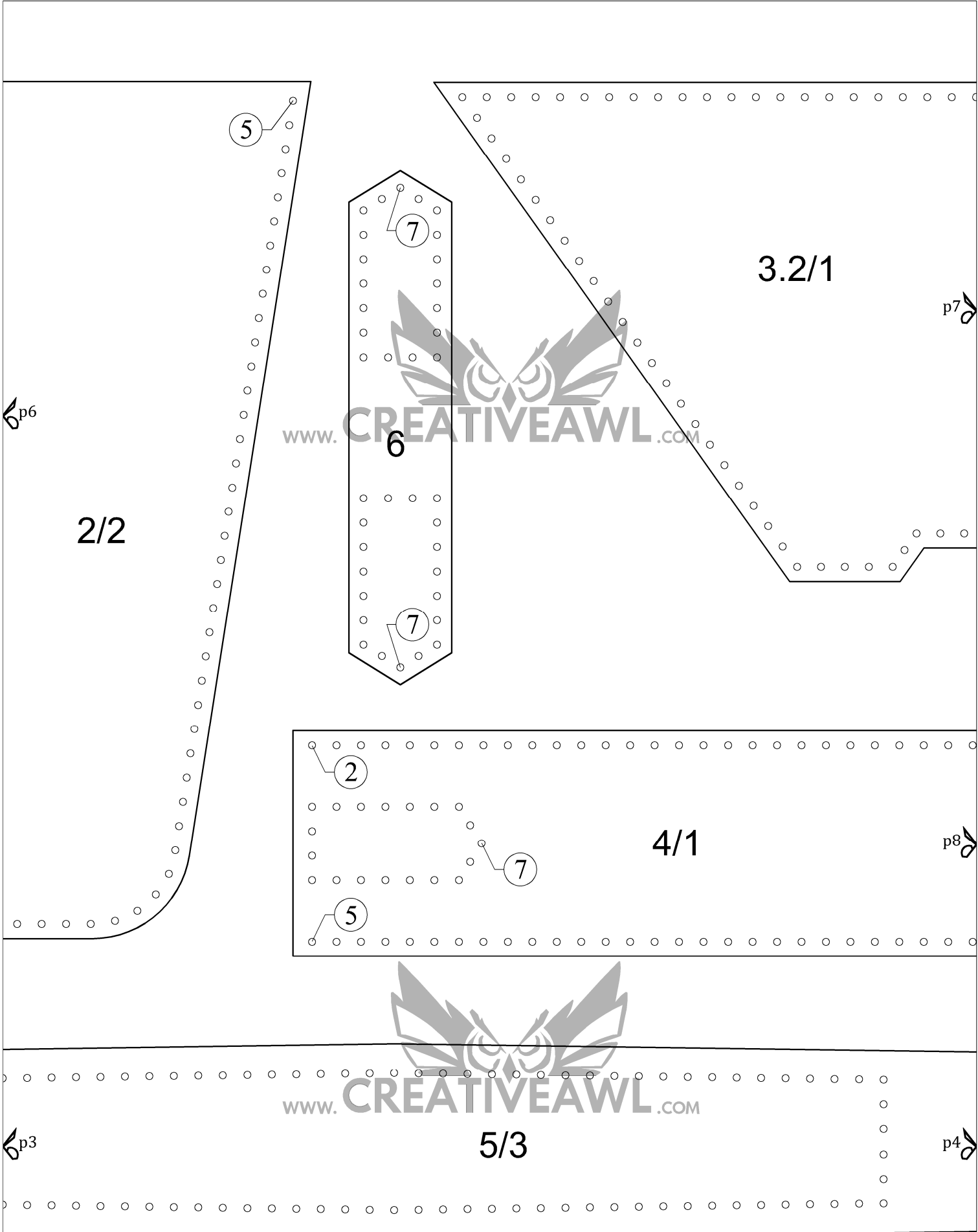

www.CREATIVEAWL.COM

www.CREATIVEAWL.COM

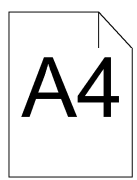
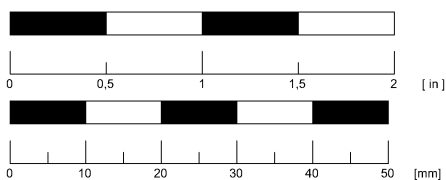

Woman's daily bag

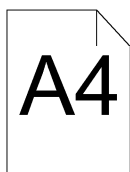
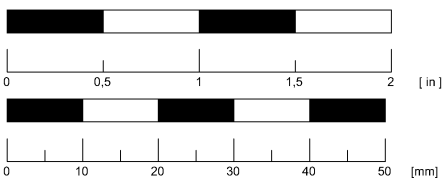
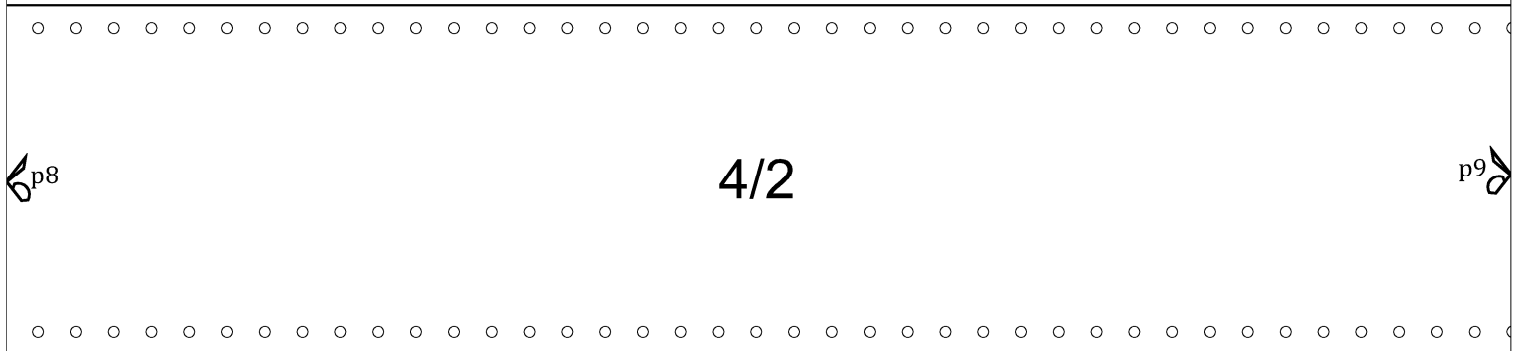
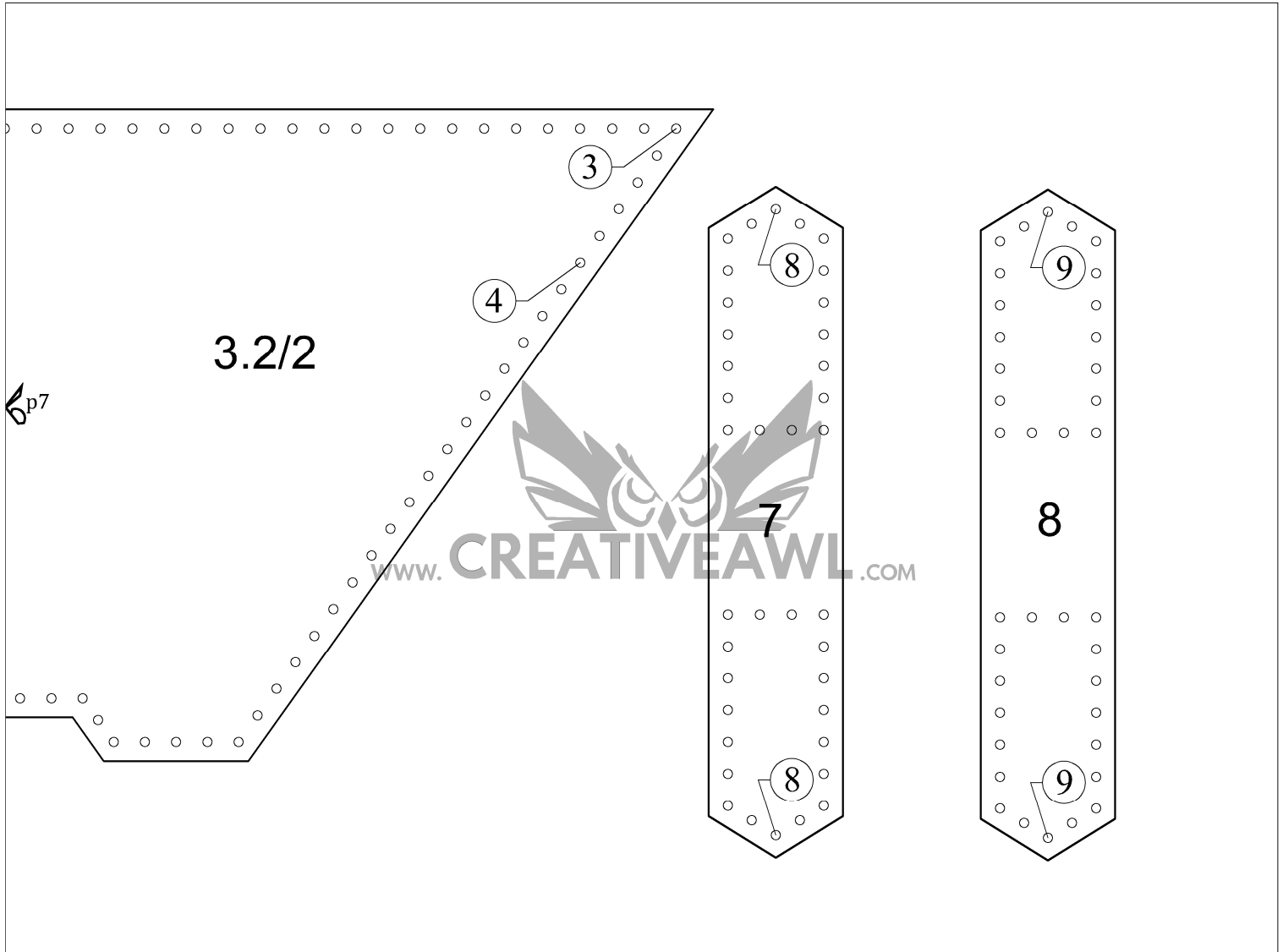

Woman's daily bag

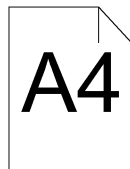
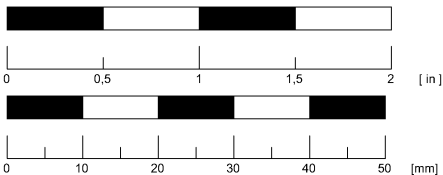
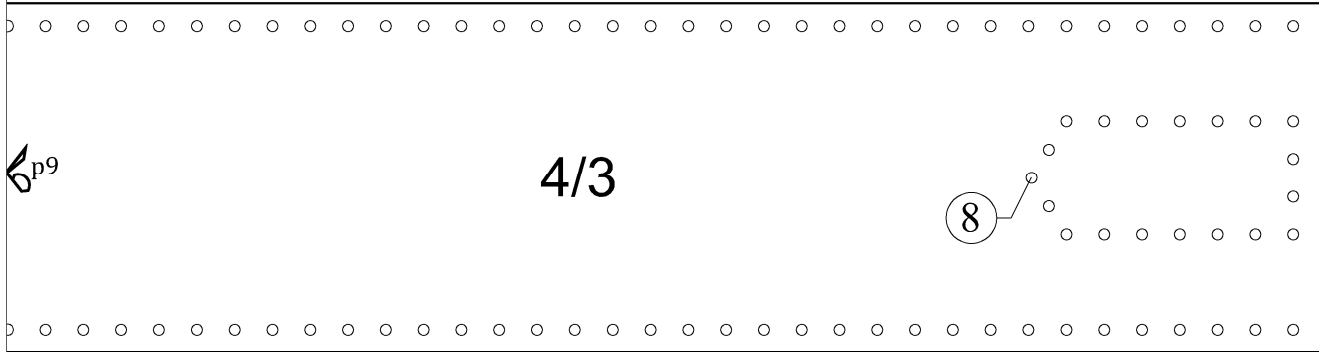
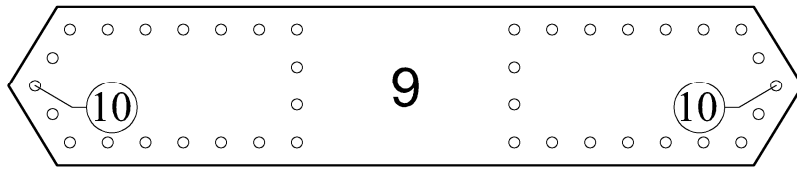
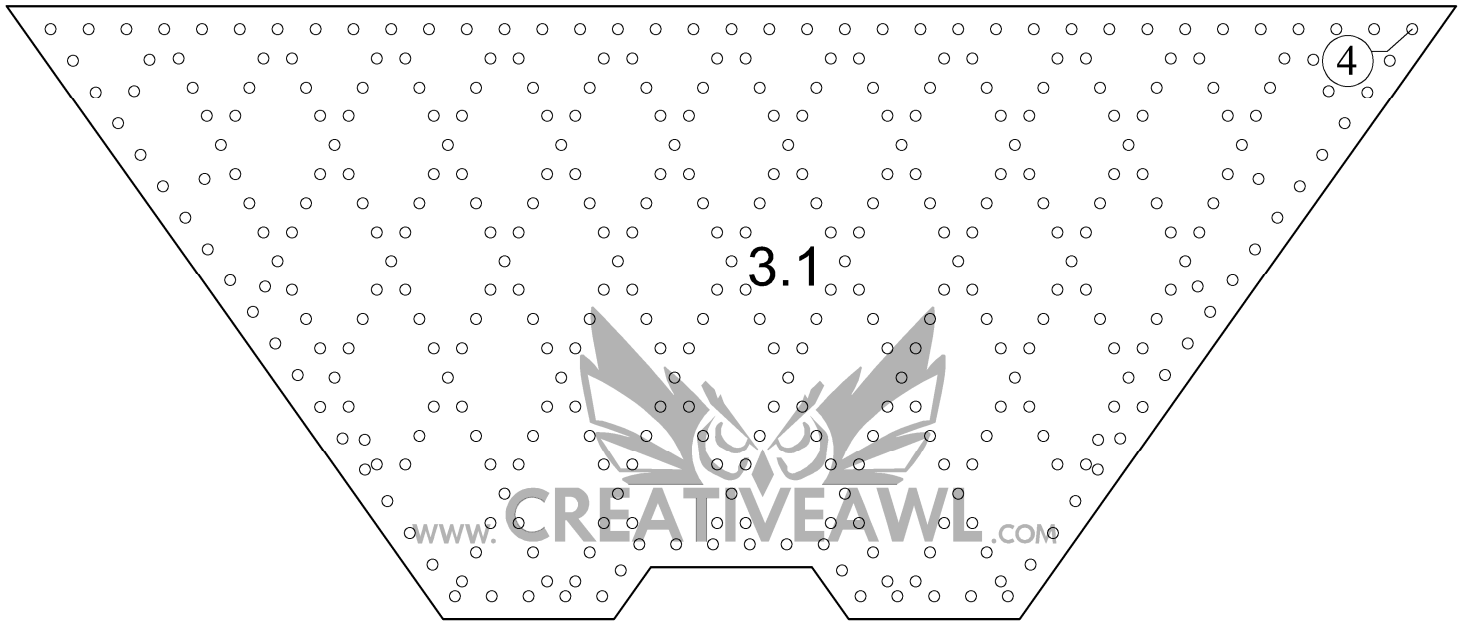

Woman's daily bag