



CREATIVE AWL

leather patterns

**ELISABETH
COSMETIC BAG**

PREPARED BY:

Patryk Ku,
www.CreativeAwl.com



**PLEASE
READ!**

If it wasn't for your support, this pattern wouldn't have come into being, thanks! If you already post pictures of your bag in the social media, I would be invariably glad if you would mention the author. I also encourage you to share your work on our facebook group.

All rights reserved. No content may be shared or reproduced. If you would like to share it, please recommend our facebook group or <https://www.creativeawl.com>

Thank you and have fun!

Patryk

LET'S GO:

01

PRINT THE PATTERN

- Open your pattern in Adobe Acrobat Reader. Set up options of your printer on A4 paper with 0 margins (if needed).
- Every page has a measure - check does it fit.
- Every printed page **MUST HAVE** a border around! If doesn't - move paper left/ right and print again and check the settings

02

VIDEO TUTORIAL:

[HTTPS://YOUTU.BE/VYPRPEBAZUG](https://youtu.be/VYPRPEBAZUG)

Cutting patterns:

https://youtu.be/2TNUI_TIk64

03

GIVE A SMILE TO OTHER PEOPLE!

Give a ready product to you family or freind. Give them a smile :)))

Also Check www.CreativeAwl.com for more patterns

04

JOIN OUR FB GROUP

Go there to share your work. Also get more DIY&ideas. We will support you & answer all questions.

<https://www.facebook.com/groups/CreativeAwlPatterns>

YOU NEED

TOOLS

- sharp knife
- 1-1,5 and 3, 4, 8, 10mm hole punchers
- hammer
- 2 needles
- paper tape
- a home printer

MATERIALS

- 3.8 sqft (0,35sqm)
preferable vegetable tanned 5 -6 oz leather
- 0,8mm waxed thread
- few rivets



SHARE YOUR WORK

<https://www.facebook.com/groups/CreativeAwlPatterns>

If you got ANY problem,- don't be shy to ask directly on
Etsy or facebook

Cosmetic bag:

pages: 5 - 15

Elliptical cosmetic bag:

pages: 16 - 28

-The number in the circle shows which holes are to be connected. Example: ①

-Numbers 1, 2, 3 (...) without a circle indicate where the piece lies in the overview drawing.

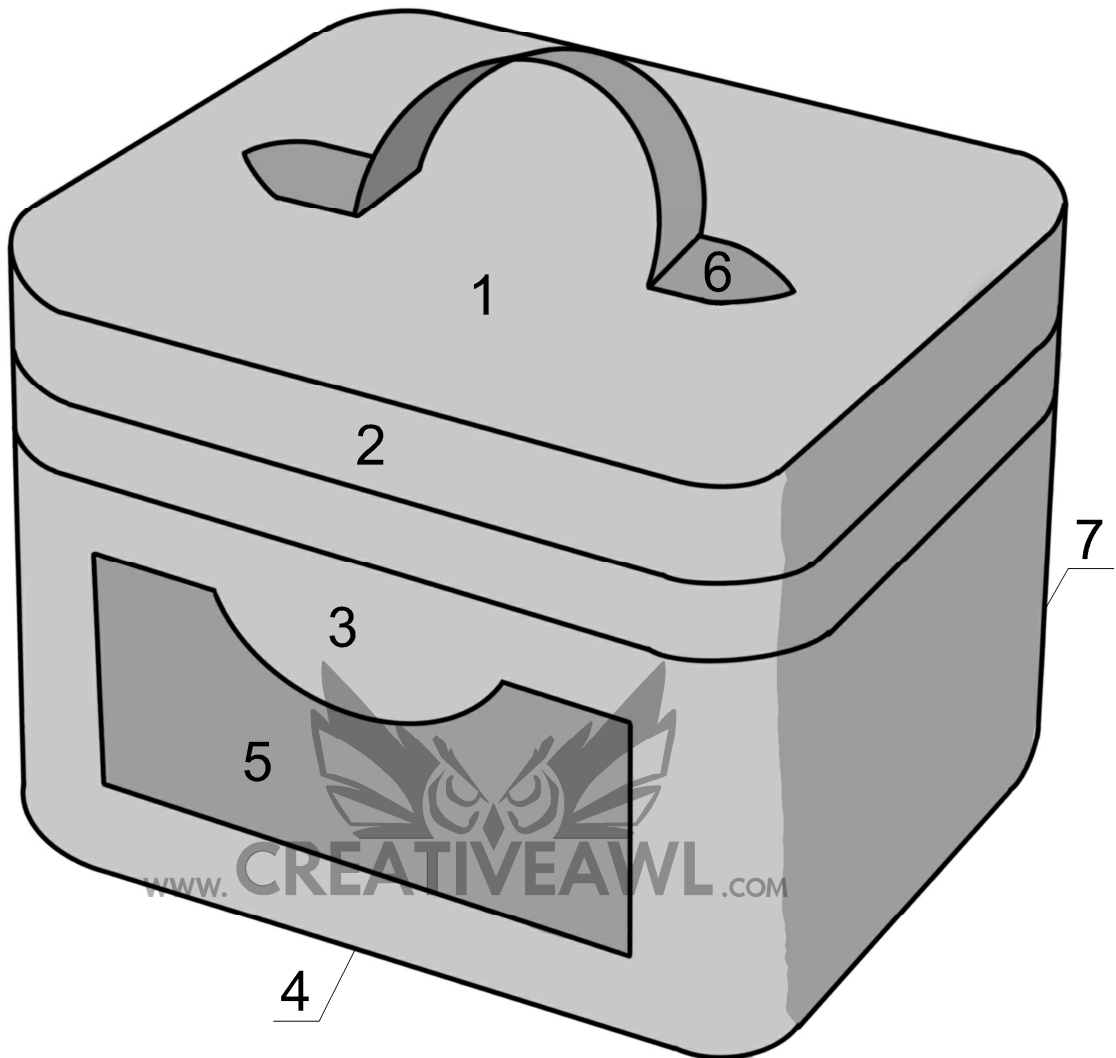

11 in
LETTER
8,5 in

A4

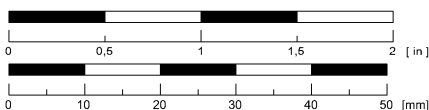

Sketch drawing

Leather needed for a Cosmetic bag:

about 0,36 m2

410 mm (16,4 in)

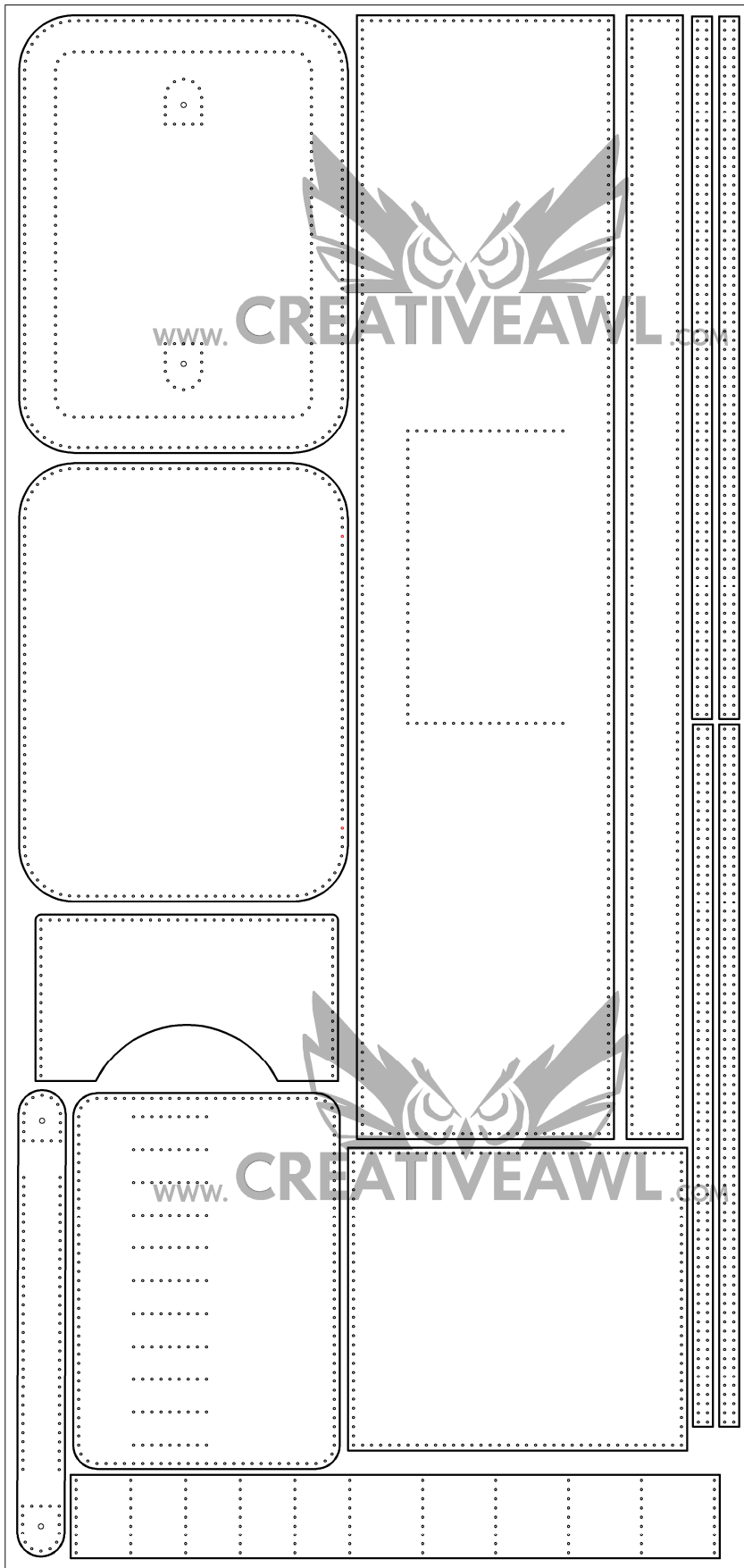

860 mm (34,4 in)

Sketch drawing
Bill of materials

7

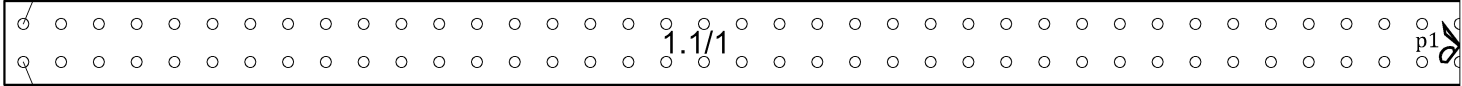

5

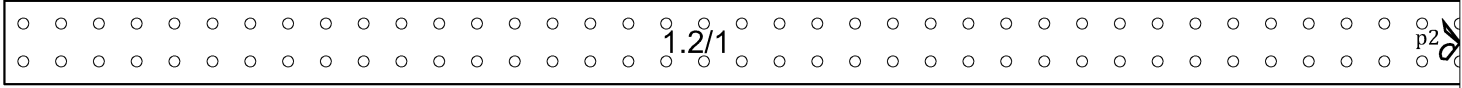

www.CREATIVEAWL.COM

2/1

p3

1

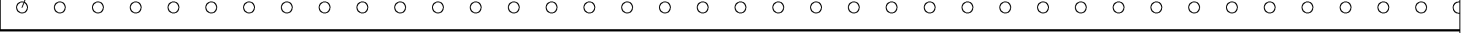

3



www.CREATIVEAWL.COM

3/1

p8

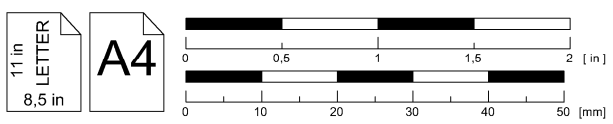

Cosmetic bag

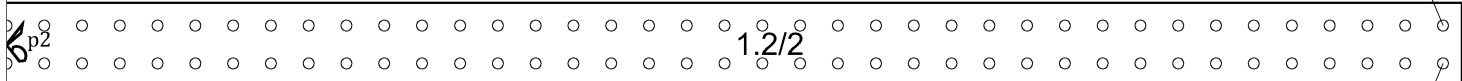
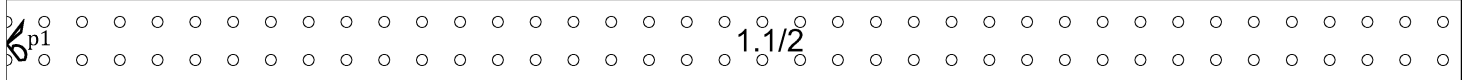

8

6



2/2

www.CREATIVEAWL.COM

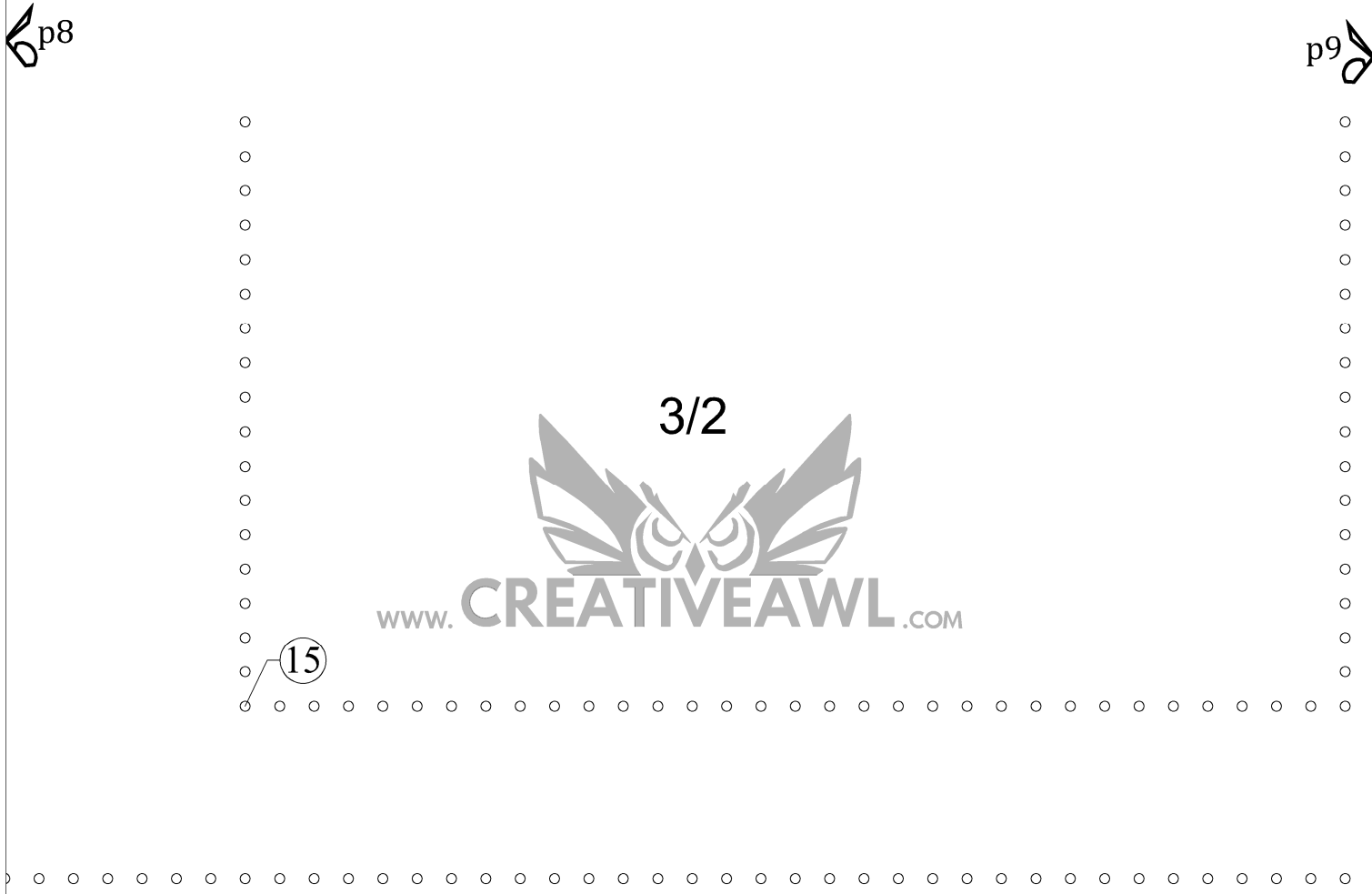

3/2

www.CREATIVEAWL.COM

15

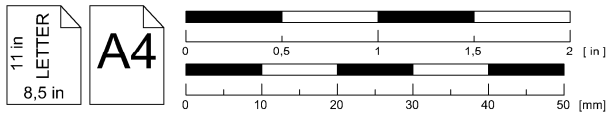

Cosmetic bag



11

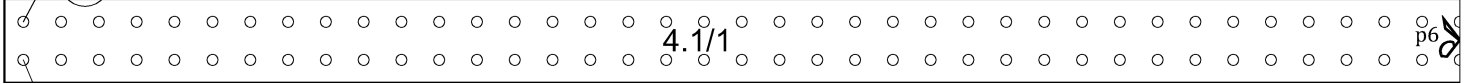

9

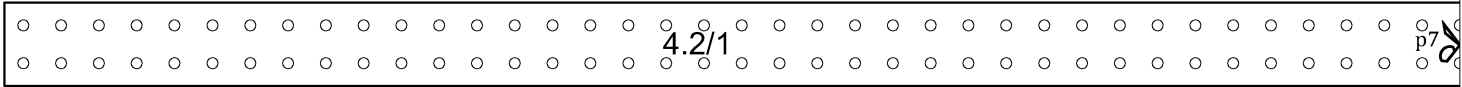

p4

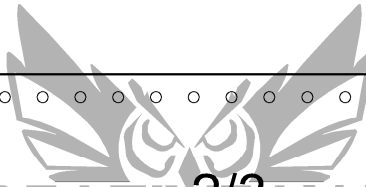

www.CREATIVEAWL.COM

2/3

p5

p9

p10

3/3



www.CREATIVEAWL.COM

11 in
LETTER
8,5 in

A4

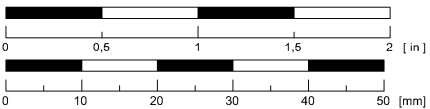

Cosmetic bag

9

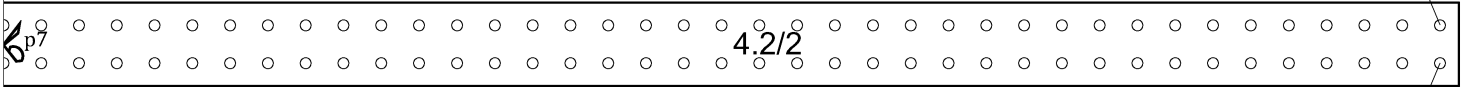

12

10

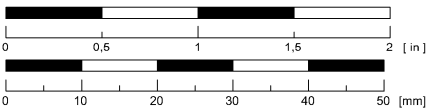
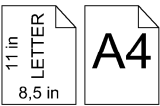
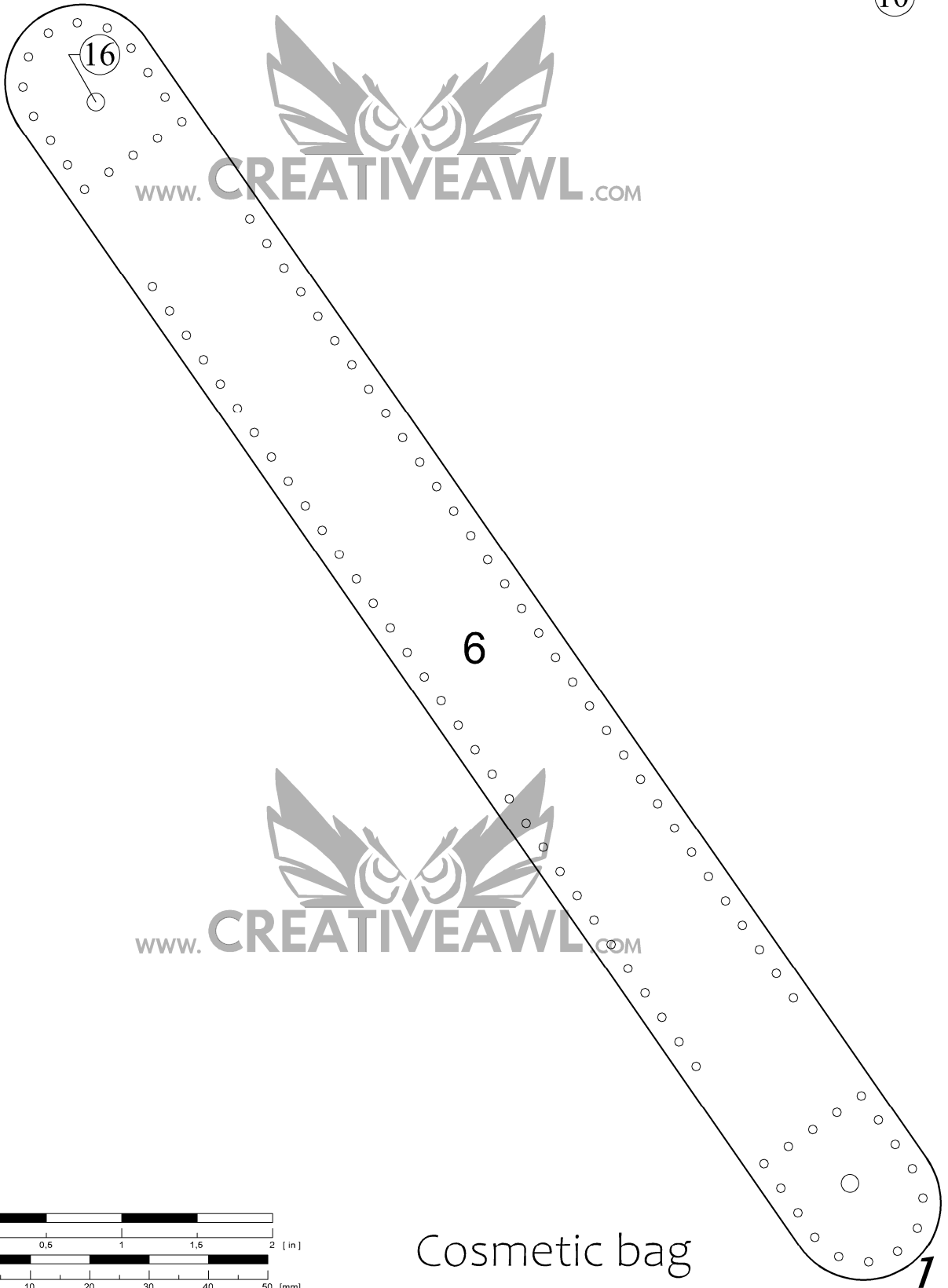
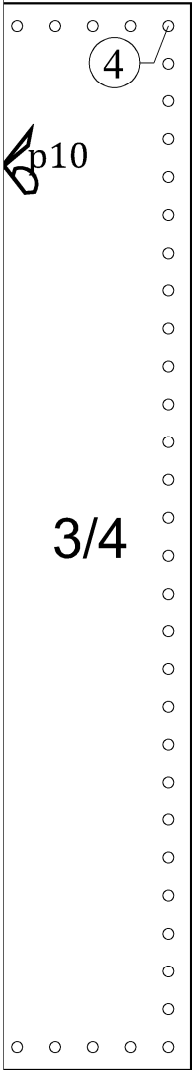
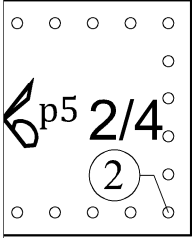

Cosmetic bag

10



1

7

8

13

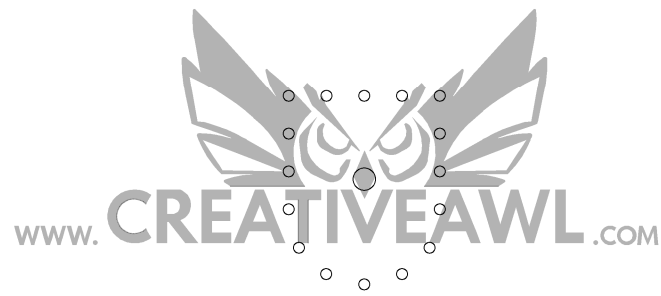

11 in
LETTER
8,5 in

A4

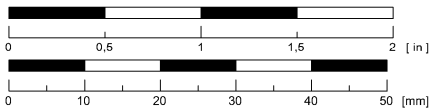

Cosmetic bag



4

11

12



11 in
LETTER
8,5 in

A4

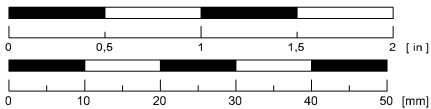

Cosmetic bag

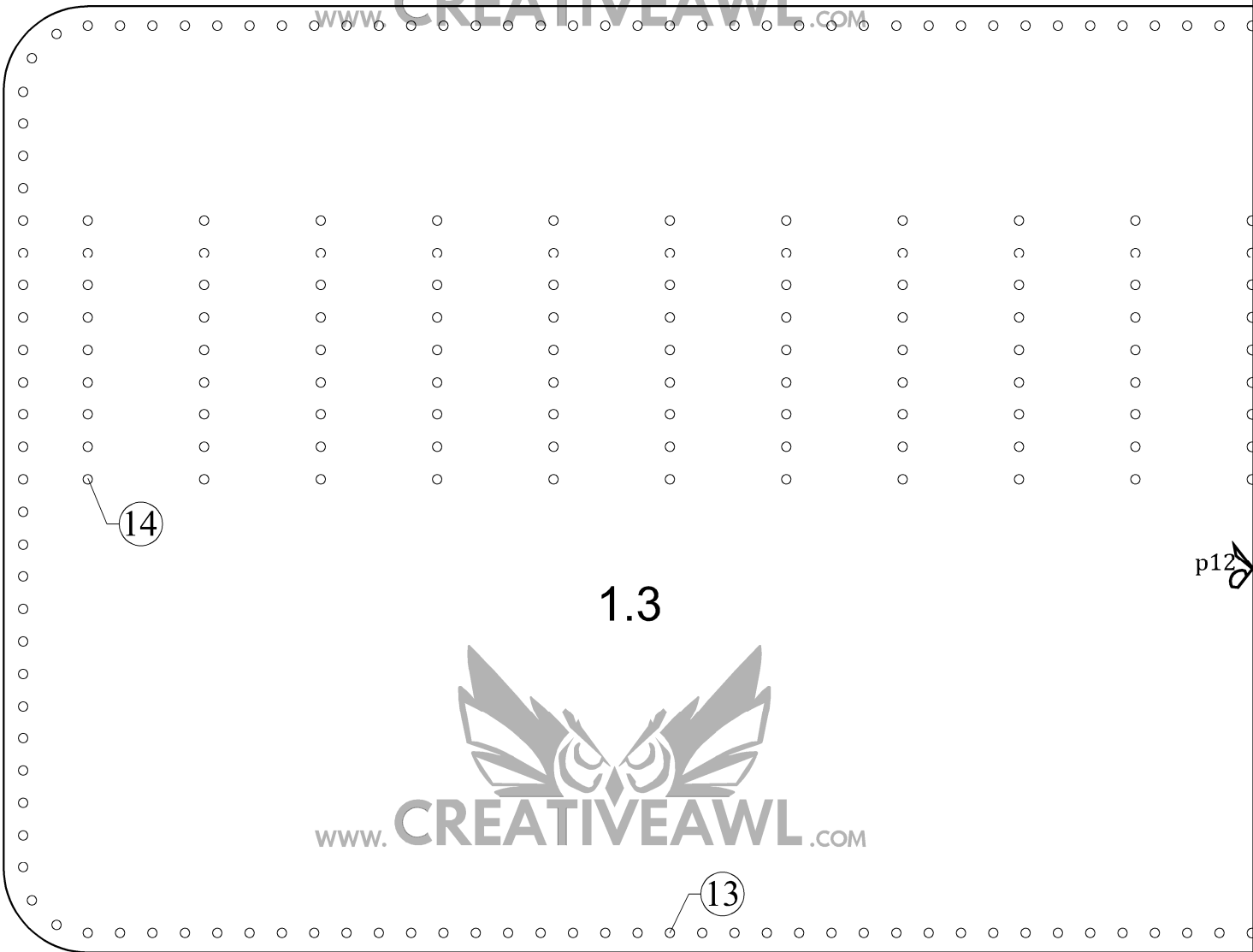
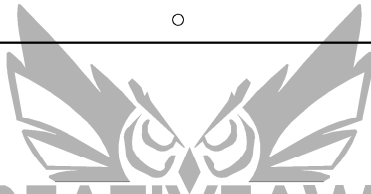
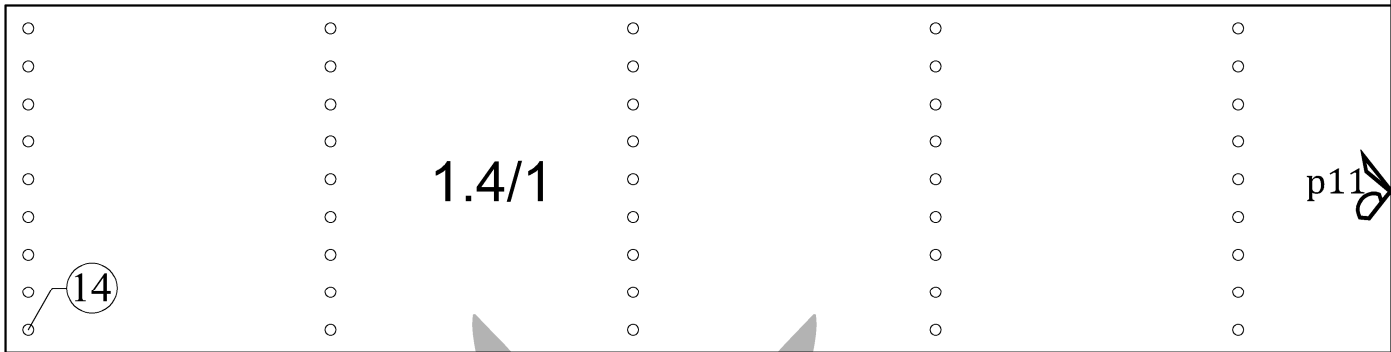

11 in
LETTER
8,5 in

A4

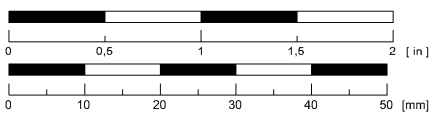

Cosmetic bag

p11

1.4/2

p12

www.CREATIVEAWL.COM

www.CREATIVEAWL.COM

7

2

4

1

3

10

9

11 in LETTER 8,5 in A4

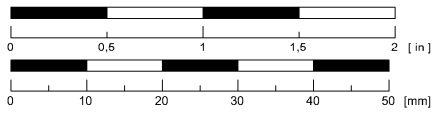

Cosmetic bag



WWW.CREATIVEAWL.COM

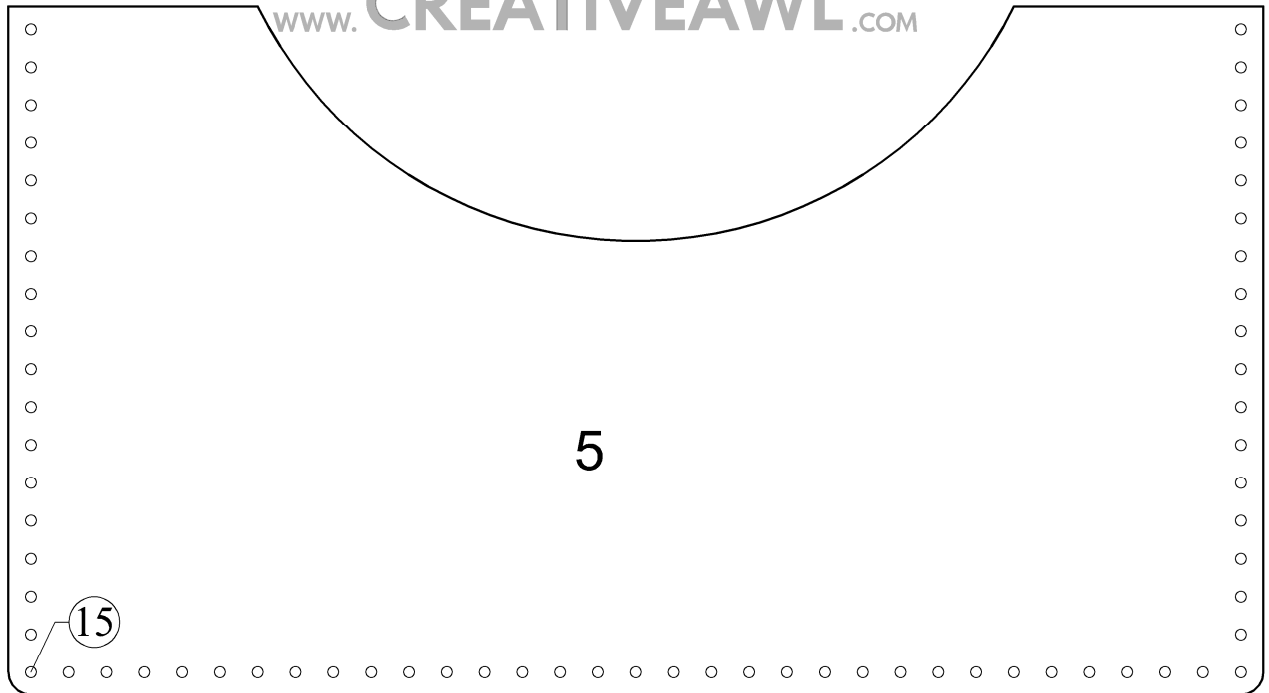

WWW.CREATIVEAWL.COM

11 in
LETTER
8,5 in

A4

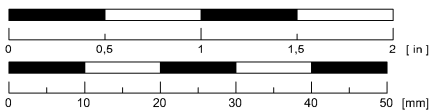

Cosmetic bag

Elliptical cosmetic bag:

pages: 16 - 28

-The number in the circle shows which holes are to be connected. Example: ①

-Numbers 1, 2, 3 (...) without a circle indicate where the piece lies in the overview drawing.

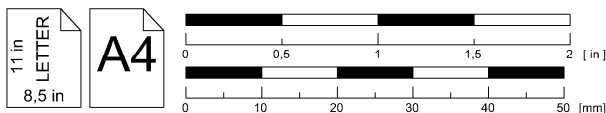
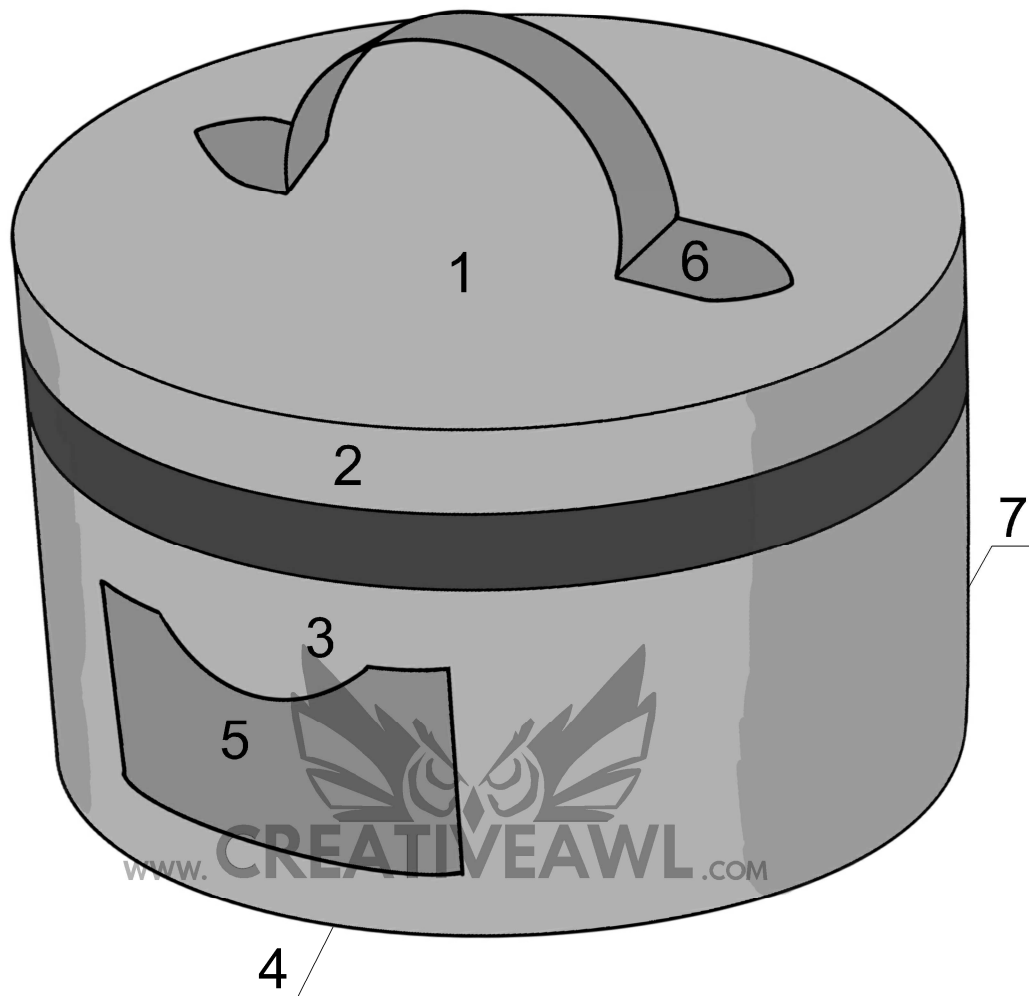

Sketch drawing

Leather needed for a elliptical
cosmetic bag:

about 0,38 m2

400 mm (16 in)

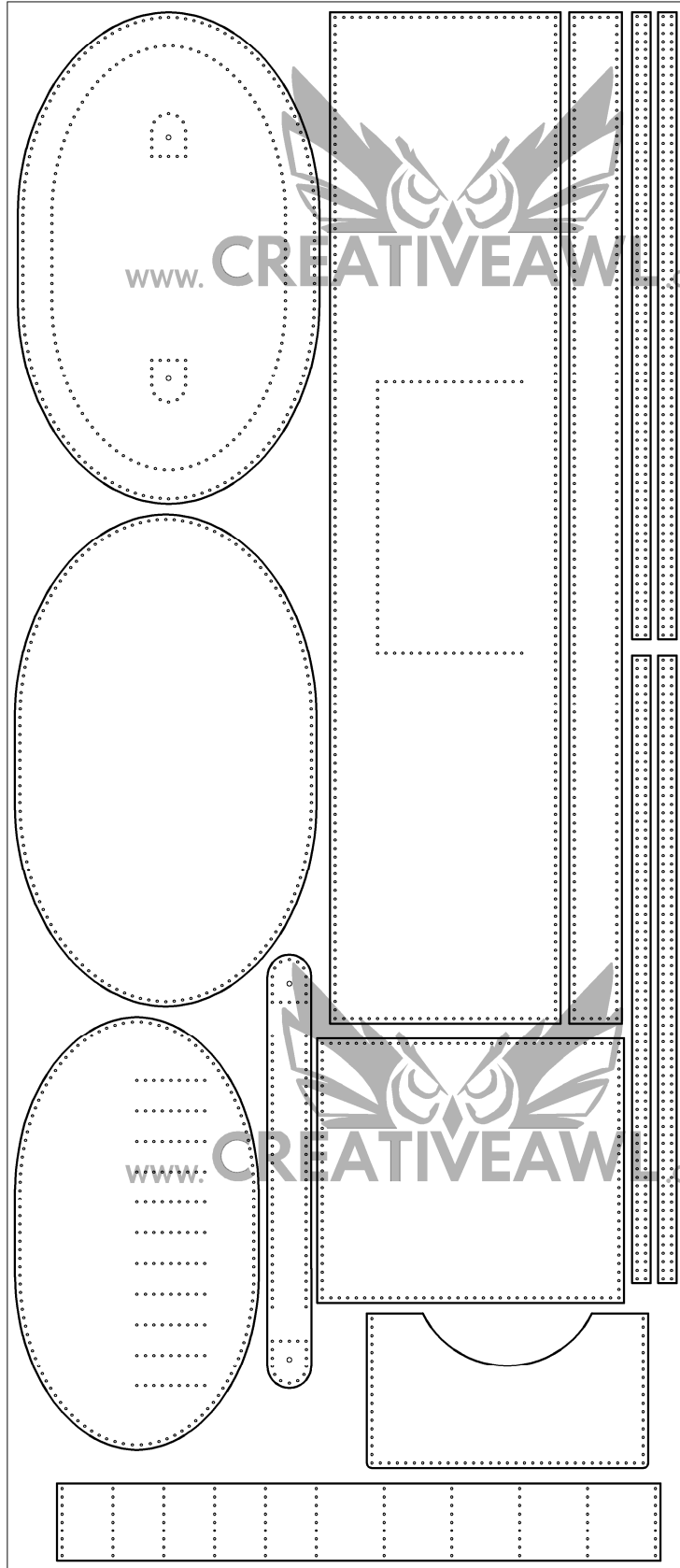

930 mm (37,2 in)

Sketch drawing
Bill of materials

7

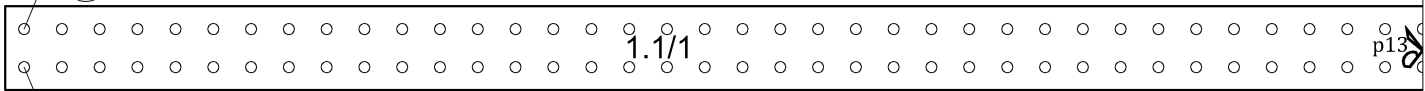

5

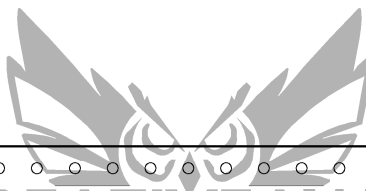
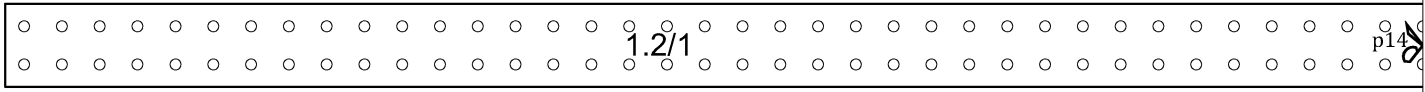

www.CREATIVEAWL.COM

2/1

p17

1

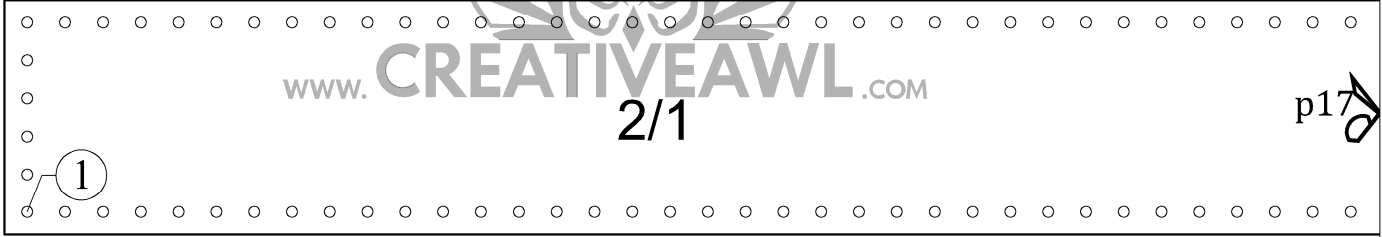

3



3/1

www.CREATIVEAWL.COM

p20

11 in
LETTER
8,5 in

A4

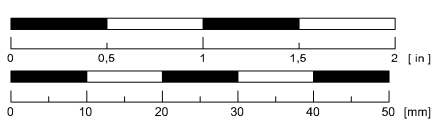

Elliptical osmetic bag

18

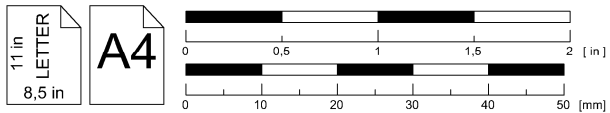
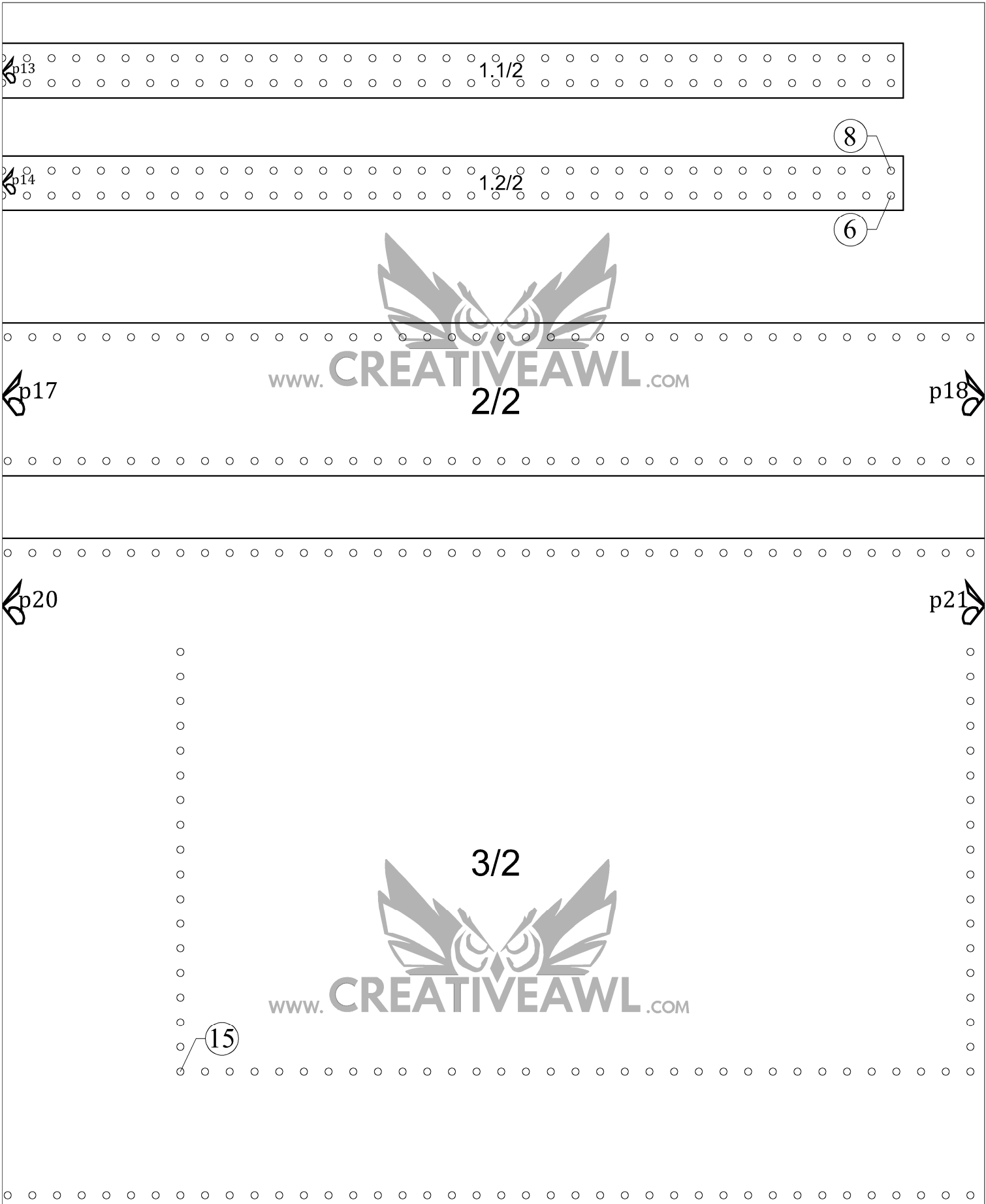

Elliptical osmotic bag

11

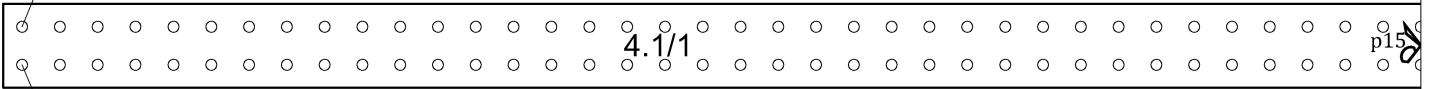

9

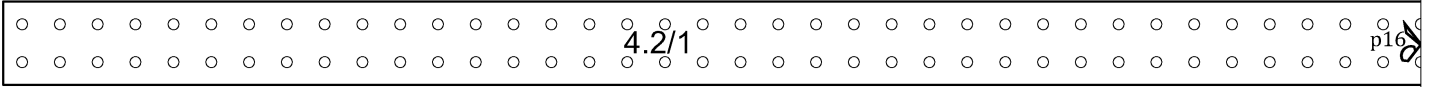

www.CREATIVEAWL.COM

2/3

p18

p19

p21

p22

3/3



www.CREATIVEAWL.COM

11 in LETTER 8,5 in

A4

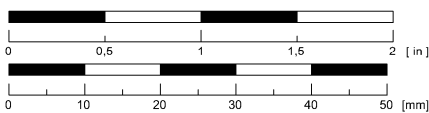

Elliptical osmetic bag

20

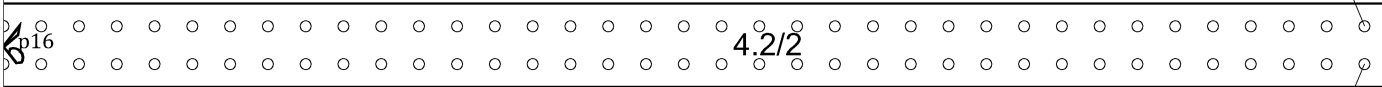
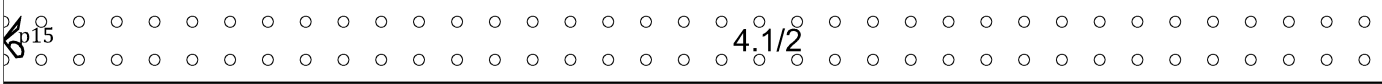

12

10

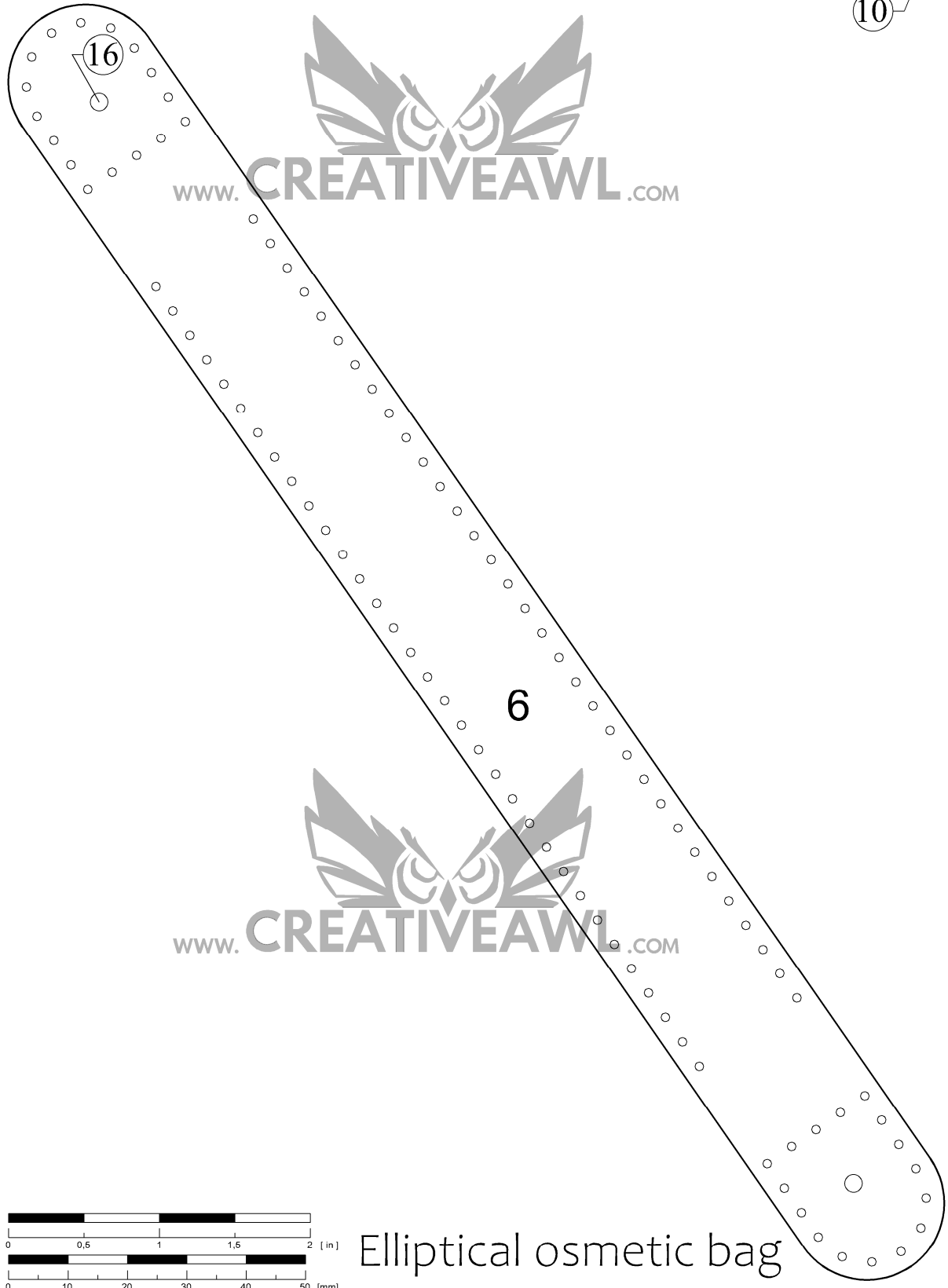
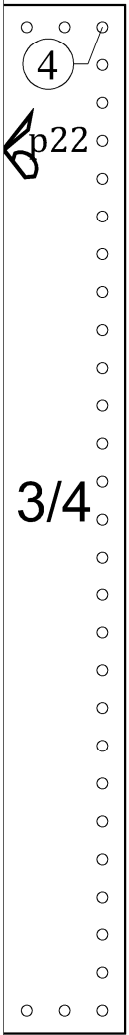
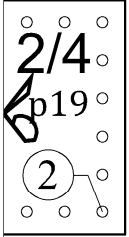

11 in LETTER 8,5 in

A4

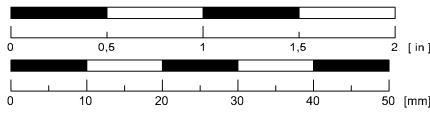

Elliptical osmotic bag

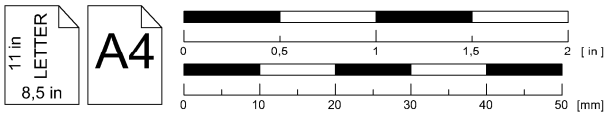
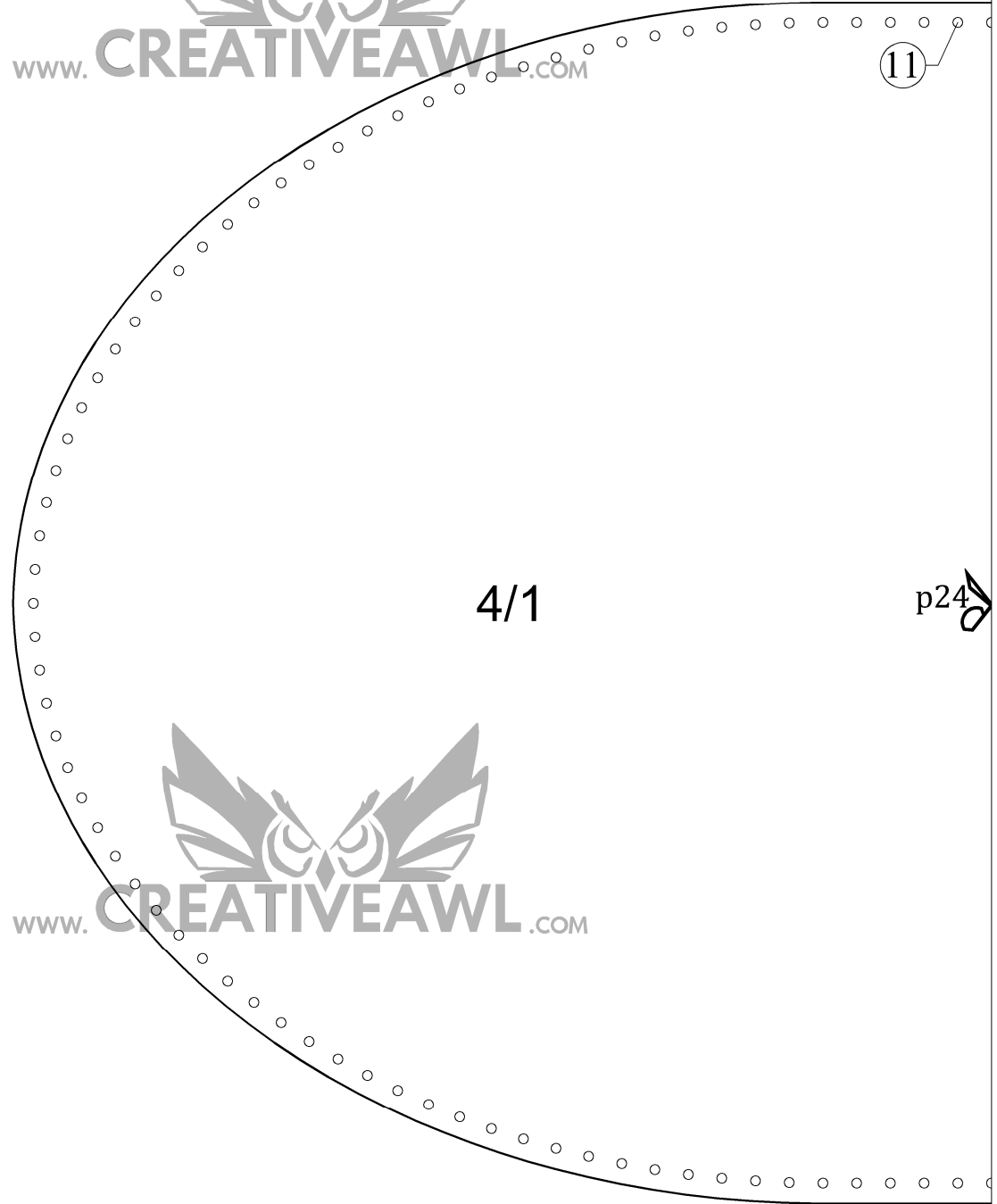
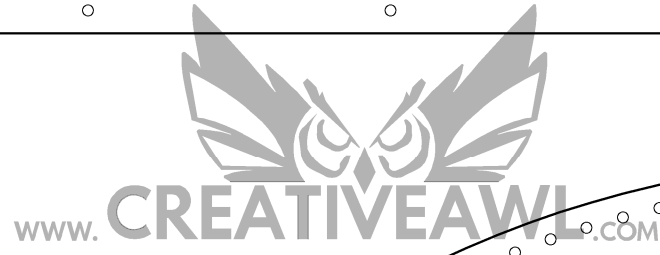
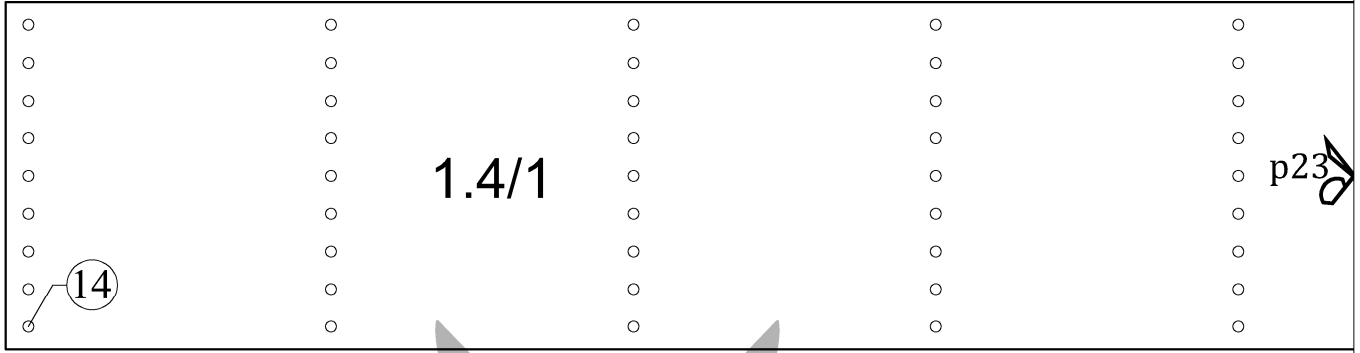

Elliptical osmetic bag

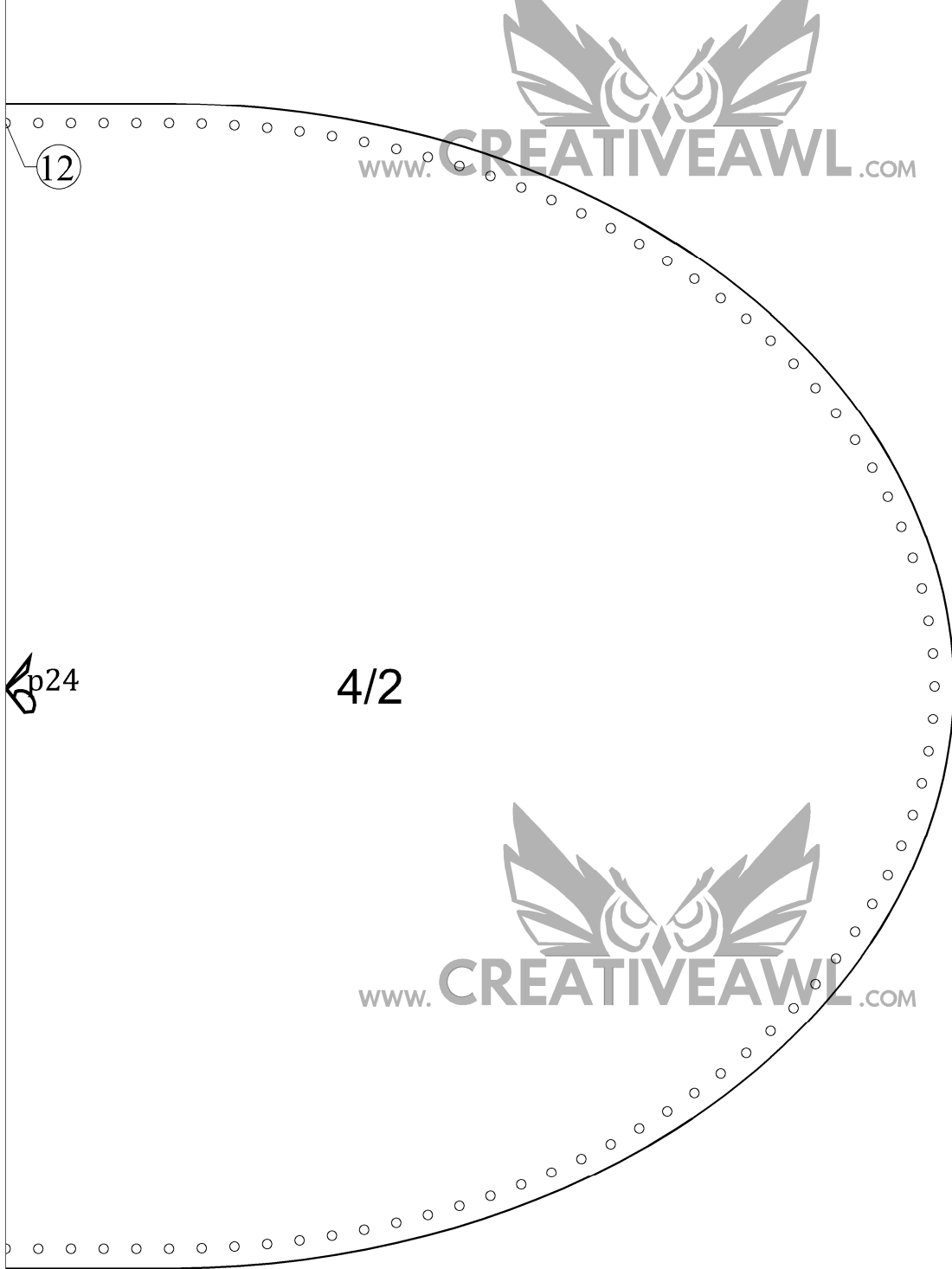
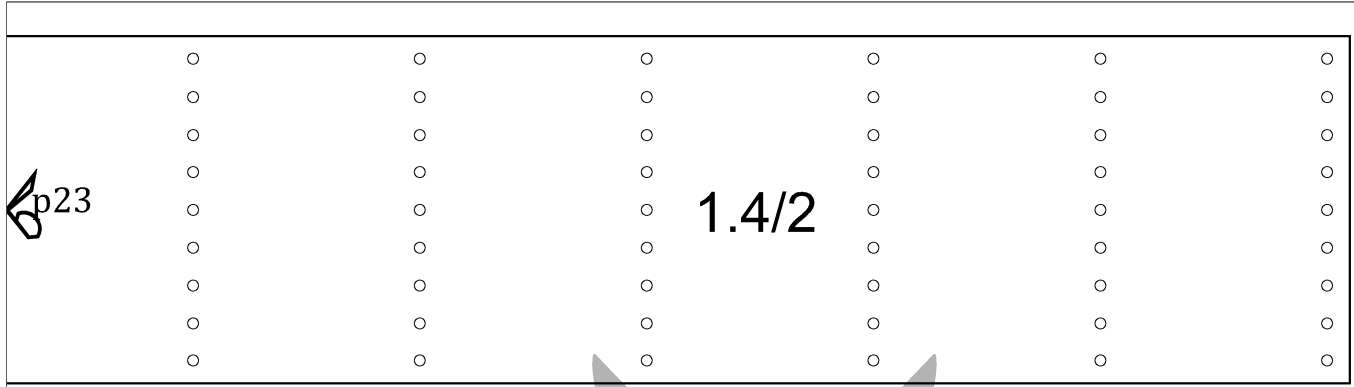

11 in LETTER 8,5 in

A4

0 0,5 1 1,5 2 [in]

0 10 20 30 40 50 [mm]

Elliptical osmetic bag

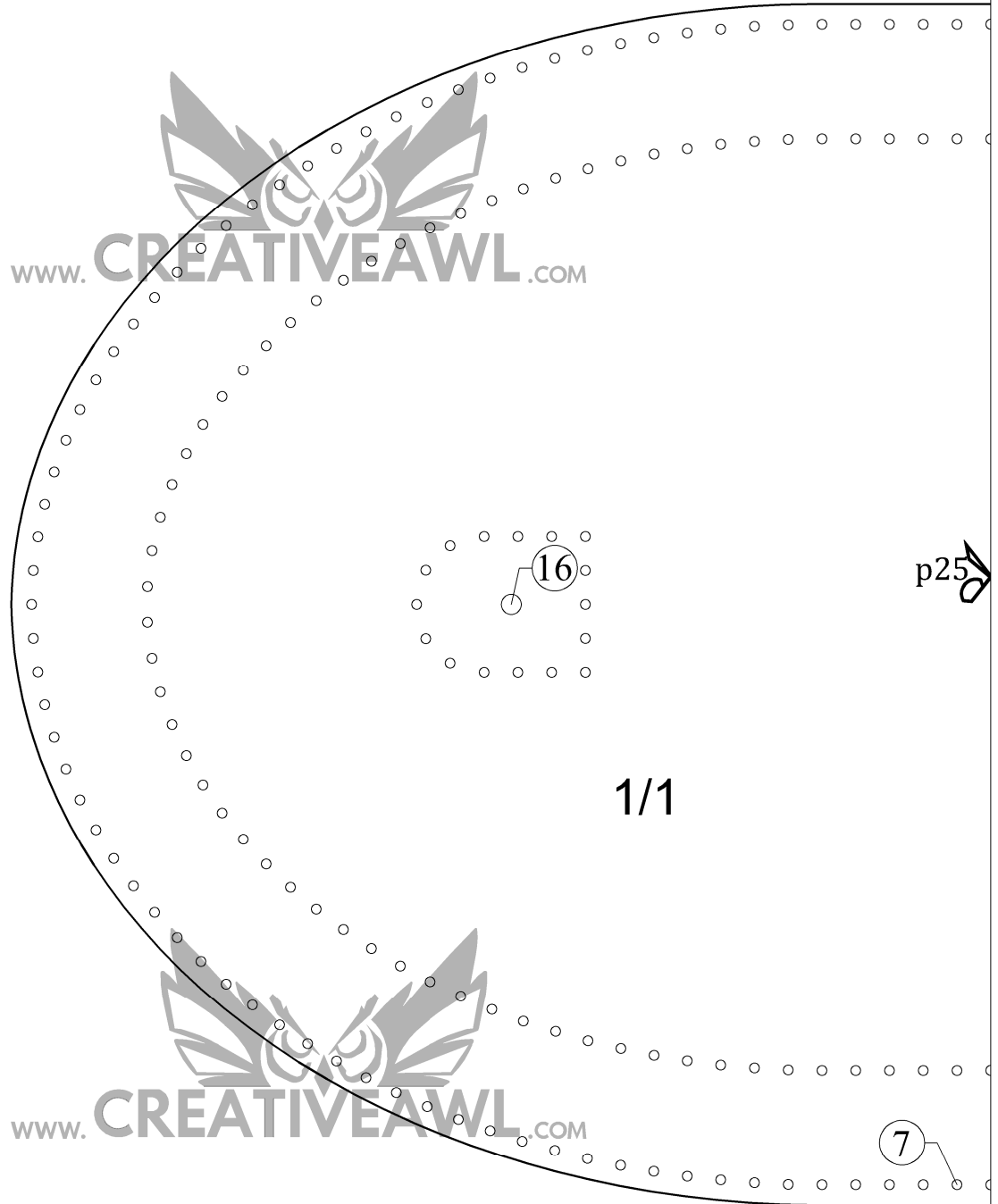
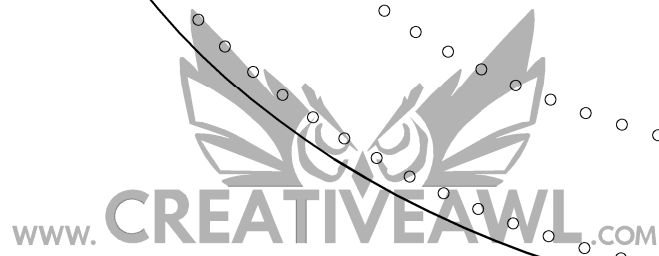
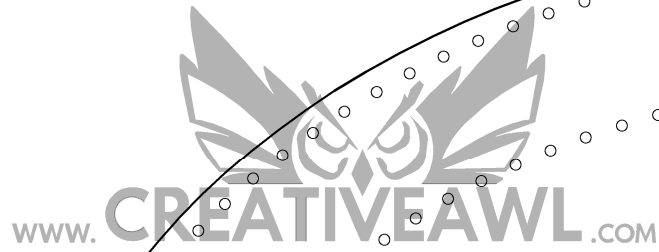

11 in
LETTER
8,5 in

A4

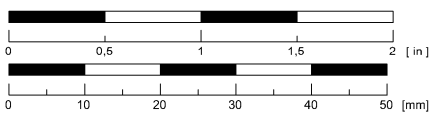

Elliptical osmotic bag

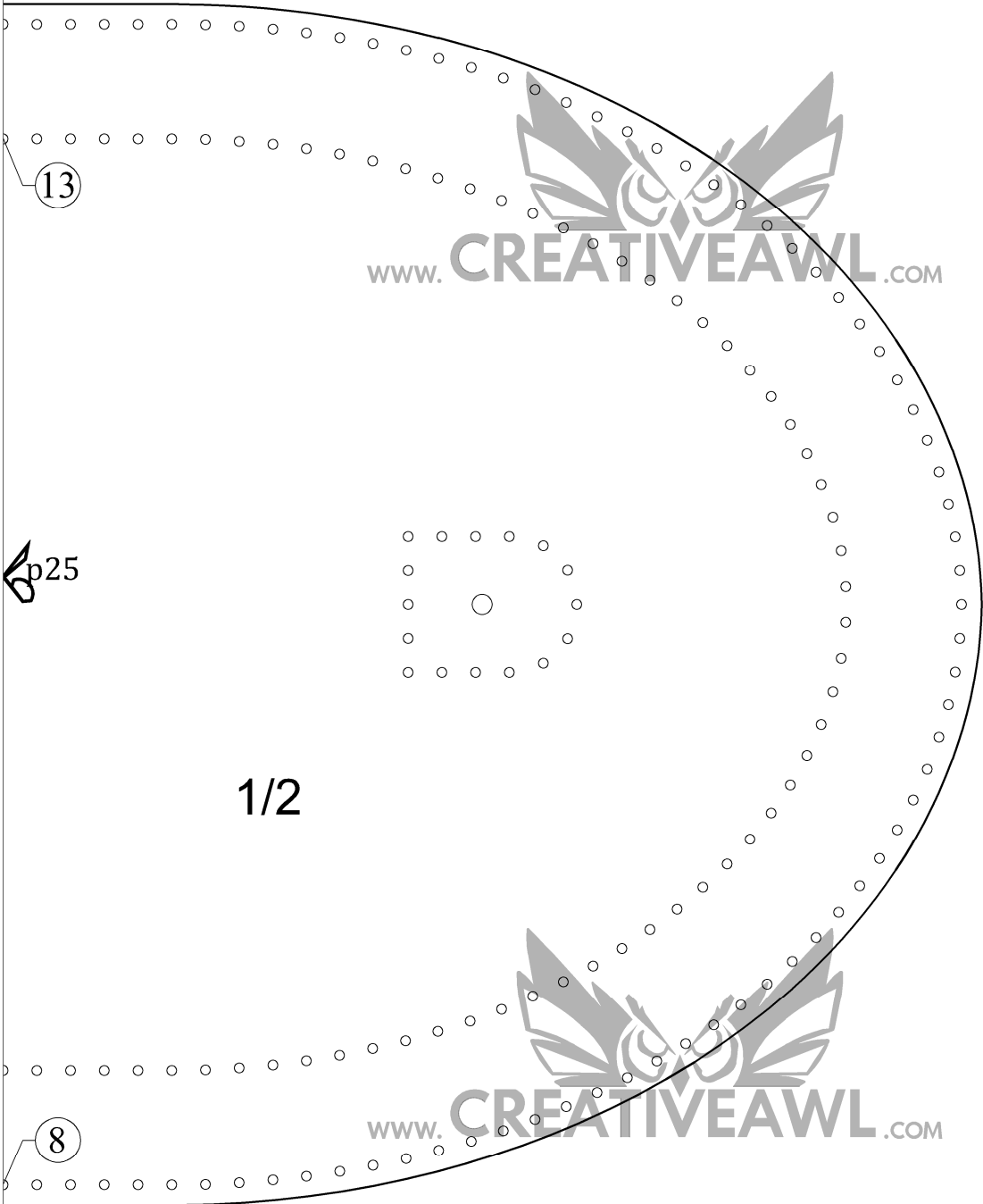
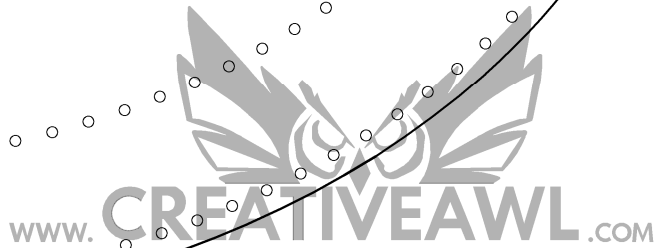
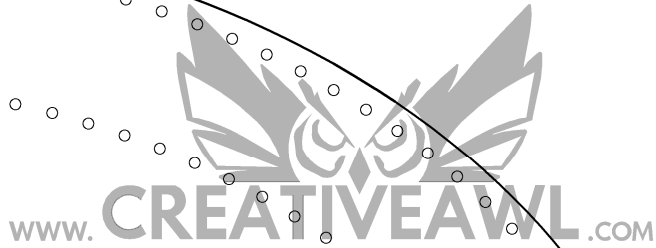

11 in
LETTER
8,5 in

A4

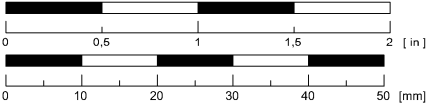

Elliptical osmotic bag

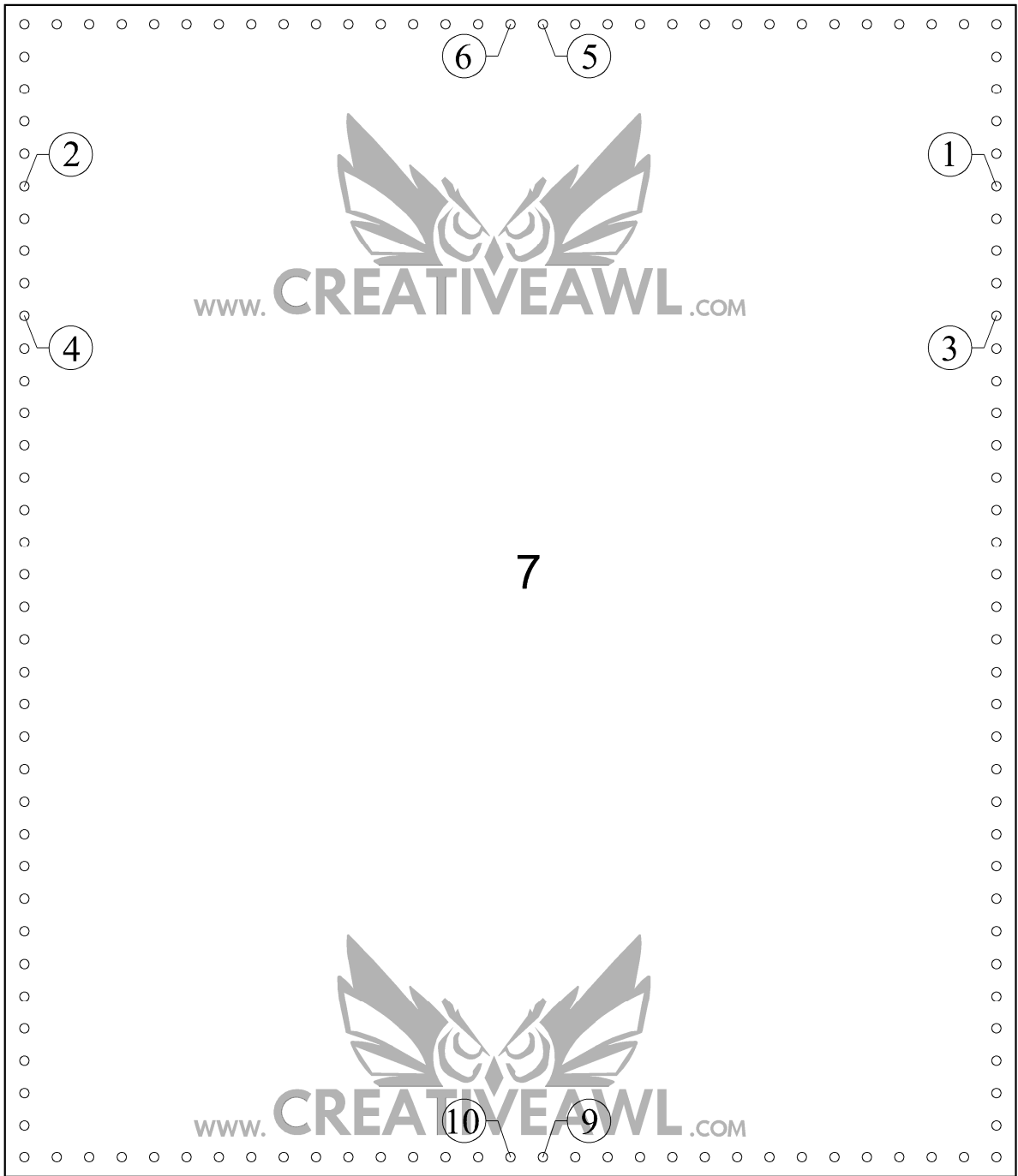

11 in
LETTER
8,5 in

A4

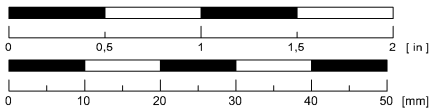

Elliptical osmotic bag

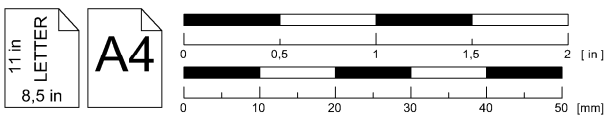
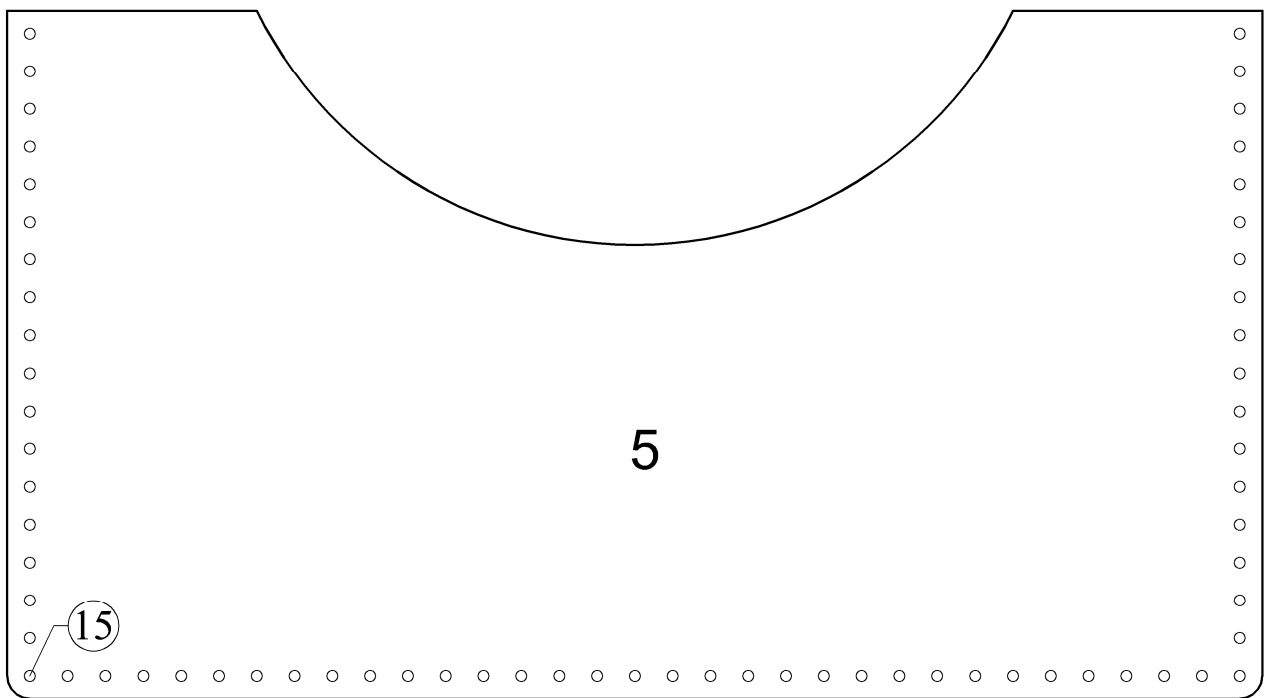

Elliptical osmotic bag

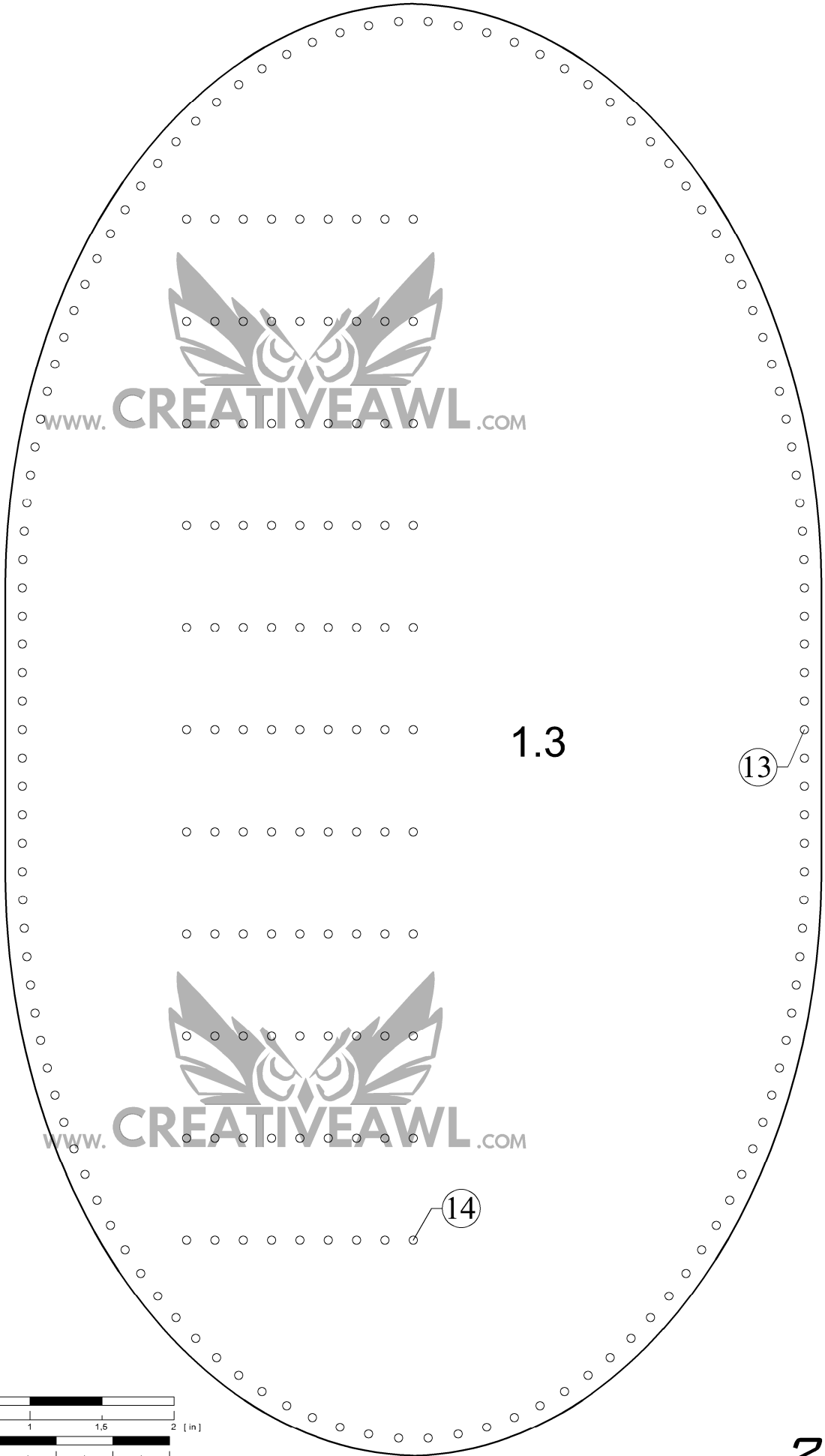

Elliptical
osmetic bag

11 in
LETTER
8,5 in

A4

0 0,5 1 1,5 2 [in]
0 10 20 30 40 50 [mm]

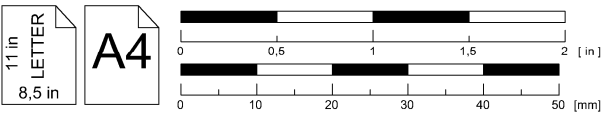

Additional versions of
the brush pockets

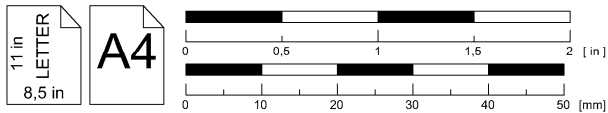
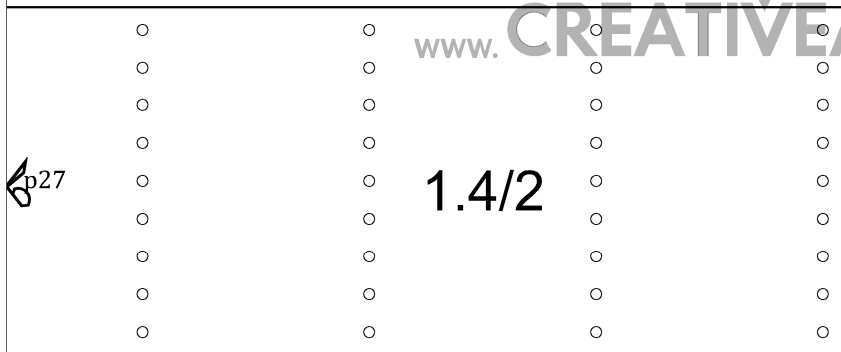
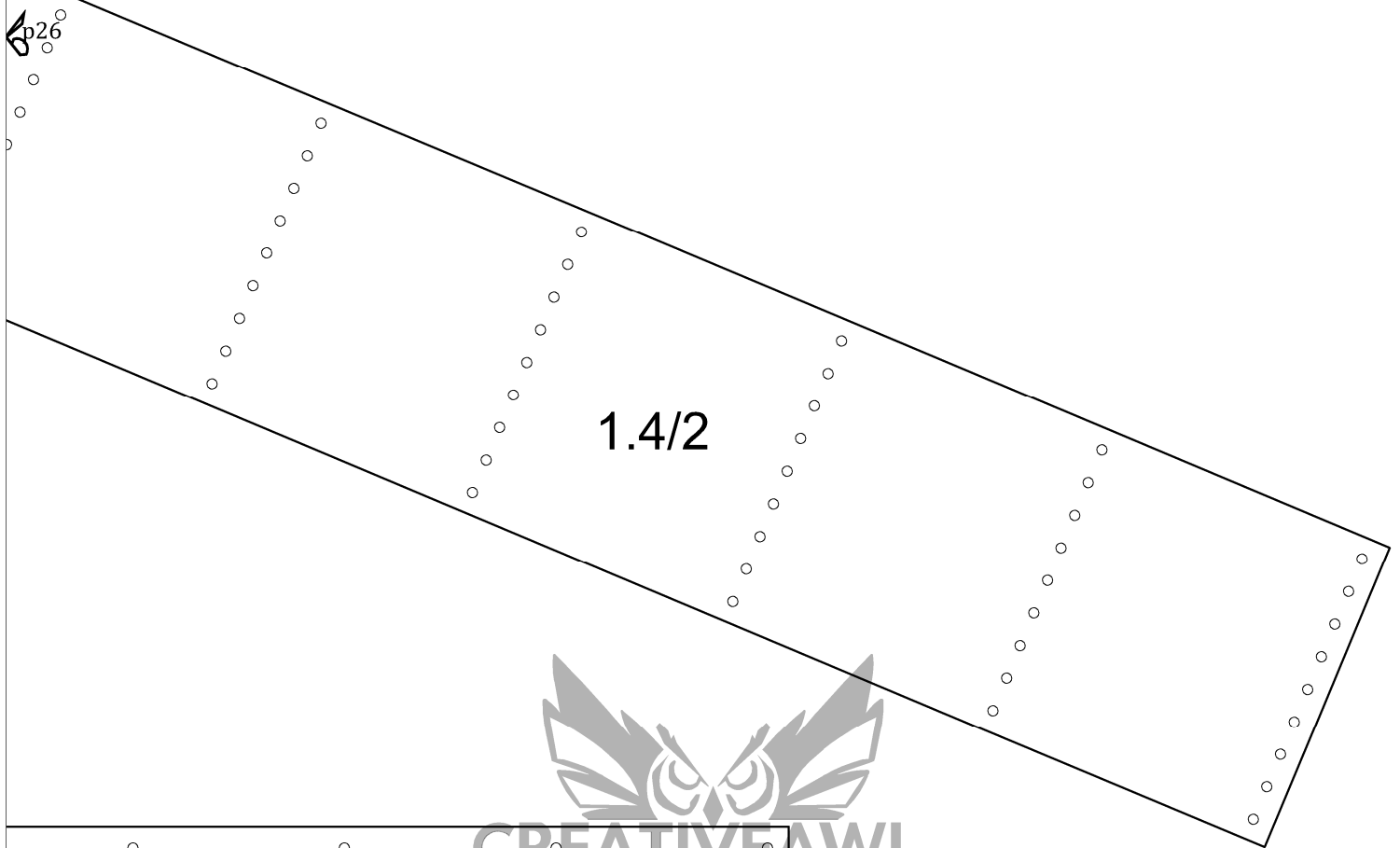

Additional versions of the brush pockets