

# Skipper cap

Digital Pattern PDF



**PRINT OUT THE PATTERN ACTUAL SIZE A4  
RECOMMENDED THREADS 0.8 MM**



**YouTube Channel**



**HARDWARE**

**- Buckle 15 mm  
- 2 Chicago Screws or Rivets  
Leather**

**Facebook Group**



**0.4 - 0.6 mm / 1 - 1½ oz  
1.5 - 1.6 mm / 3¾ - 4 oz  
1.8 - 2.0 mm / 4½ - 5 oz**

**For print the pattern out please select the size of the paper.  
You will use (A4, A1 or US LETTER)  
and then in the printer settings choose actual size.**

Print ×

Printer:  Properties Advanced [Help](#) ?

Copies:   Print in grayscale (black and white)  Save ink/toner ⓘ

**Pages to Print**  
 All  Current  Pages   
[▶ More Options](#)

**Page Sizing & Handling** ⓘ

**Size**  Poster  Multiple  Booklet

Fit  **Actual size**  Shrink oversized pages  Custom Scale:  %

Choose paper source by PDF page size

Print on both sides of paper

Orientation:  
 Auto  Portrait  Landscape

**Comments & Forms**  
 Summarize Comments

Page Setup... Print Cancel

Document: 8,3 x 11,7in  
8,27 x 11,69 Inches

**- HARDWARE -**  
- 2 x zip 18 cm  
- 4 x D-ring 15 mm  
- chain bag  
for the strap  
- 2 x big Trigger Hooks 15 mm  
- buckle 15 mm

---

Measurement of the leather  
You will need to finish this project: Bolt Bag  
52 cm x 38 cm / 20,47 in x 15,00 in  
plus strap

---

TOOLS  
- knife  
1.0 1.2 mm hole puncher  
- hammer  
- 2 needles  
- a home printer

**Tree House Patterns**  
TreeHousePatternsUK. All Rights Reserved

Page 2 of 12

190 mm

Size 54 cm

The circumference of the top of the cap is larger than that of the gusset,  
and the holes for the threads are further apart.

Therefore , for this project , use soft leather for the top and gusset which will drape well

. We used water buffalo leather with a thickness of 1.3 - 1.5 mm.

In this cap size, the thread passes from the top of the cap  
between part A and part B.  
(red mark on the pattern)

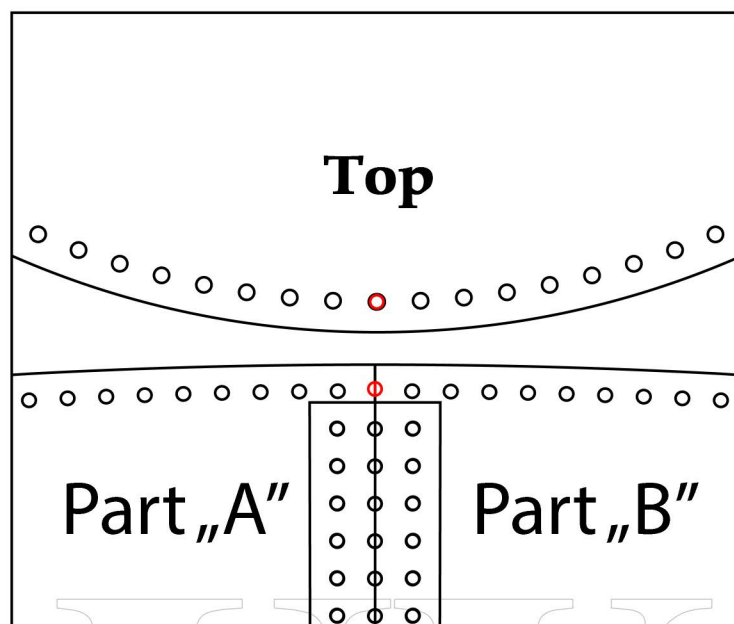

277 mm

Tree House Patterns

190 mm

Size 54 cm

Tree House Patterns

Soft leather 1.3 - 1.5 mm

C1

277 mm

Tree House Patterns

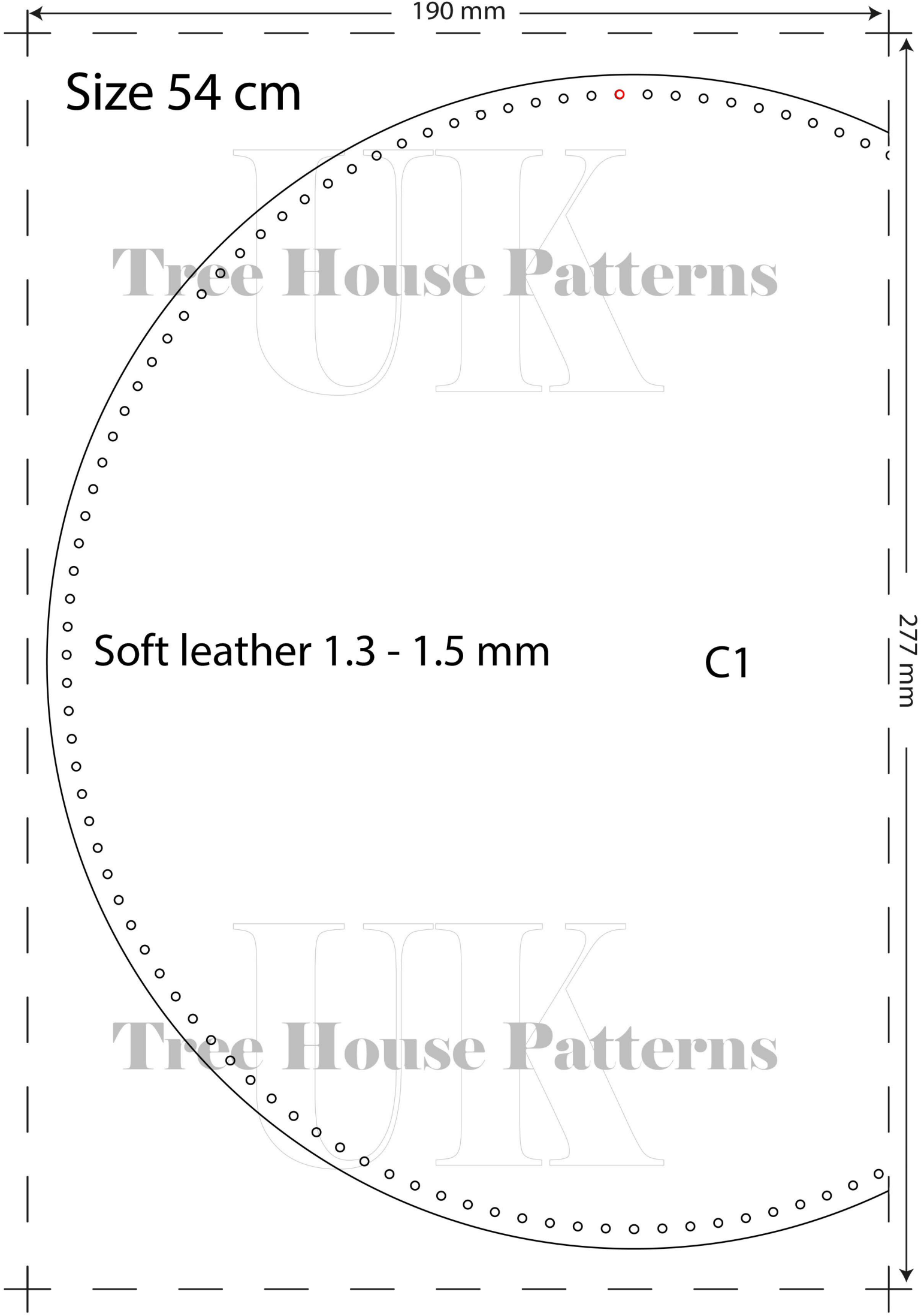

190 mm

277 mm

Tree House Patterns

Tree House Patterns

C2

Size 54 cm

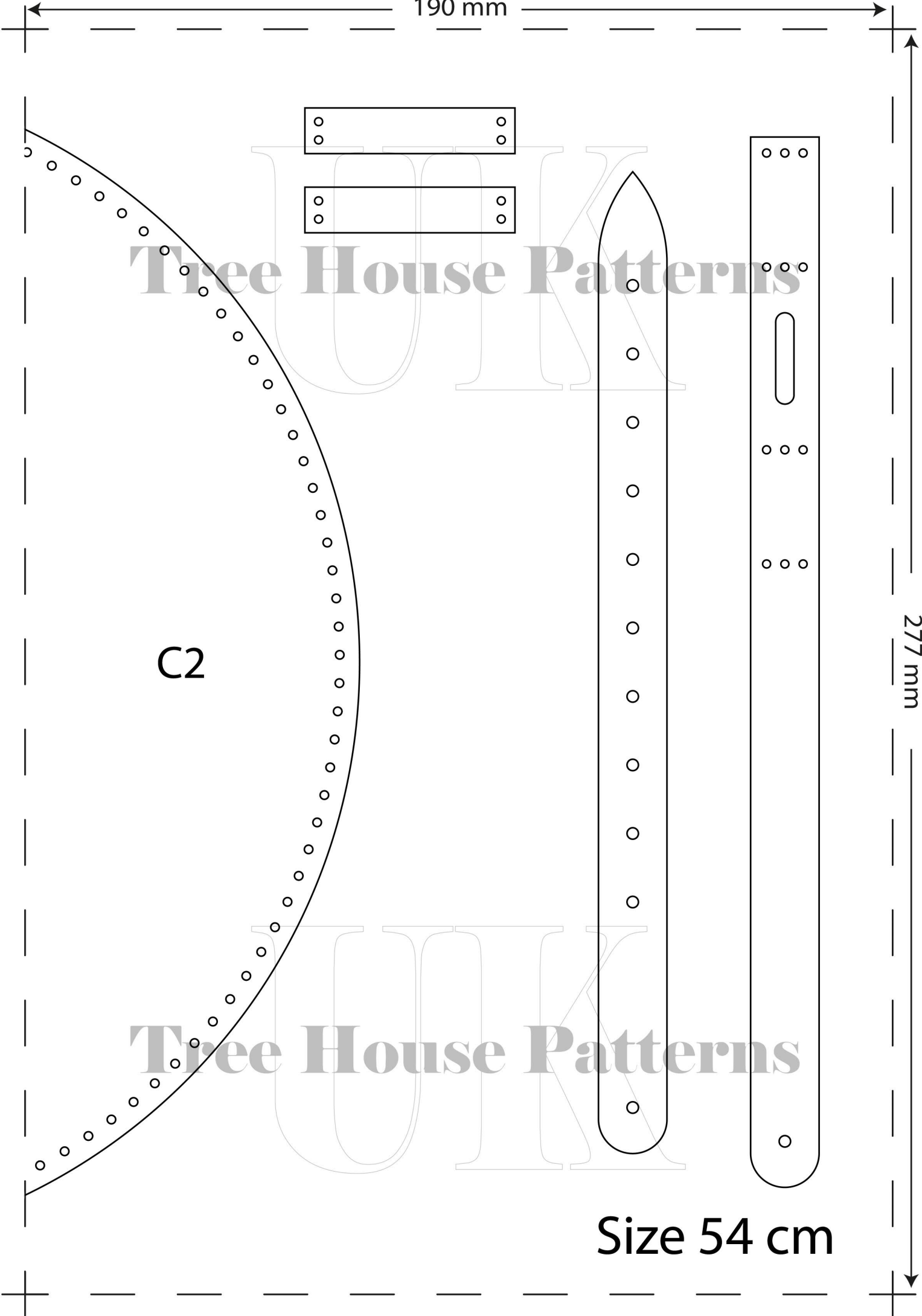

190 mm

Size 54 cm

Tree House Patterns  
Soft leather 1.3 - 1.5 mm  
Part „A”

A1

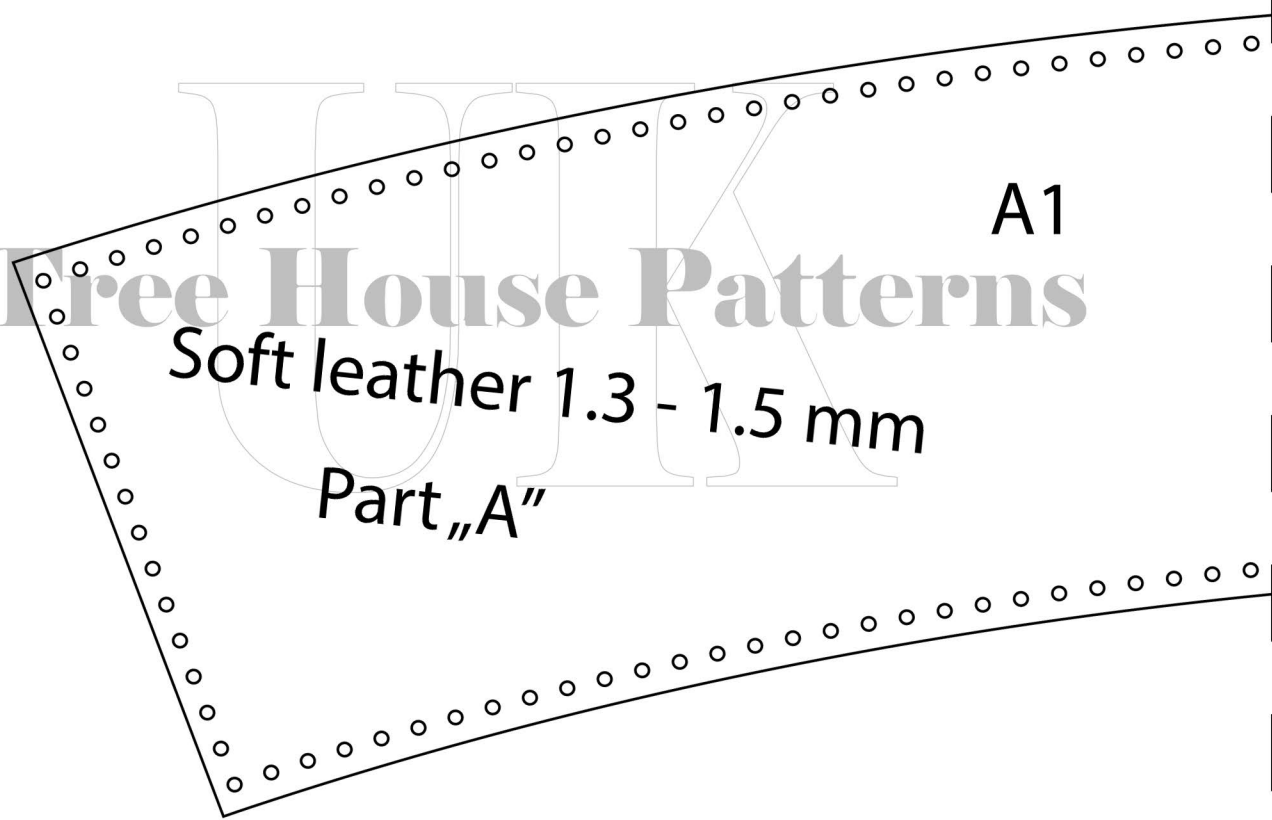

277 mm

Tree House Patterns

B1

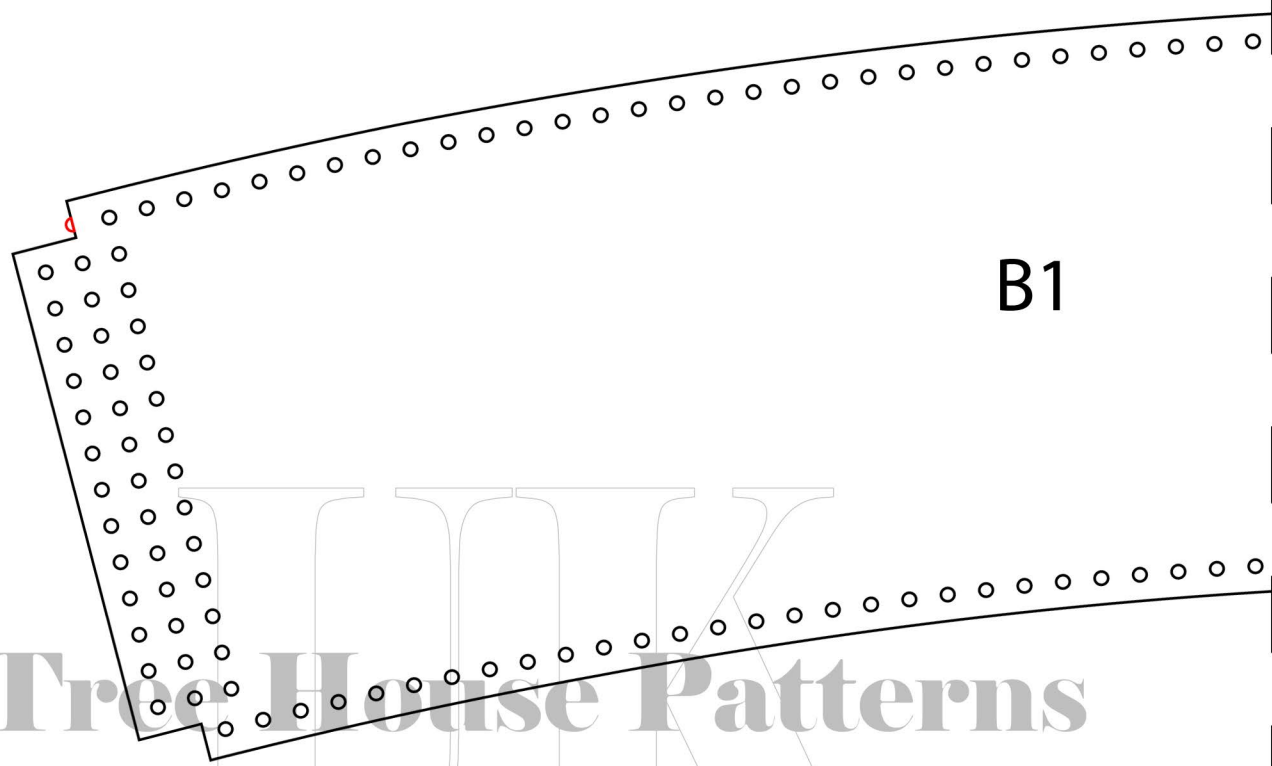

190 mm

277 mm

A2

Tree House Patterns

B2

Soft leather 1.3 - 1.5 mm  
Part „B“

Tree House Patterns

Size 54 cm

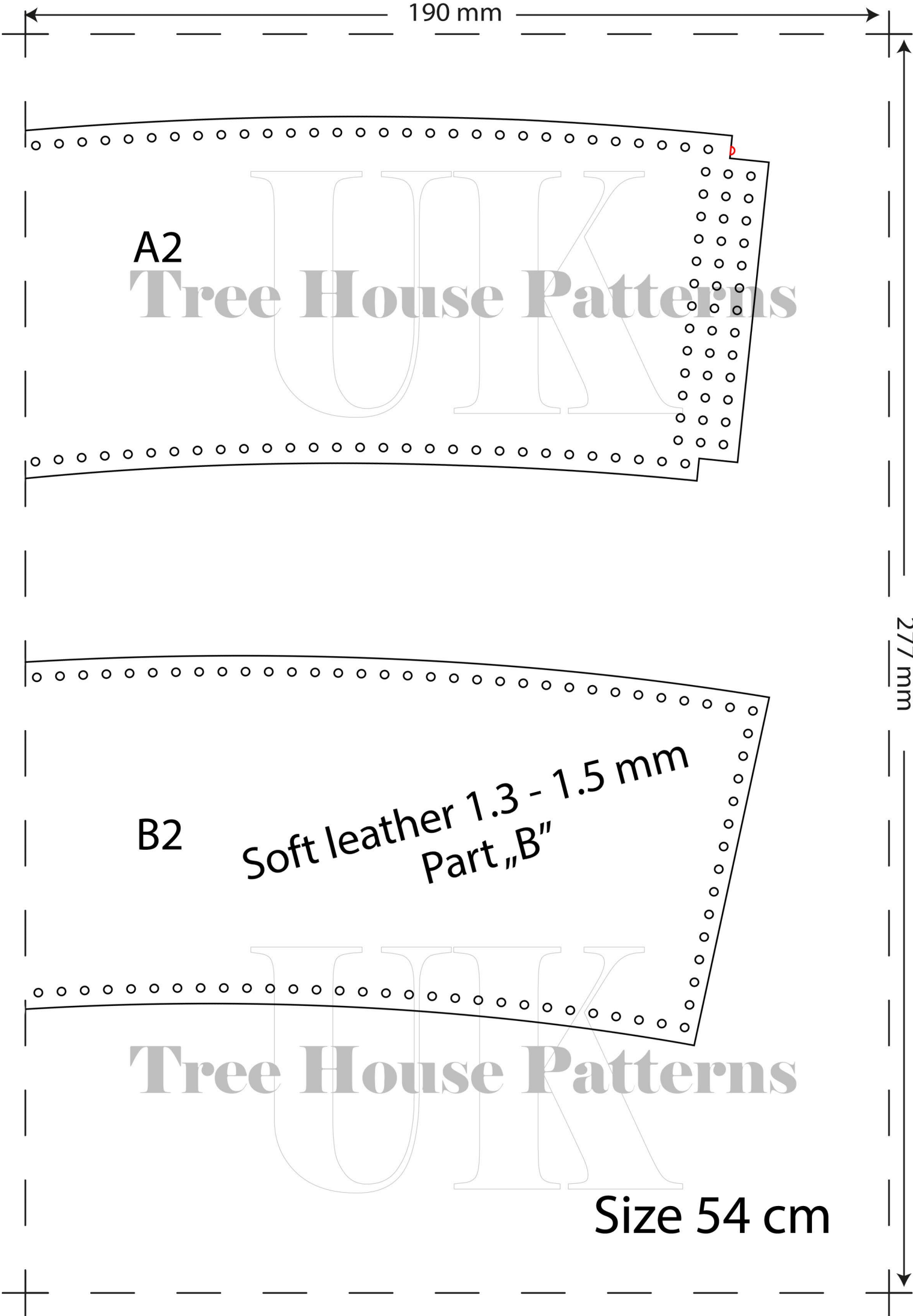

190 mm

Size 54 cm

Tree House Patterns

Leather 0.4 - 0.6 mm

Leather 1.5 - 1.6 mm

D1

E1

Tree House Patterns

277 mm

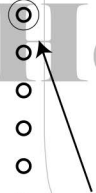



190 mm

Size 54 cm

Visor

Tree House Patterns

D2

E2

277 mm

Tree House Patterns

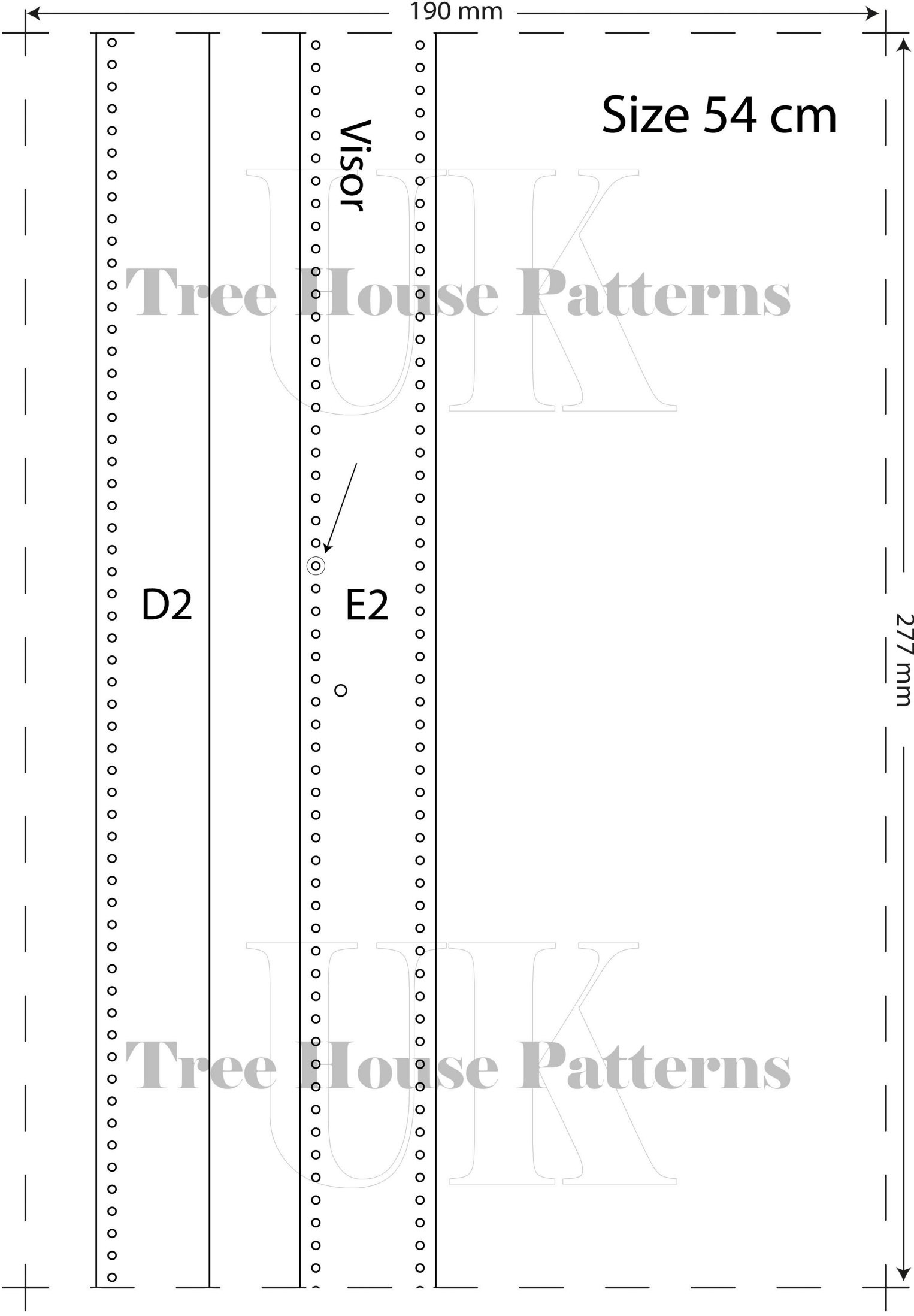

190 mm

D3

E3

Size 54 cm

Tree House Patterns

Leather 1.8 - 2.0 mm

277 mm

Tree House Patterns

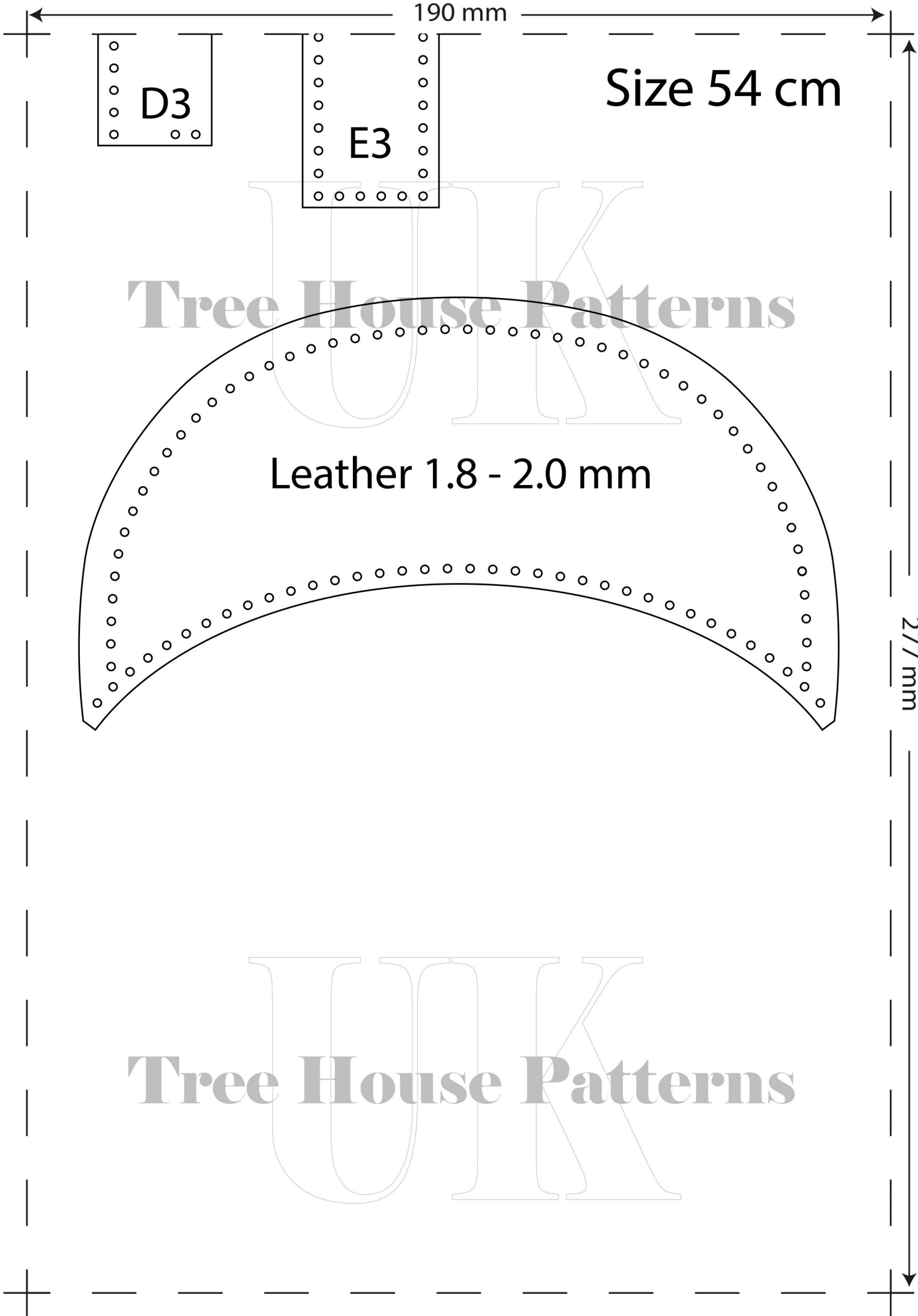

190 mm

Size 55 cm

The circumference of the top of the cap is larger than that of the gusset,  
and the holes for the threads are further apart.

Therefore , for this project , use soft leather for the top and gusset which will drape well  
. We used water buffalo leather with a thickness of 1.3 - 1.5 mm.

In this cap size, the thread passes from the top of the cap  
between part A and part B.  
(red mark on the pattern)

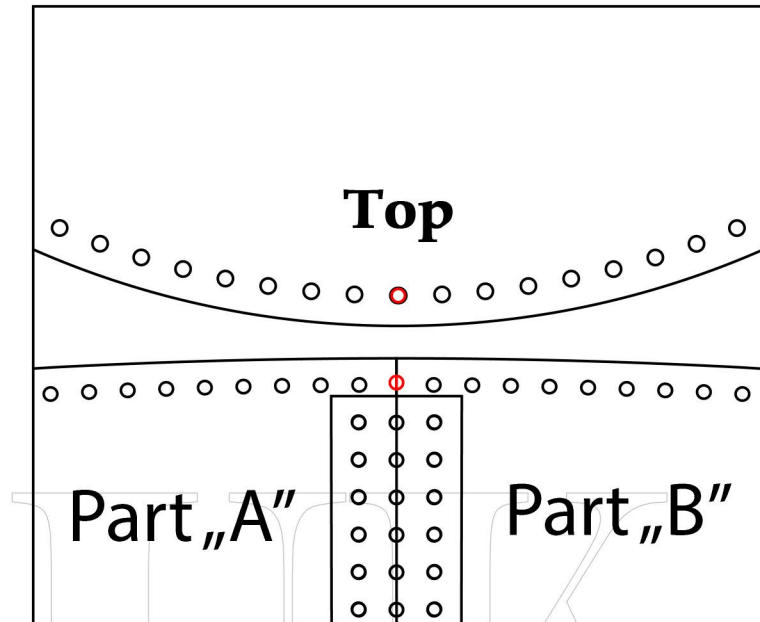

277 mm

Tree House Patterns

190 mm

Size 55 cm

Tree House Patterns

Soft leather 1.3 - 1.5 mm

C1

277 mm

Tree House Patterns

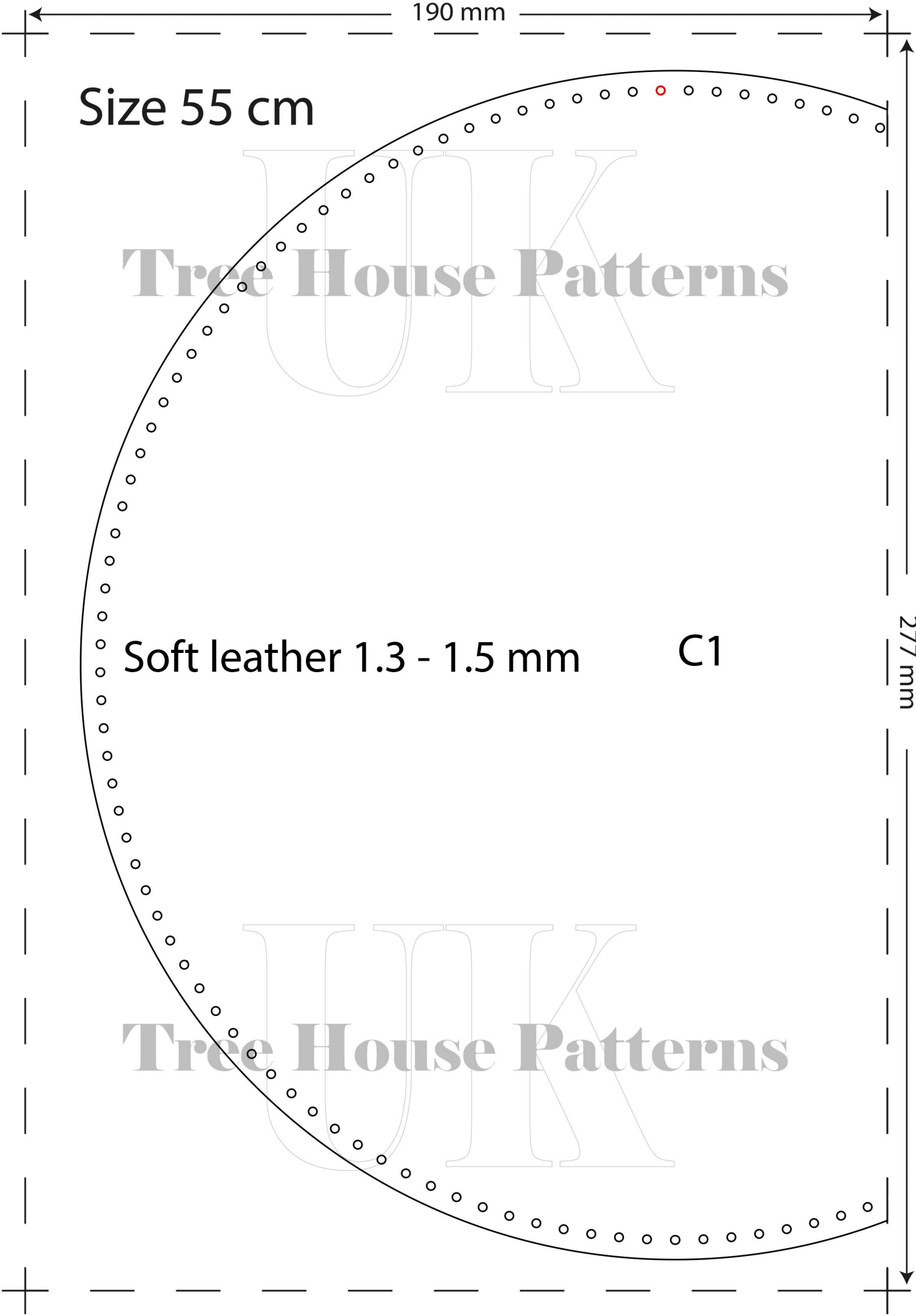

190 mm

277 mm

Tree House Patterns

Tree House Patterns

Size 55 cm

C2

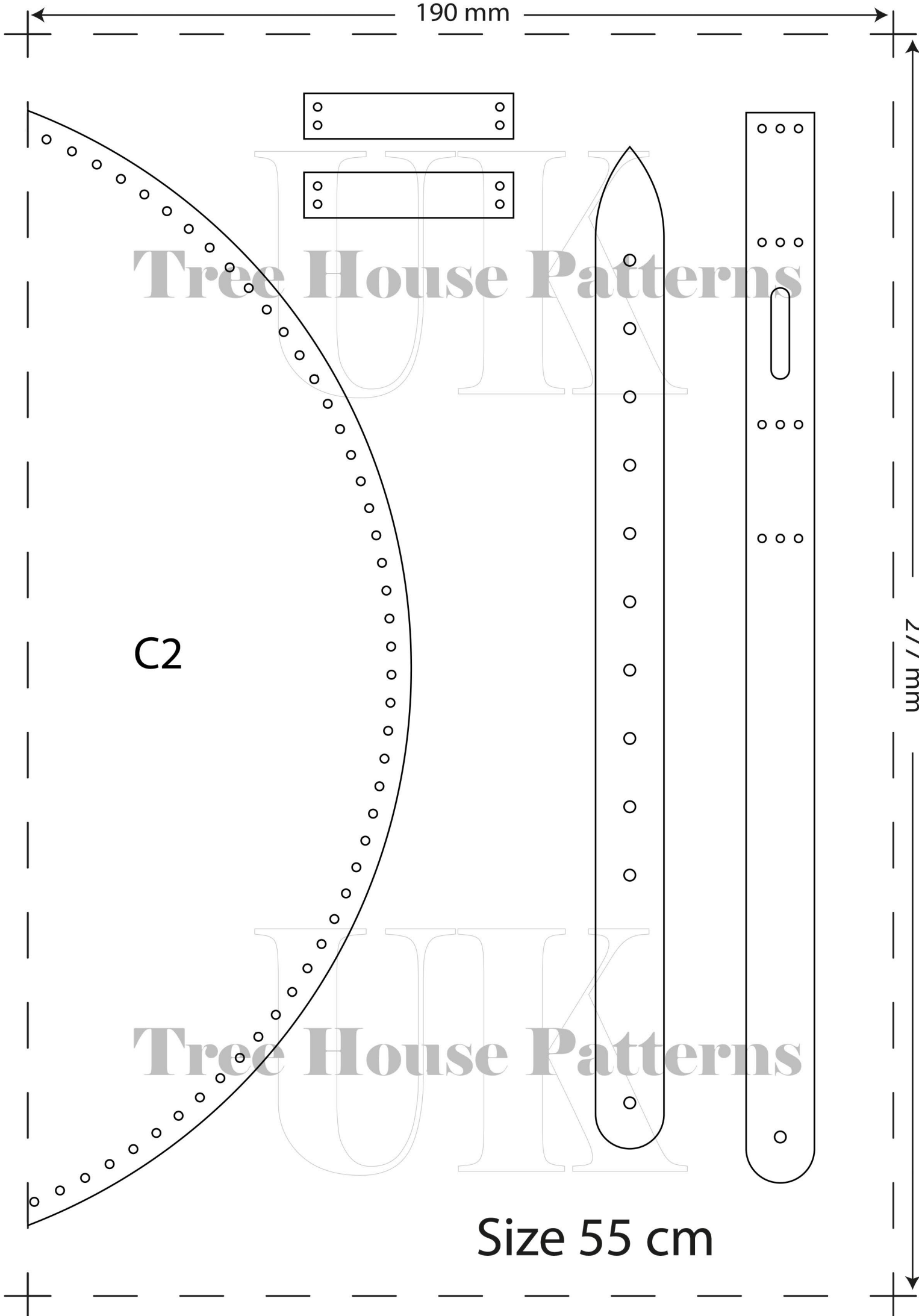

190 mm

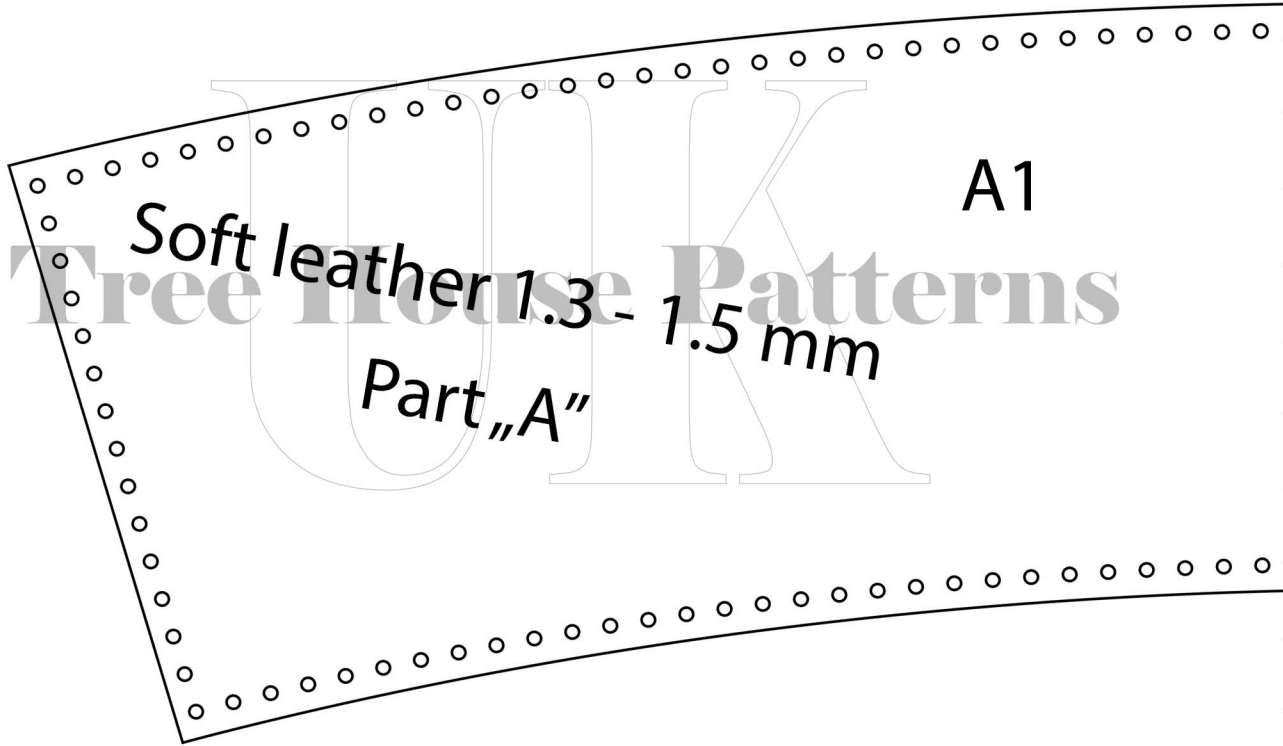

A1

Soft leather 1.3 - 1.5 mm  
Part „A”

Size 55 cm

277 mm

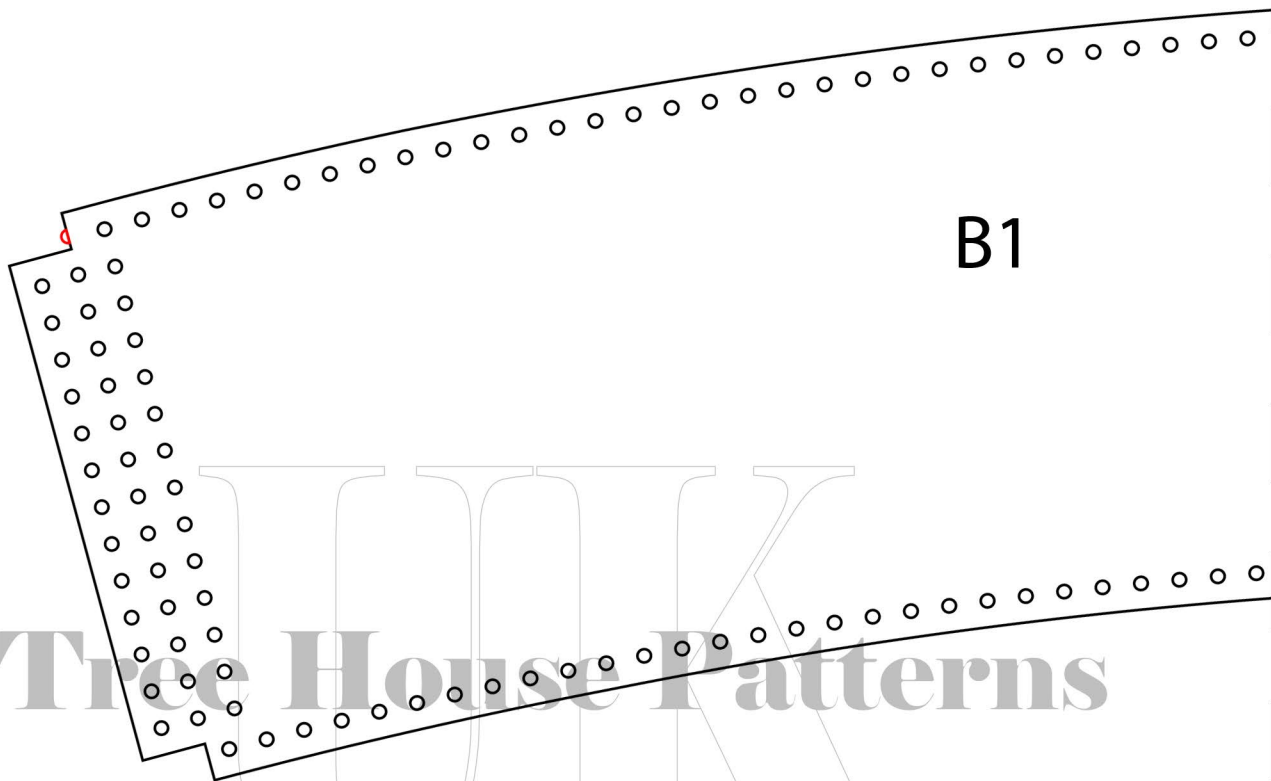

B1

Tree House Patterns

190 mm

A2

Tree House Patterns

277 mm

B2

Soft leather 1.3 - 1.5 mm  
Part "B"

Tree House Patterns

Size 55 cm

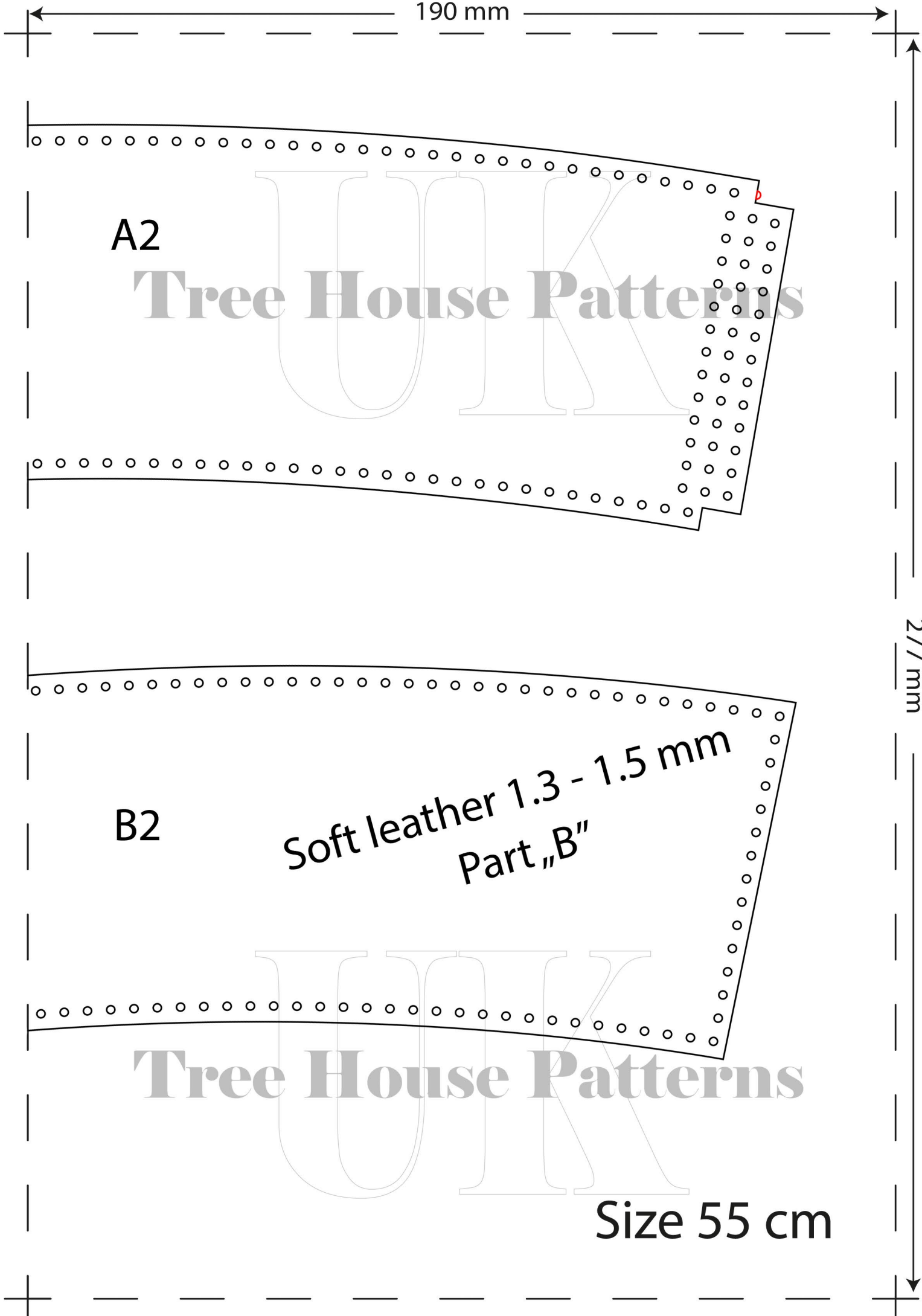

190 mm

277 mm

Size 55 cm

Leather 0.4 - 0.6 mm

D1

Leather 1.5 - 1.6 mm

E1

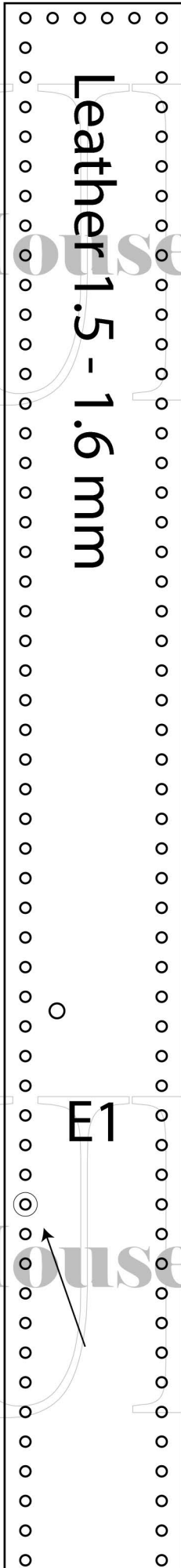
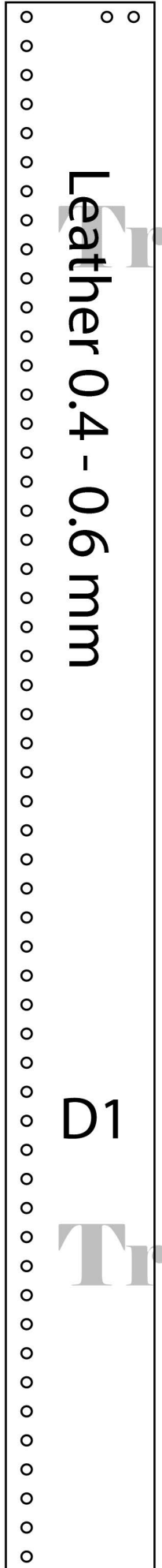



190 mm

Size 55 cm

Visor

Tree House Patterns

D2

E2

o

277 mm

Tree House Patterns

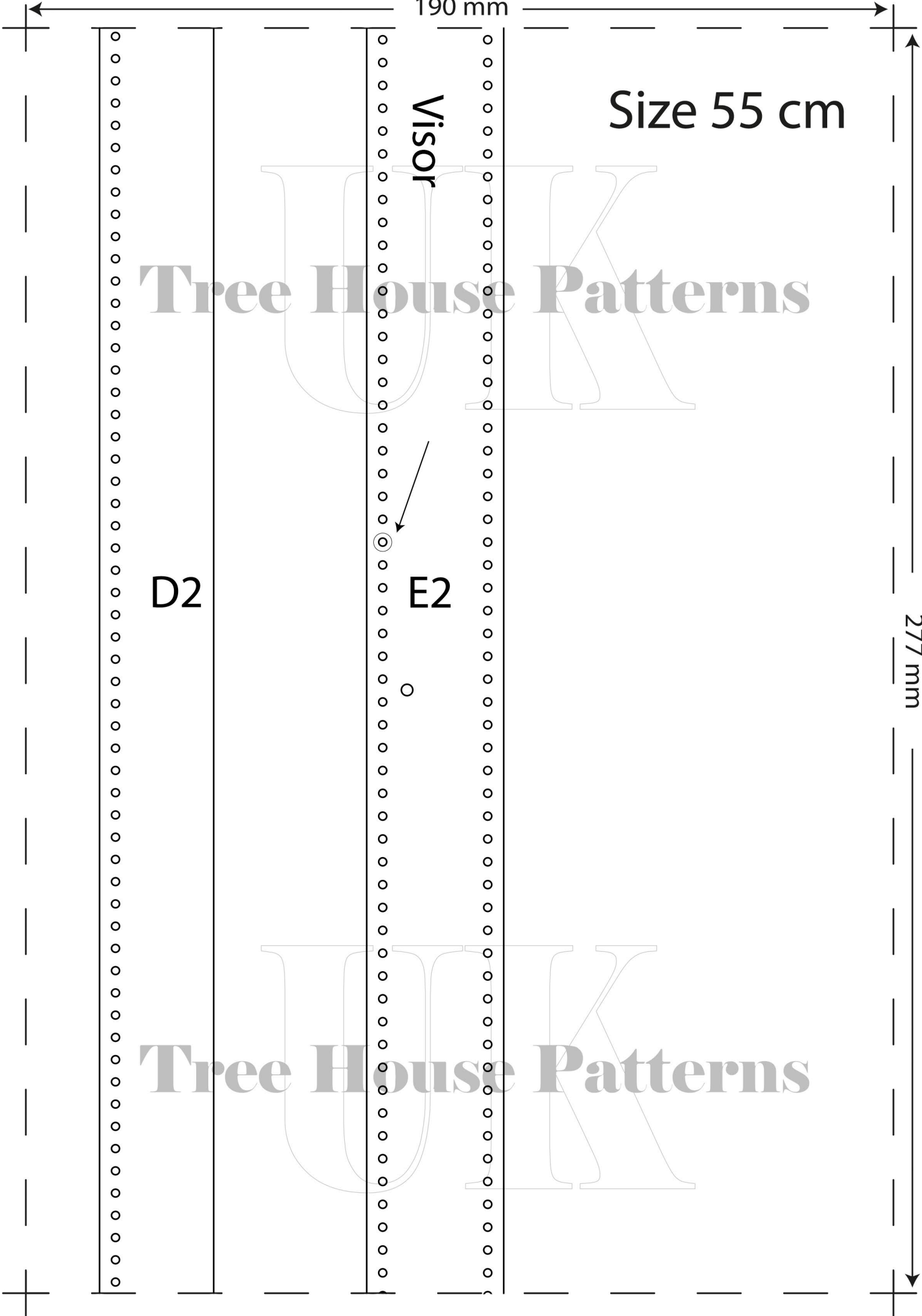

190 mm

D3

E3

Size 55 cm

Tree House Patterns

277 mm

Leather 1.8 - 2.0 mm

Tree House Patterns

190 mm

Size 56 cm

The circumference of the top of the cap is larger than that of the gusset, and the holes for the threads are further apart.

Therefore , for this project , use soft leather for the top and gusset which will drape well . We used water buffalo leather with a thickness of 1.3 - 1.5 mm.

In this cap size, the thread passes from the top of the cap between part A and part B.  
(red mark on the pattern)

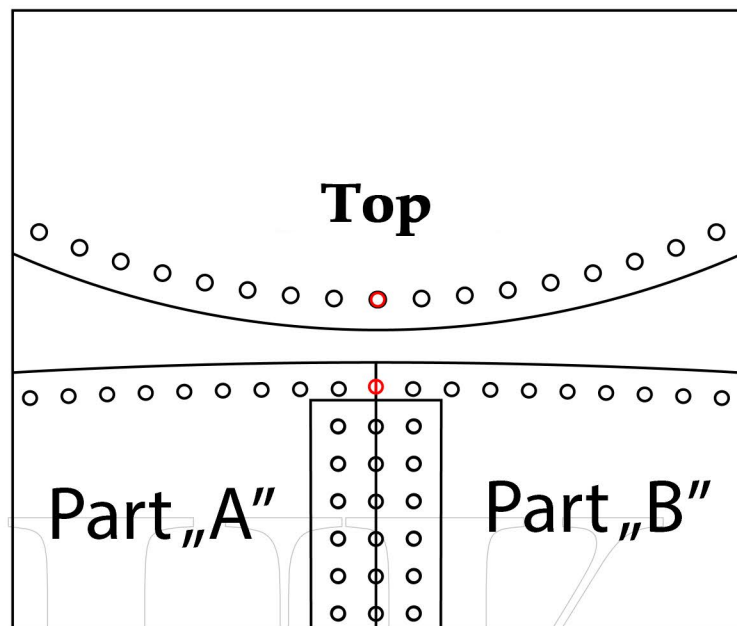

277 mm

Tree House Patterns

190 mm

Size 56 cm

Tree House Patterns

Soft leather 1.3 - 1.5 mm

C1

277 mm

Tree House Patterns

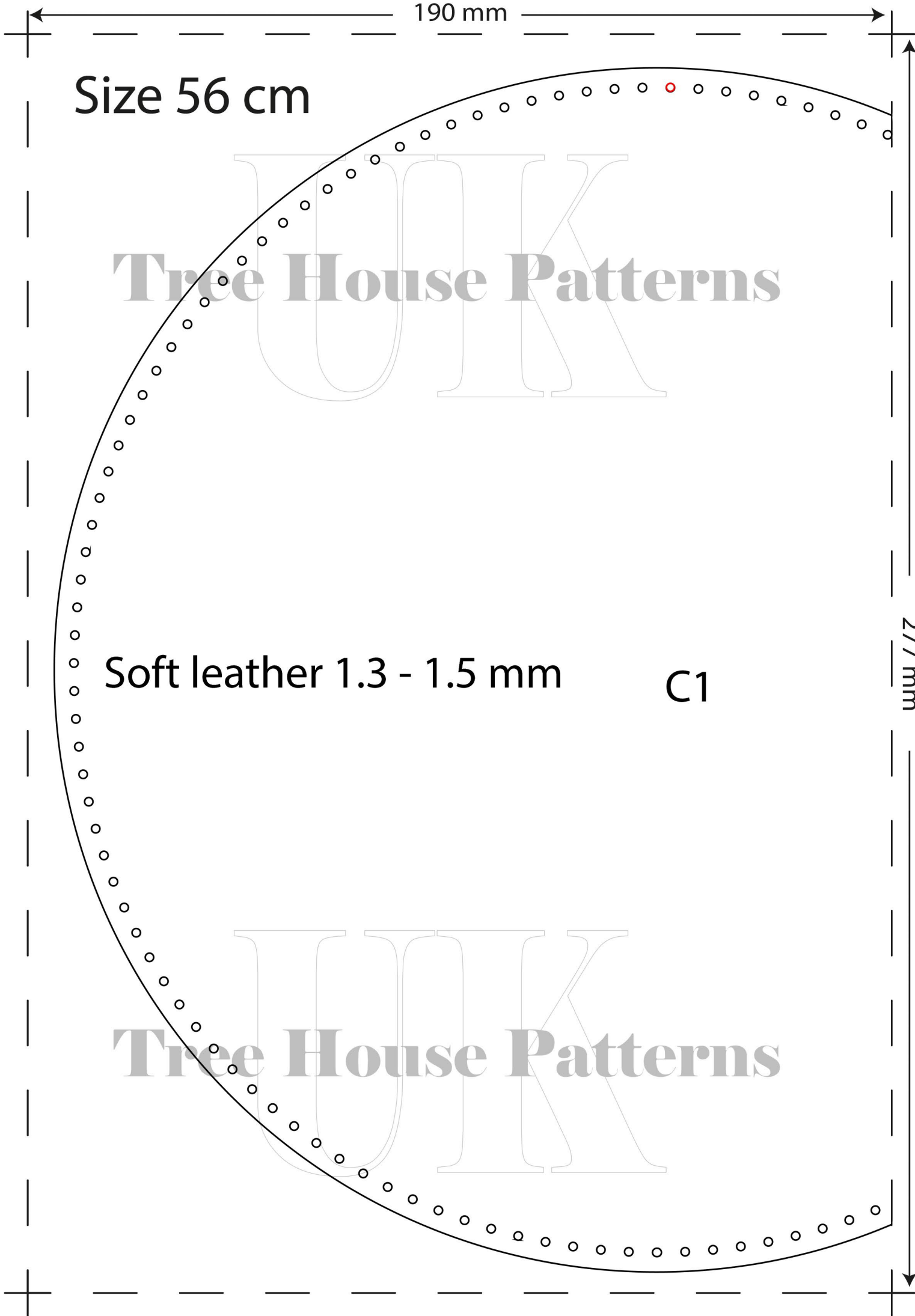

190 mm

277 mm

Tree House Patterns

Tree House Patterns

C2

Size 56 cm

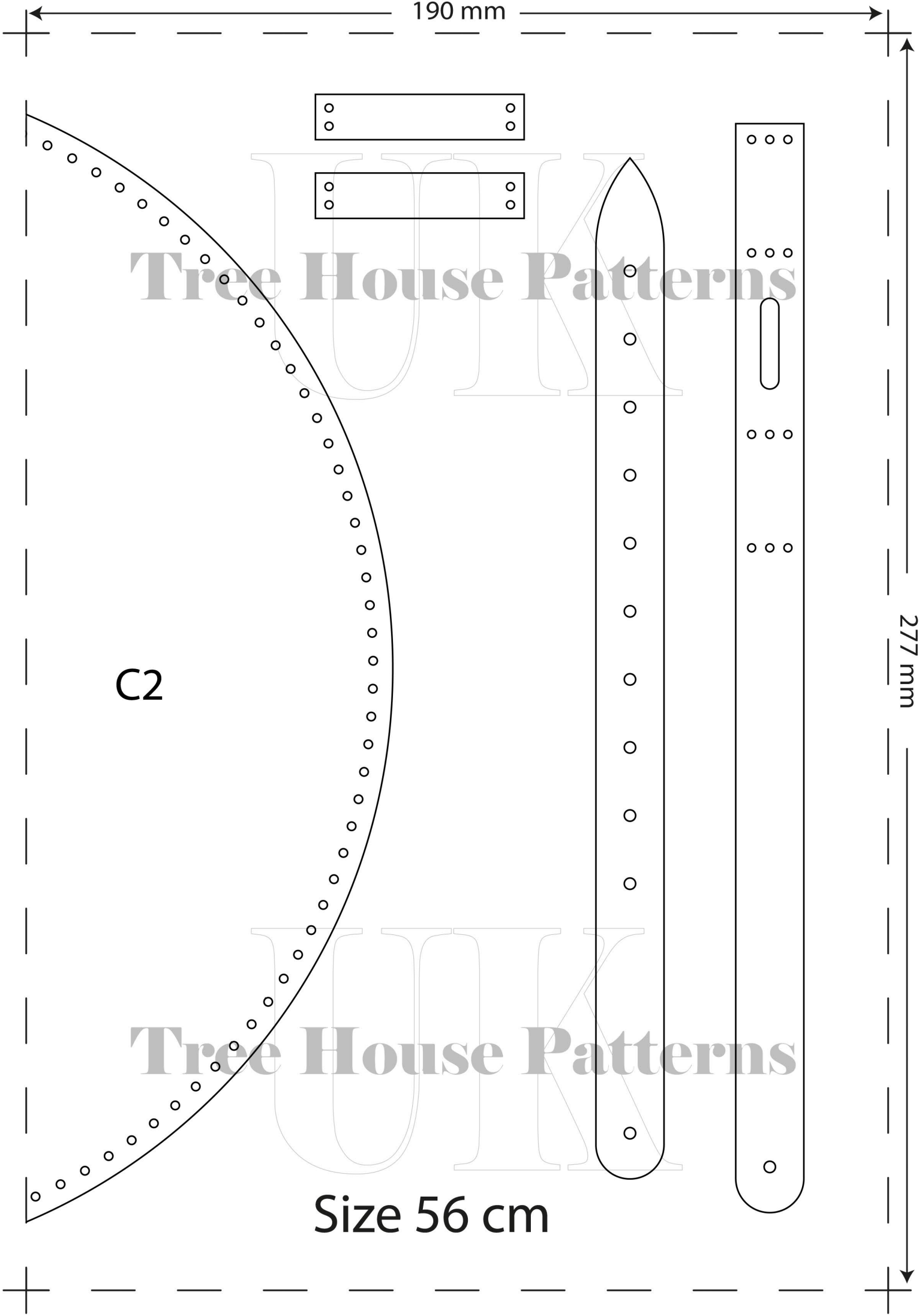

190 mm

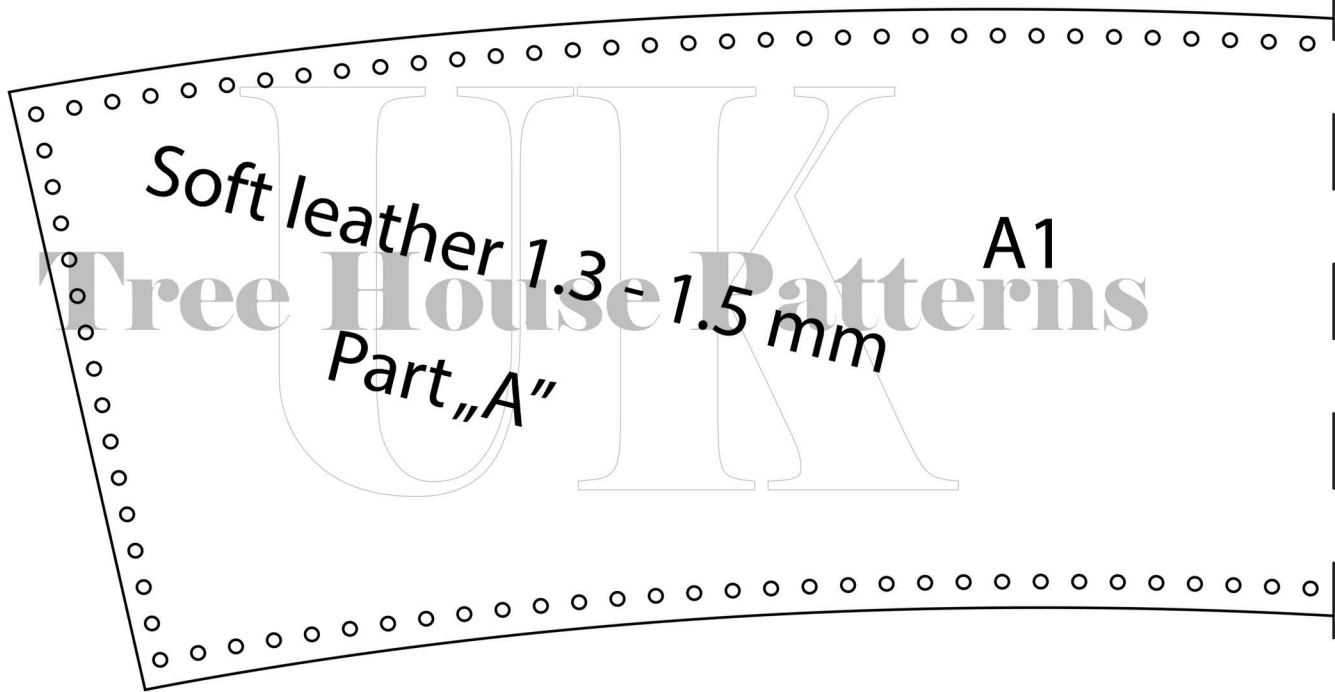

Soft leather 1.3 - 1.5 mm  
Part „A“

A1

Size 56 cm

277 mm

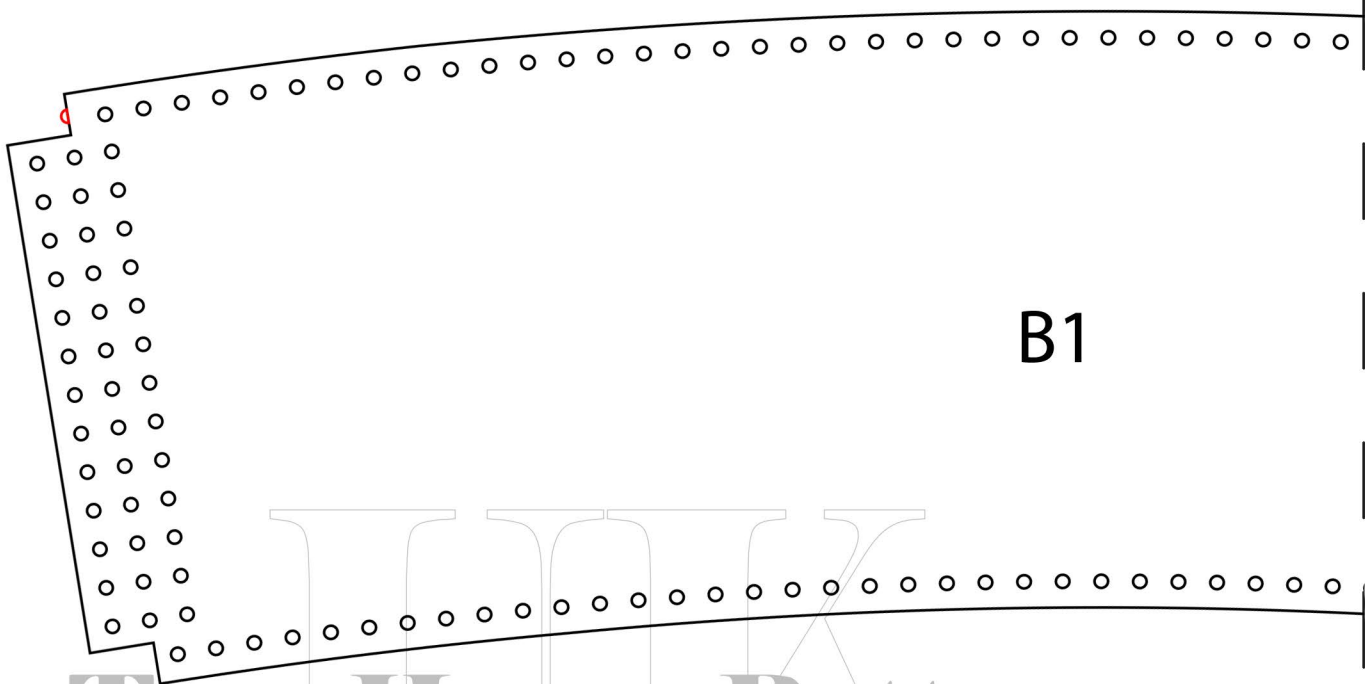

B1

Tree House Patterns

190 mm

277 mm

A2

Tree House Patterns

B2

Soft leather 1.3 - 1.5 mm  
Part „B“

Tree House Patterns

Size 56 cm

190 mm

Size 56 cm

Leather 0.4 - 0.6 mm

Leather 1.5 - 1.6 mm

D1

E1

277 mm

Tree House Patterns

Tree House Patterns

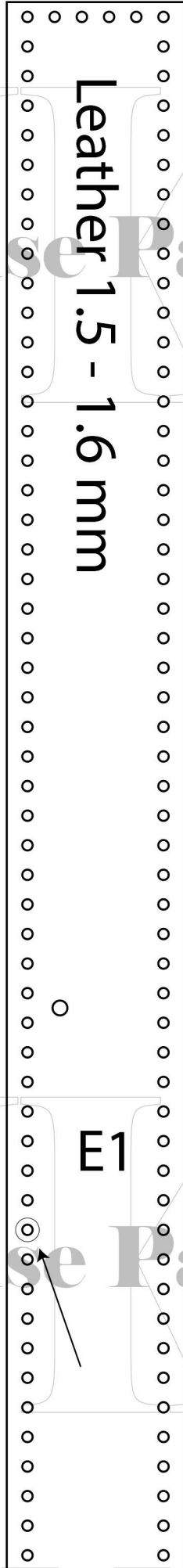
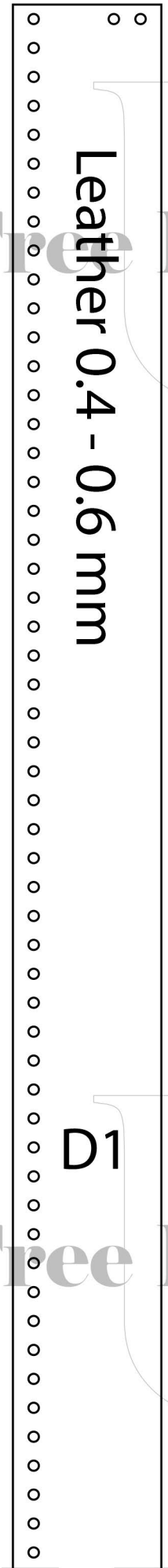



190 mm

Size 56 cm

Visor

Tree House Patterns

D2

E2

277 mm

Tree House Patterns

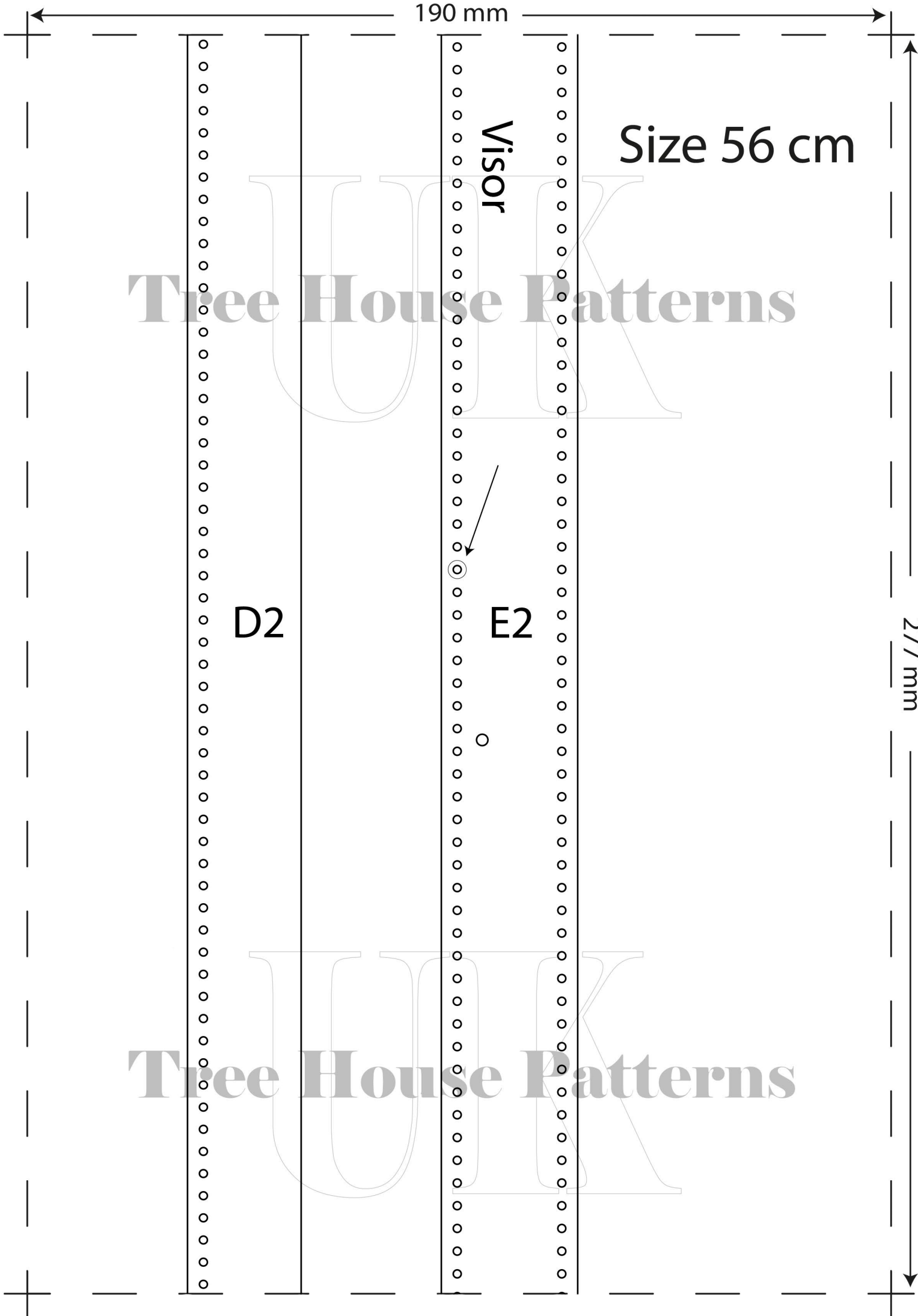

190 mm

D3

E3

Size 56 cm

Tree House Patterns

Leather 1.8 - 2.0 mm

277 mm

Tree House Patterns

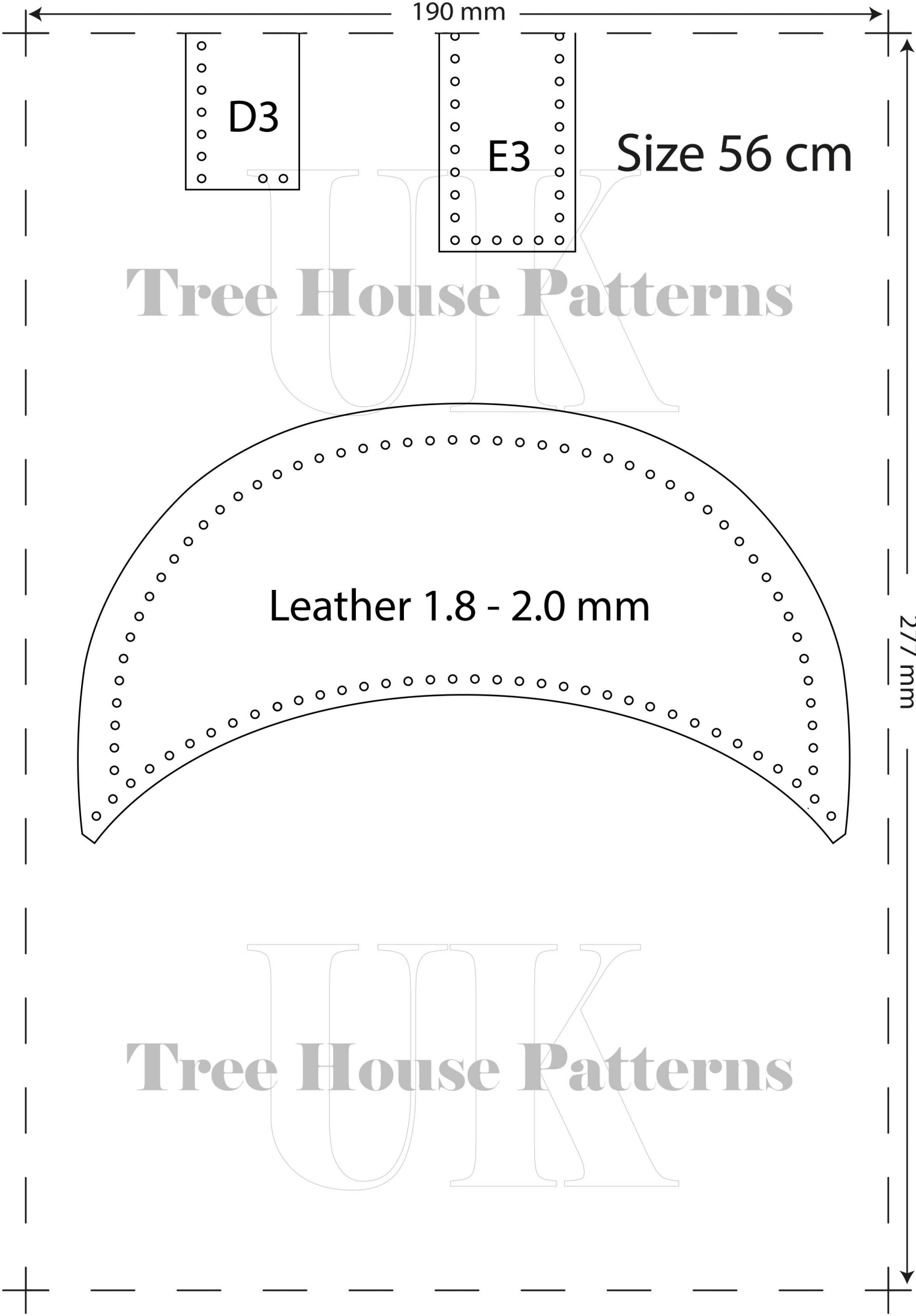

190 mm

Size 57 cm

# Tree House Patterns

The circumference of the top of the cap is larger than that of the gusset, and the holes for the threads are further apart.

Therefore , for this project , use soft leather for the top and gusset which will drape well . We used water buffalo leather with a thickness of 1.3 - 1.5 mm.

In this cap size, the thread passes from the top of the cap between part A and part B. (red mark on the pattern)

277 mm

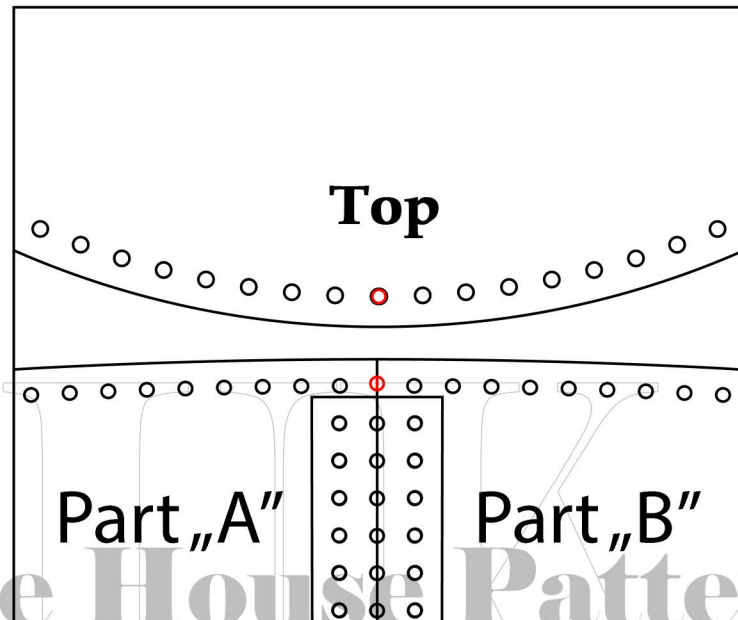

Tree House Patterns

190 mm

Size 57 cm

Tree House Patterns

Soft leather 1.3 - 1.5 mm

C1

277 mm

Tree House Patterns

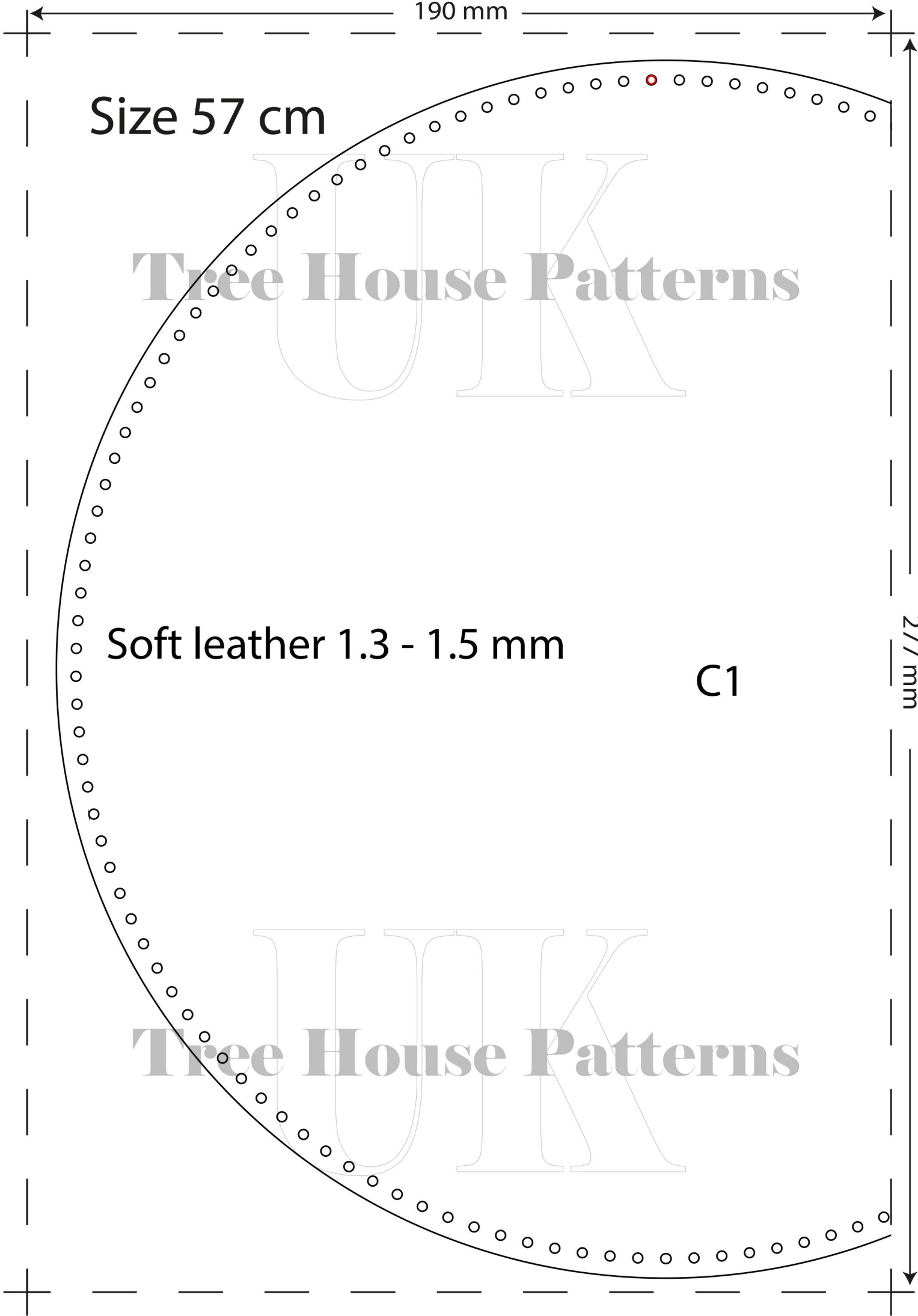

190 mm

277 mm

Tree House Patterns

Tree House Patterns

Size 57 cm

C2

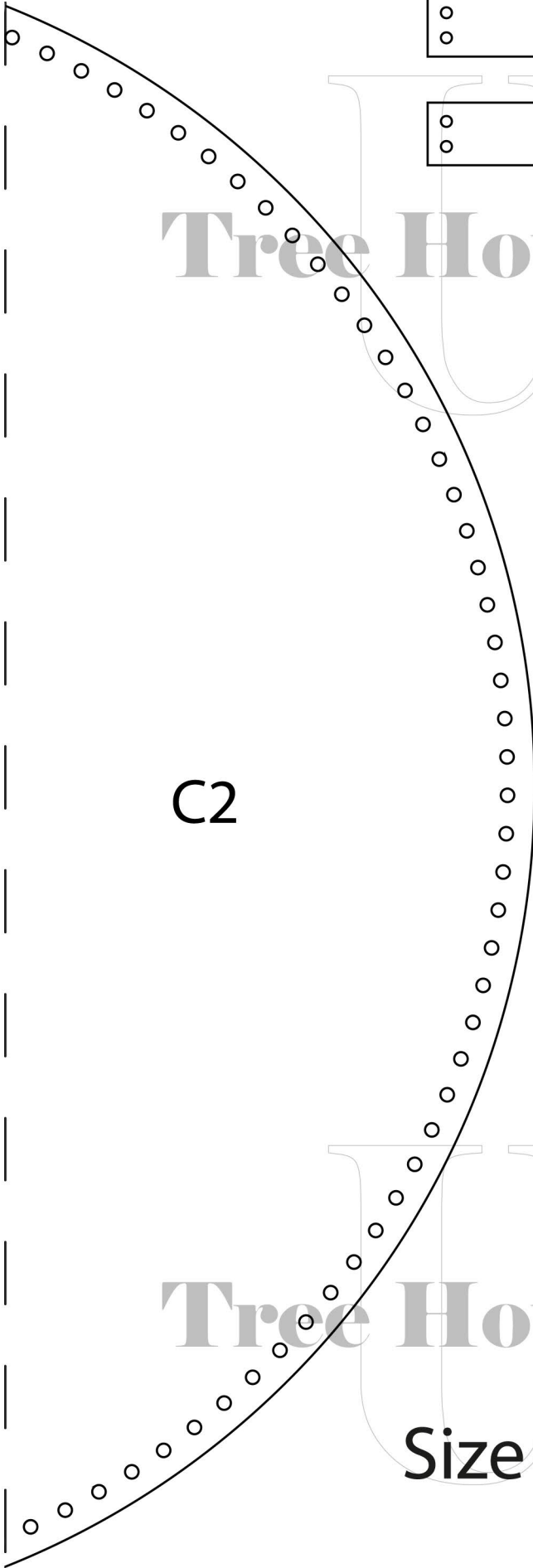
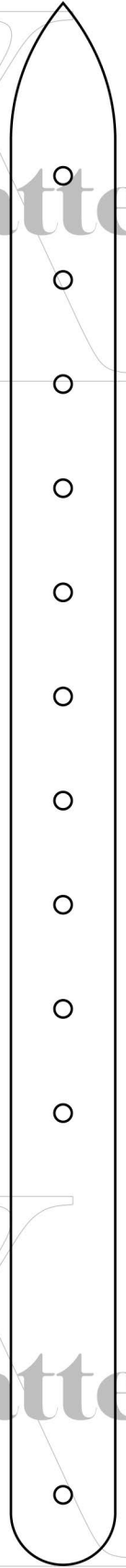
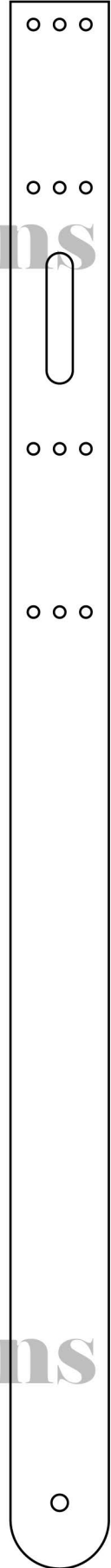
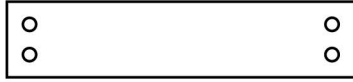

190 mm

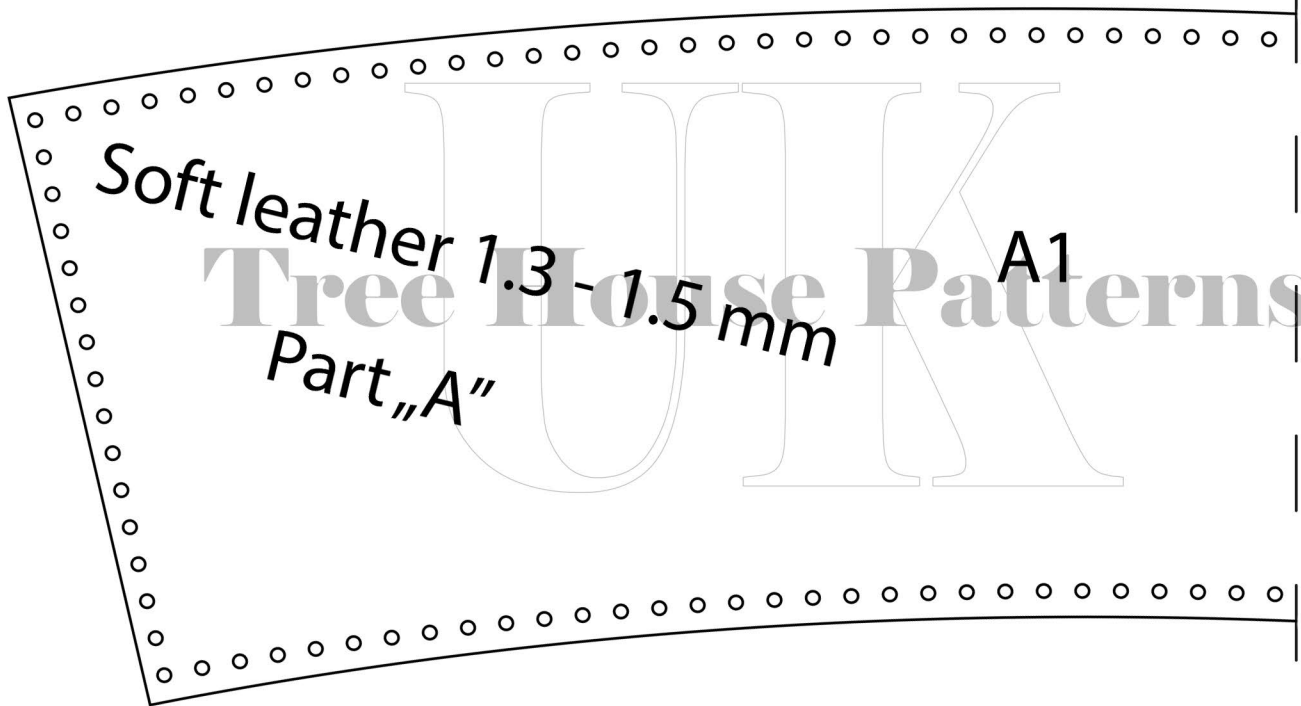

Size 57 cm

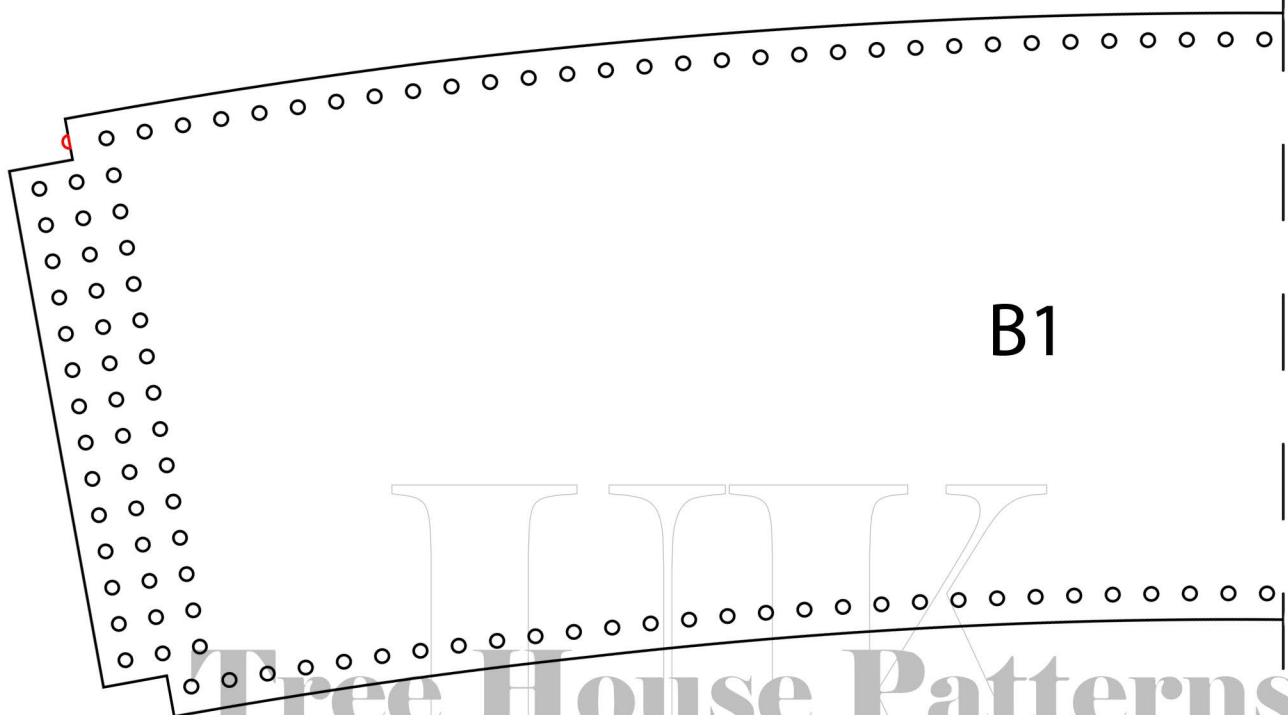

277 mm

190 mm

A2

Tree House Patterns

Size 57 cm

B2

Soft leather 1.3 - 1.5 mm  
Part „B”

Tree House Patterns

277 mm

190 mm

Size 57 cm

Leather 0.4 - 0.6 mm

Leather 1.5 - 1.6 mm

D1

E1

277 mm

Tree House Patterns

Tree House Patterns

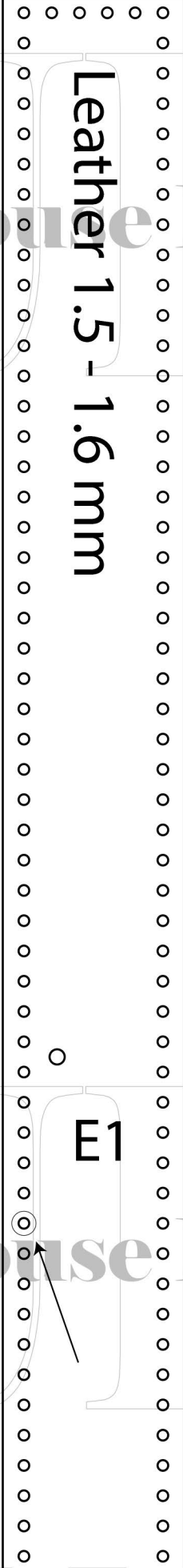
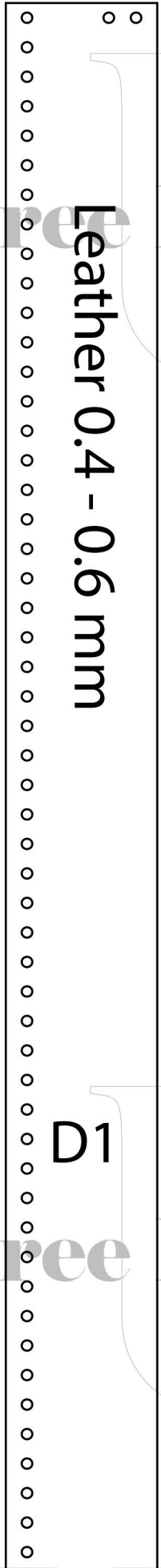



190 mm

Size 57 cm

Visor

D2

E2

277 mm

Tree House Patterns

Tree House Patterns

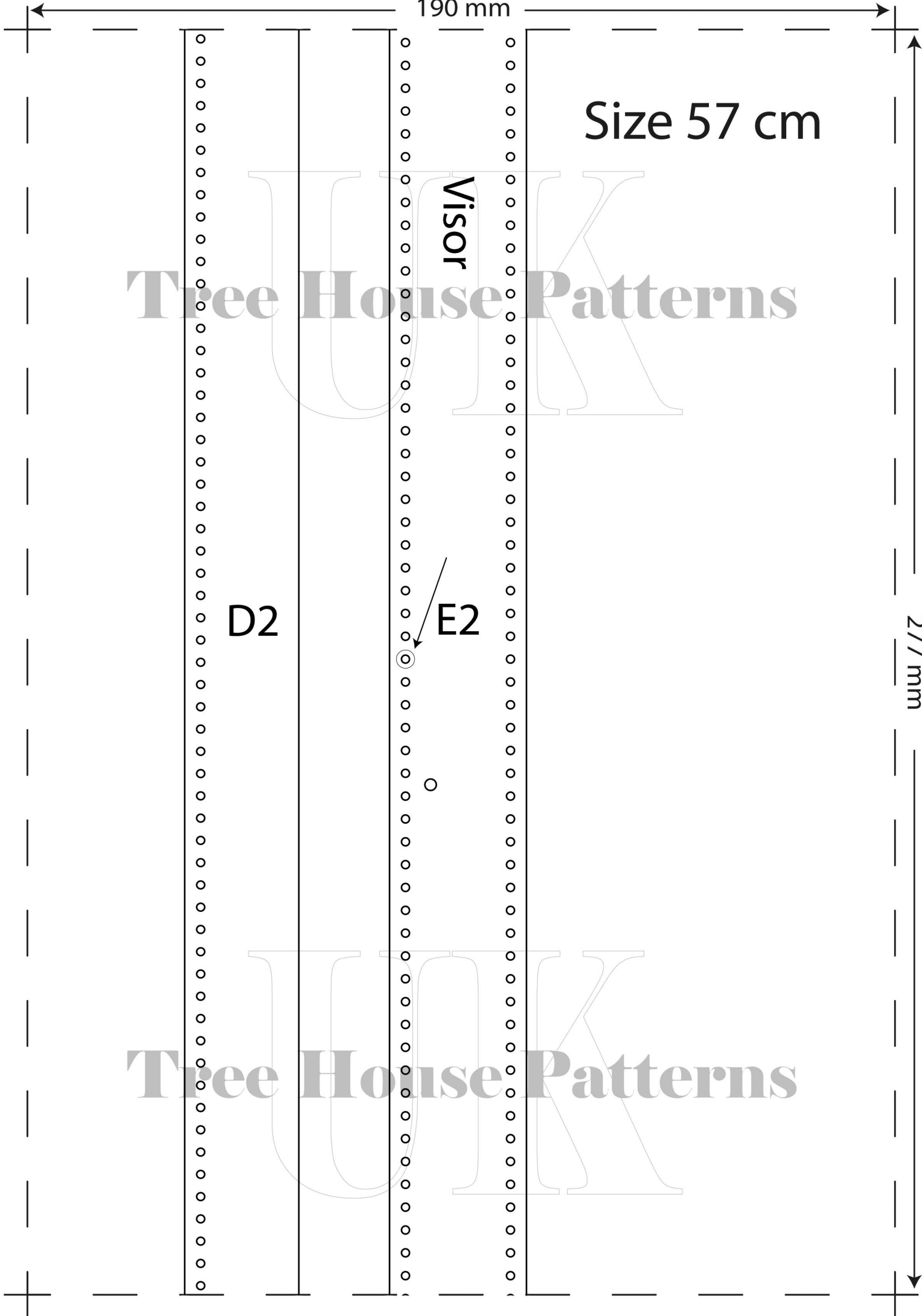

190 mm

D3

E3

Size 57 cm

Tree House Patterns

Leather 1.8 - 2.0 mm

277 mm

Tree House Patterns

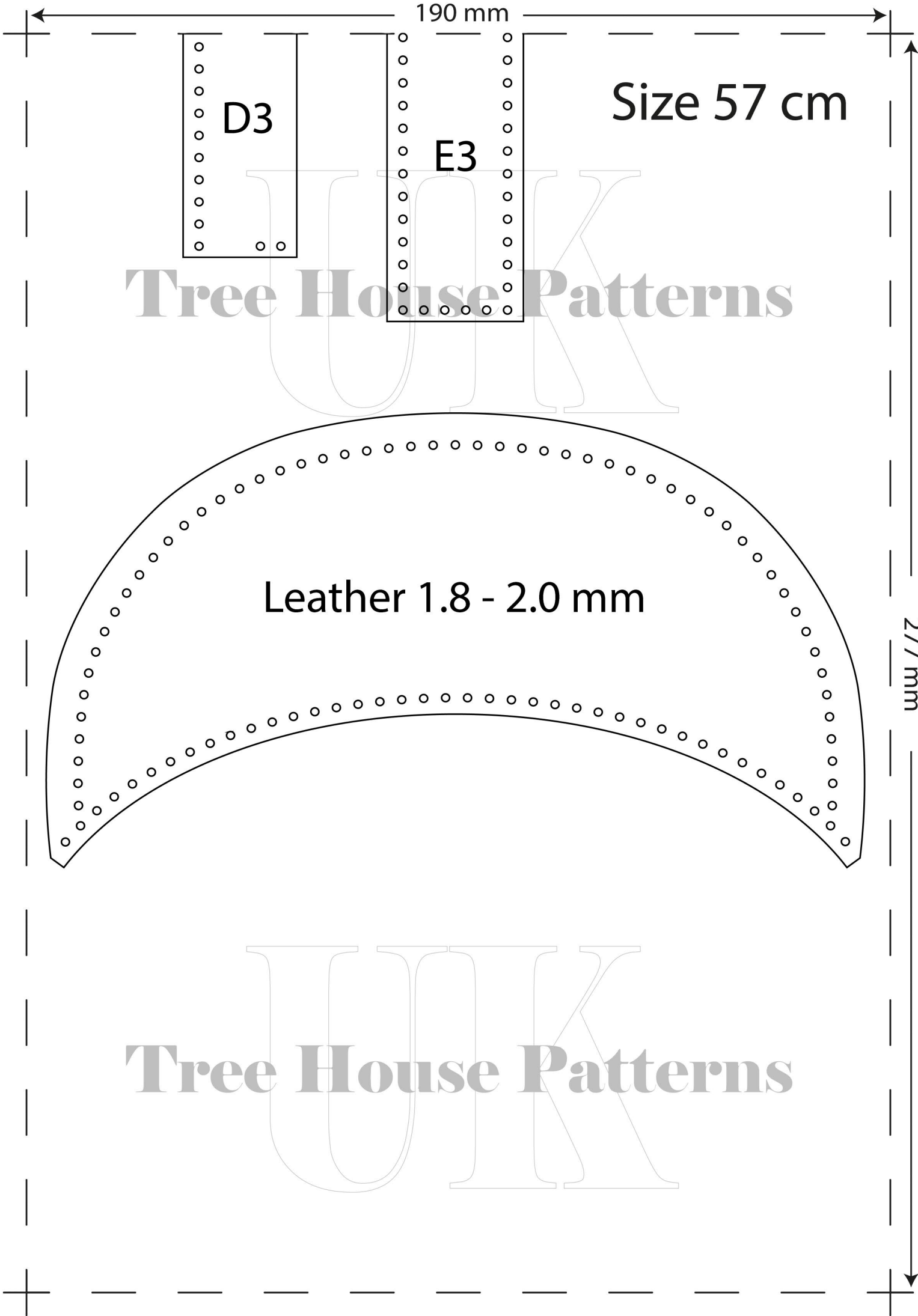

190 mm

Size 58 cm

# Tree House Patterns

The circumference of the top of the cap is larger than that of the gusset, and the holes for the threads are further apart.

Therefore, for this project, use soft leather for the top and gusset which will drape well. We used water buffalo leather with a thickness of 1.3 - 1.5 mm.

**In this size of the cap, sewing is done in the normal way (red points on the pattern are for preview only)**

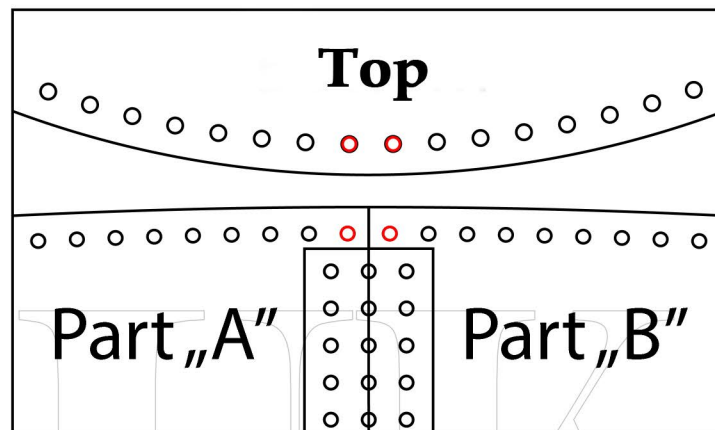

# Tree House Patterns

277 mm

190 mm

Size 58 cm

Tree House Patterns

Soft leather 1.3 - 1.5 mm

C1

277 mm

Tree House Patterns

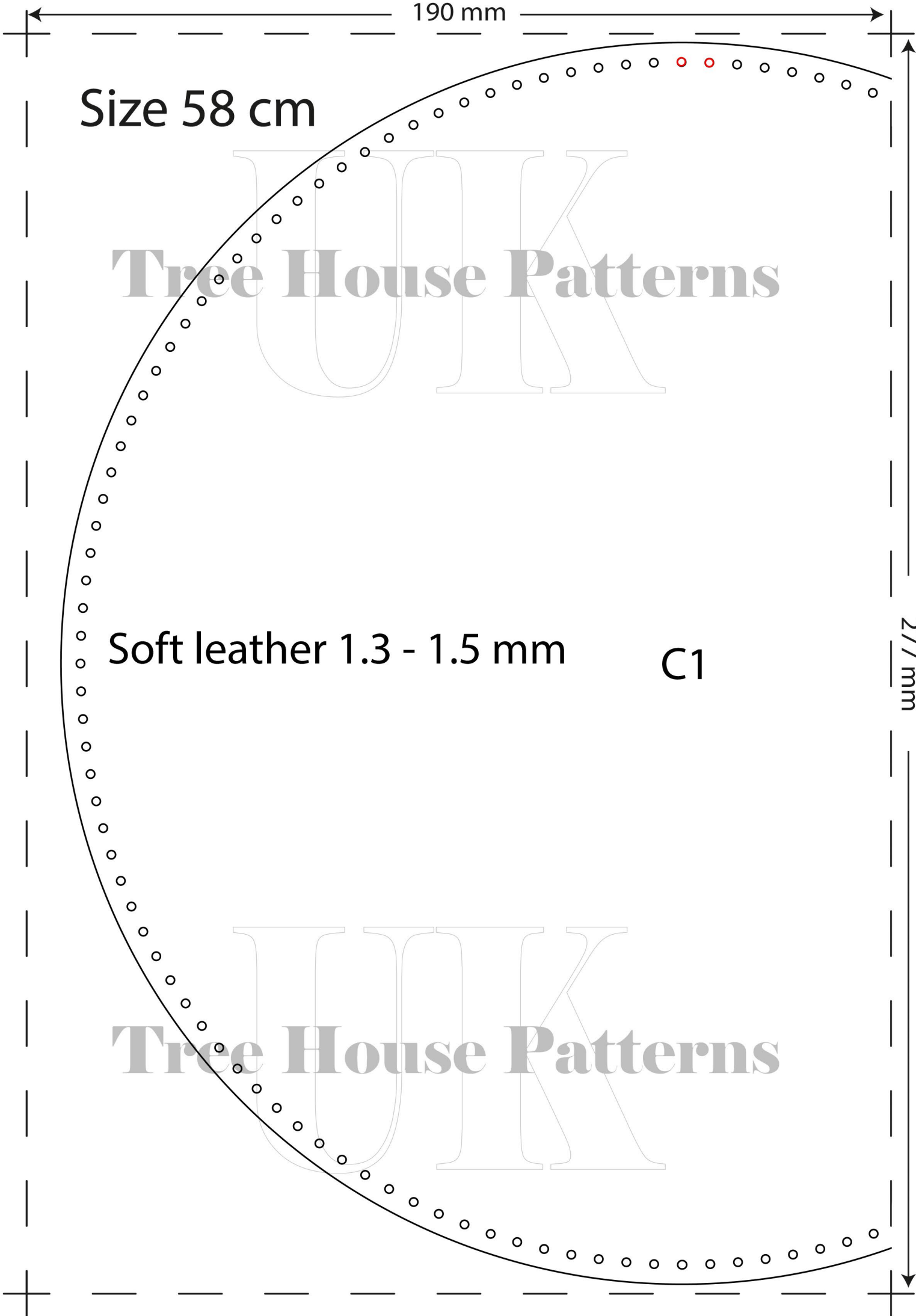

190 mm

277 mm

C2

Size 58 cm

Tree House Patterns

Tree House Patterns

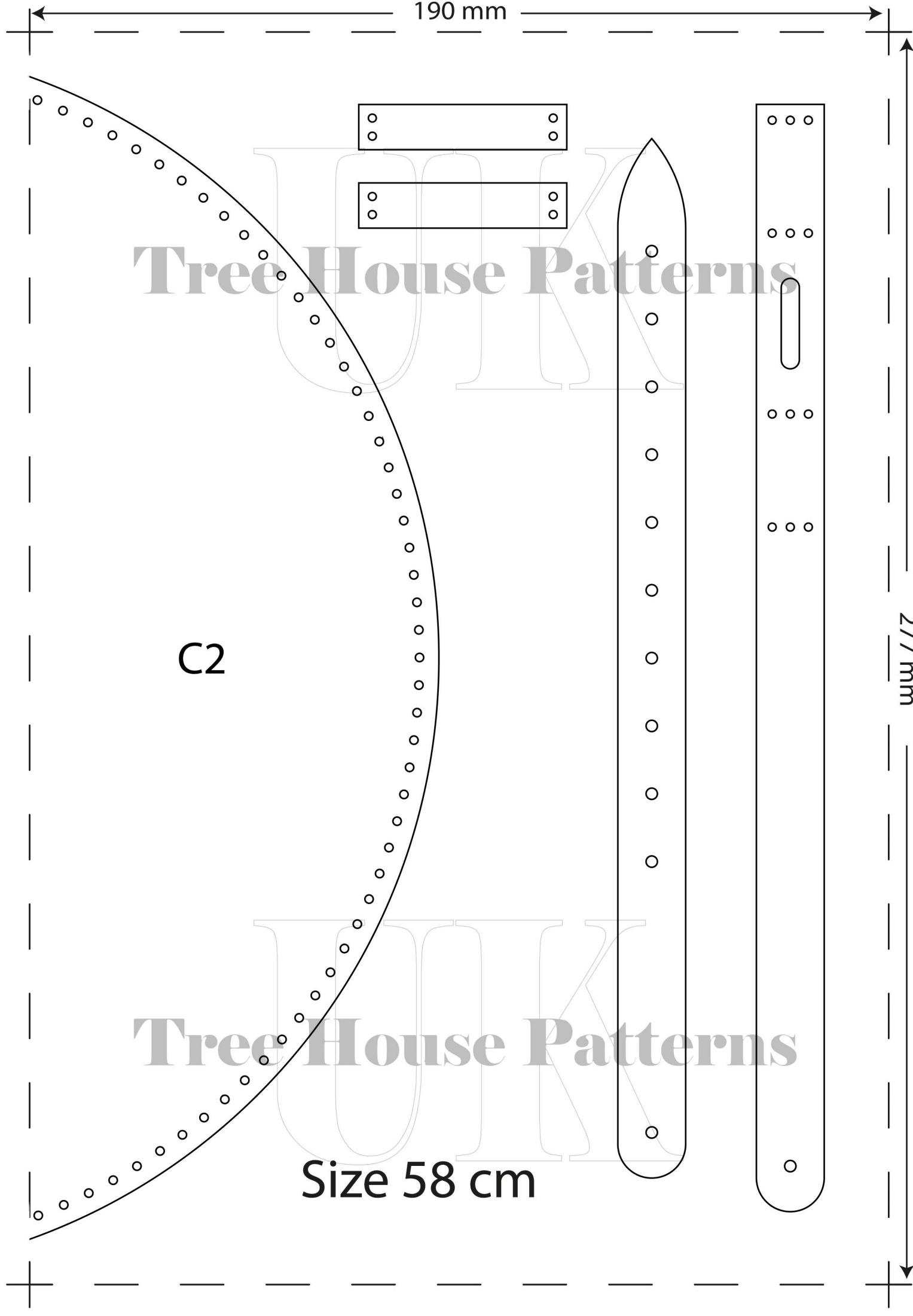

190 mm

Size 58 cm

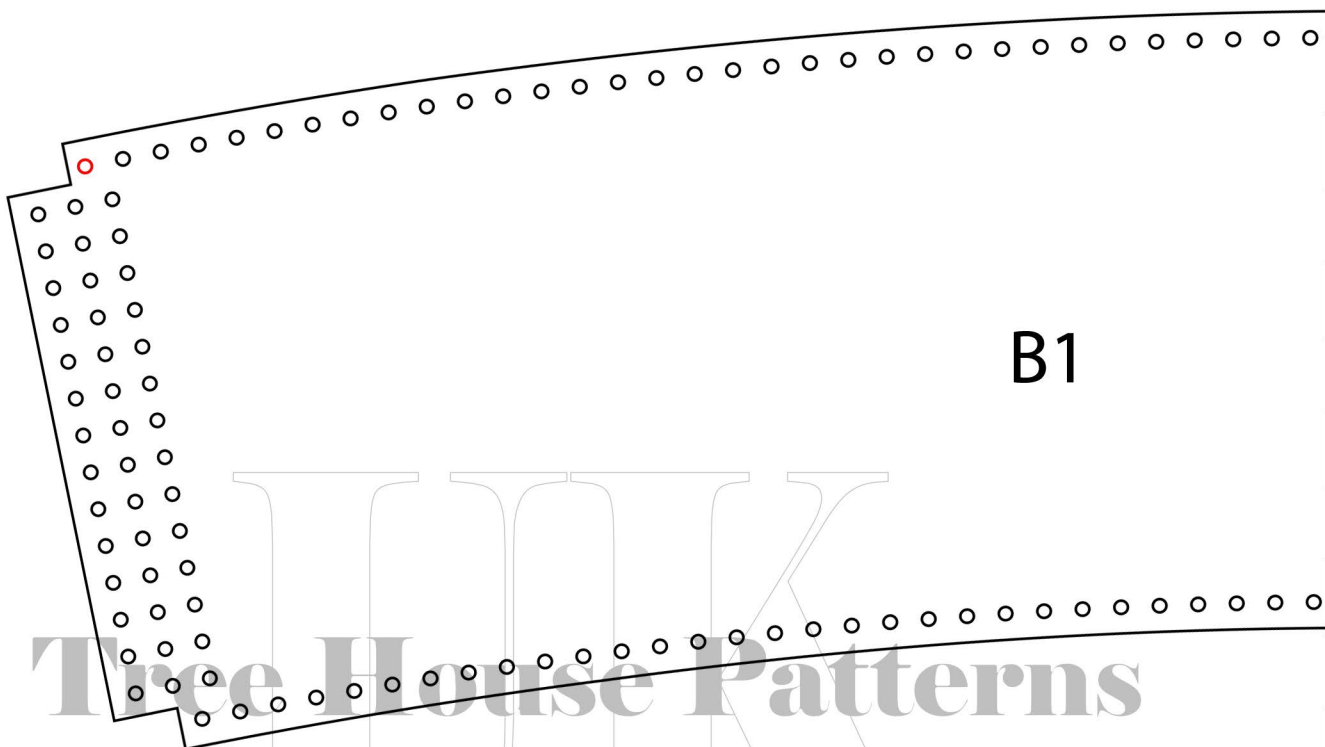
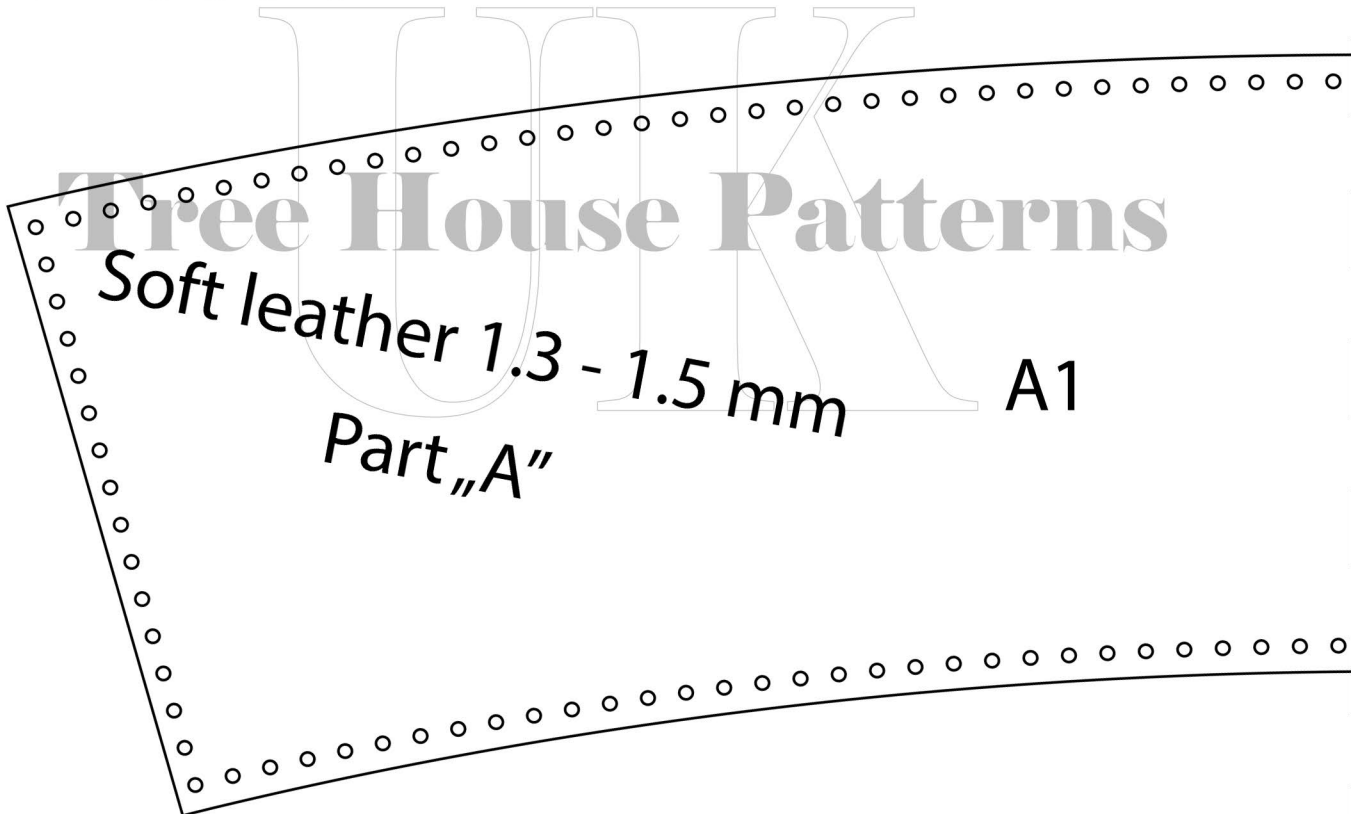

277 mm

190 mm

# Tree House Patterns

A2

277 mm

Soft leather 1.3 - 1.5 mm  
Part „B“

B2

# Tree House Patterns

Size 58 cm

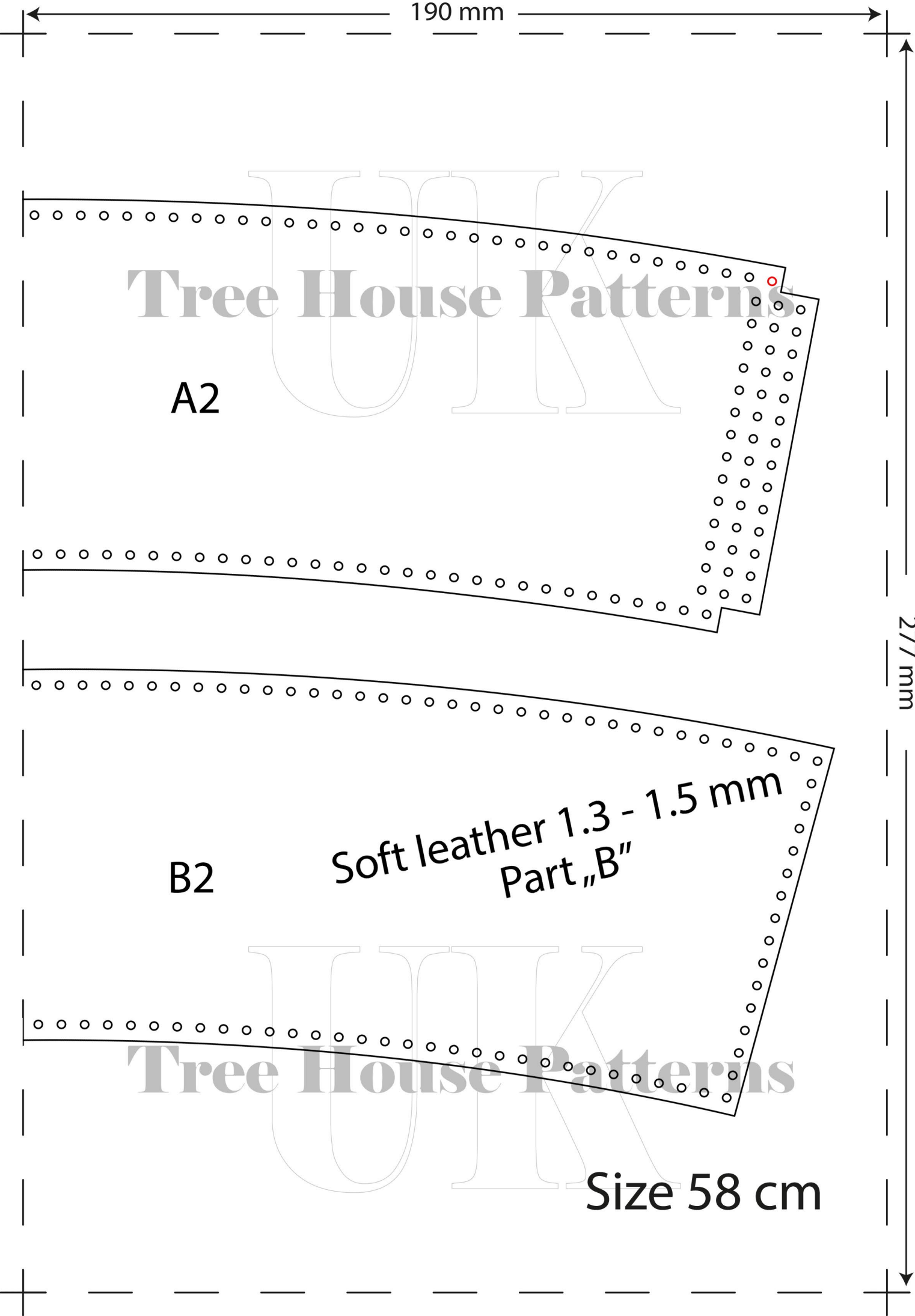

190 mm

Size 58 cm

Leather 0.4 - 0.6 mm

Leather 1.5 - 1.6 mm

F1

D1

277 mm

Tree House Patterns

Tree House Patterns

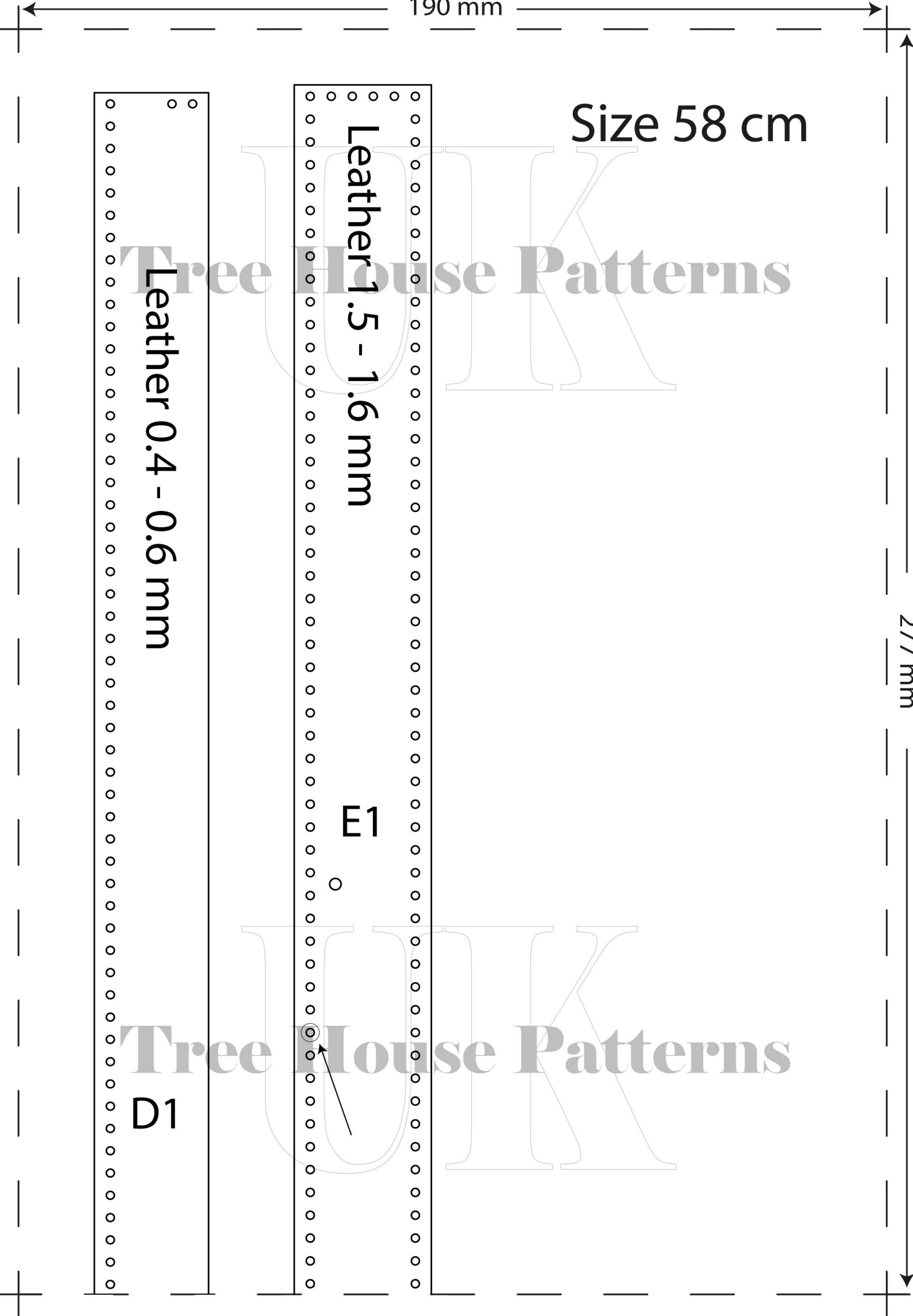



190 mm

Size 58 cm

Visor

Tree House Patterns

D2

E2

277 mm

Tree House Patterns

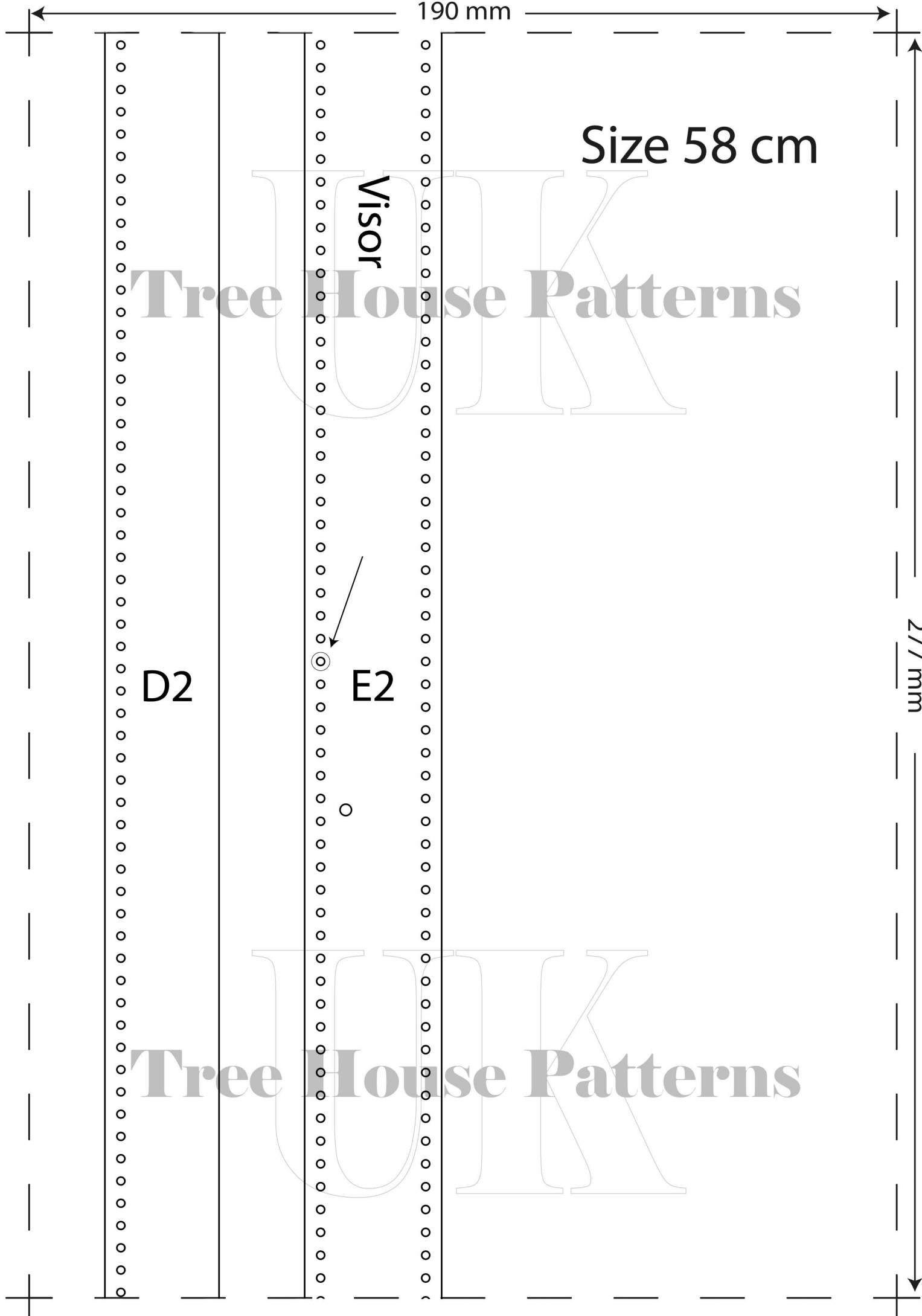

190 mm

D3

E3

Size 58 cm

Tree House Patterns

Leather 1.8 - 2.0 mm

277 mm

Tree House Patterns

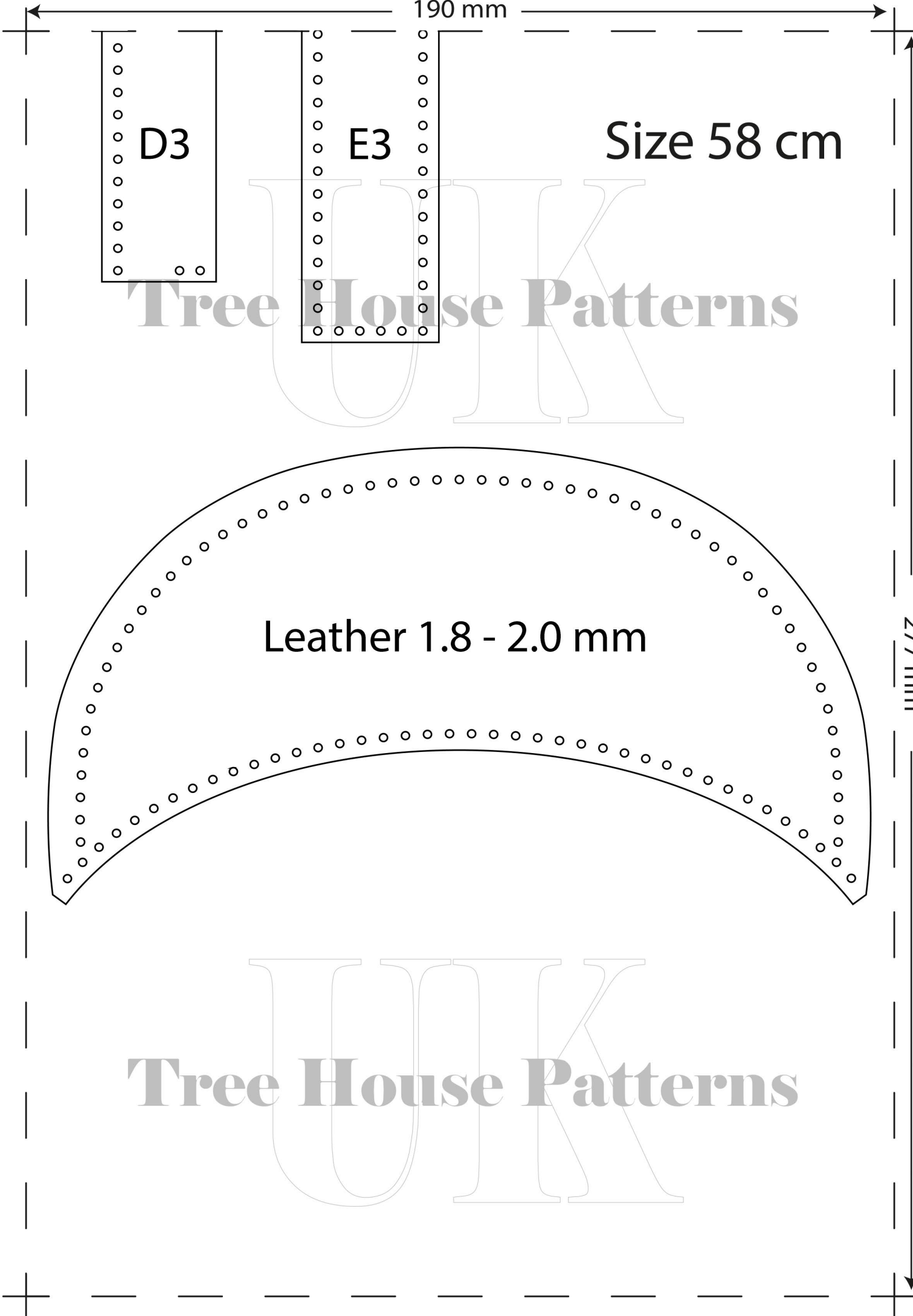

190 mm

Size 59 cm

# Tree House Patterns

**The circumference of the top of the cap is larger than that of the gusset, and the holes for the threads are further apart.**

**Therefore , for this project , use soft leather for the top and gusset which will drape well . We used water buffalo leather with a thickness of 1.3 - 1.5 mm.**

**In this size of the cap, sewing is done in the normal way (red points on the pattern are for preview only)**

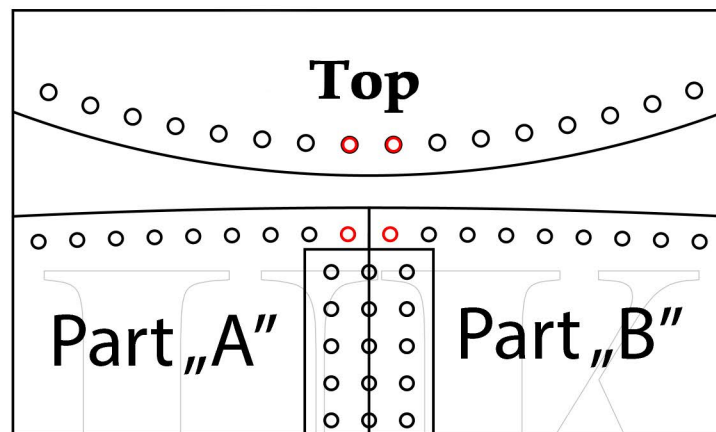

# Tree House Patterns

277 mm

190 mm

Size 59 cm

Tree House Patterns

Soft leather 1.3 - 1.5 mm

C1

277 mm

Tree House Patterns

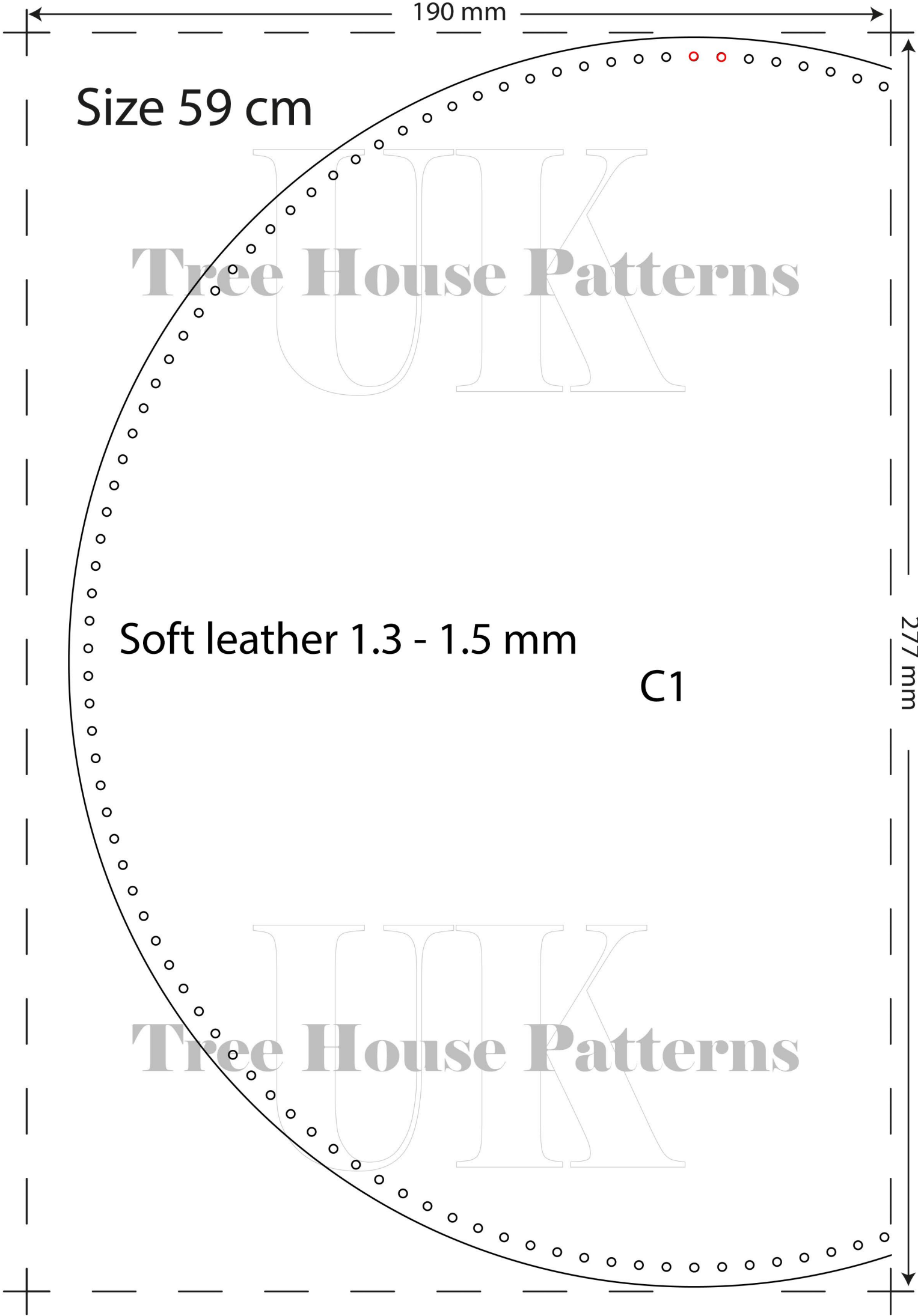

190 mm

277 mm

Tree House Patterns

Tree House Patterns

C2

Size 59 cm

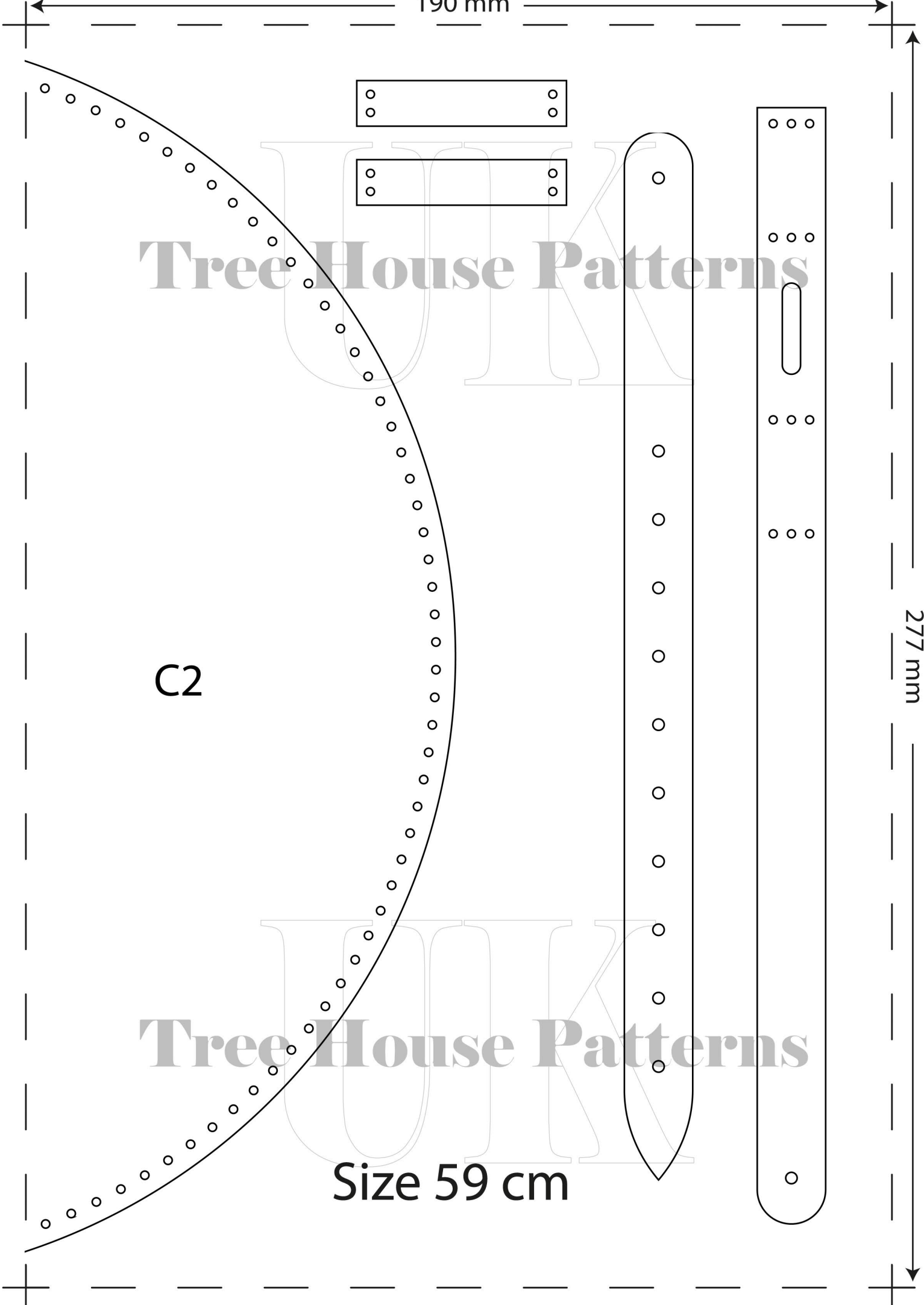

190 mm

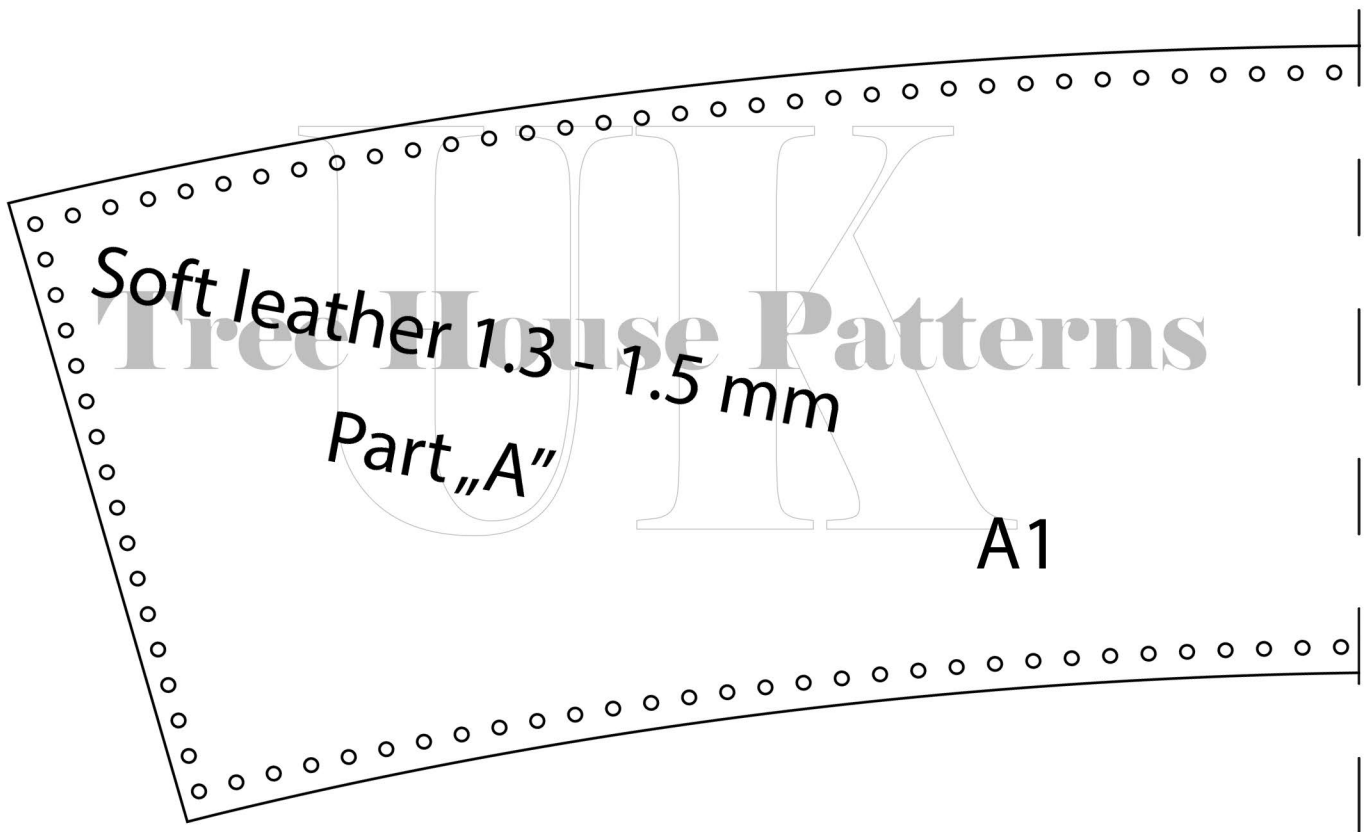

Soft leather 1.3 - 1.5 mm  
Part „A“

A1

Size 59 cm

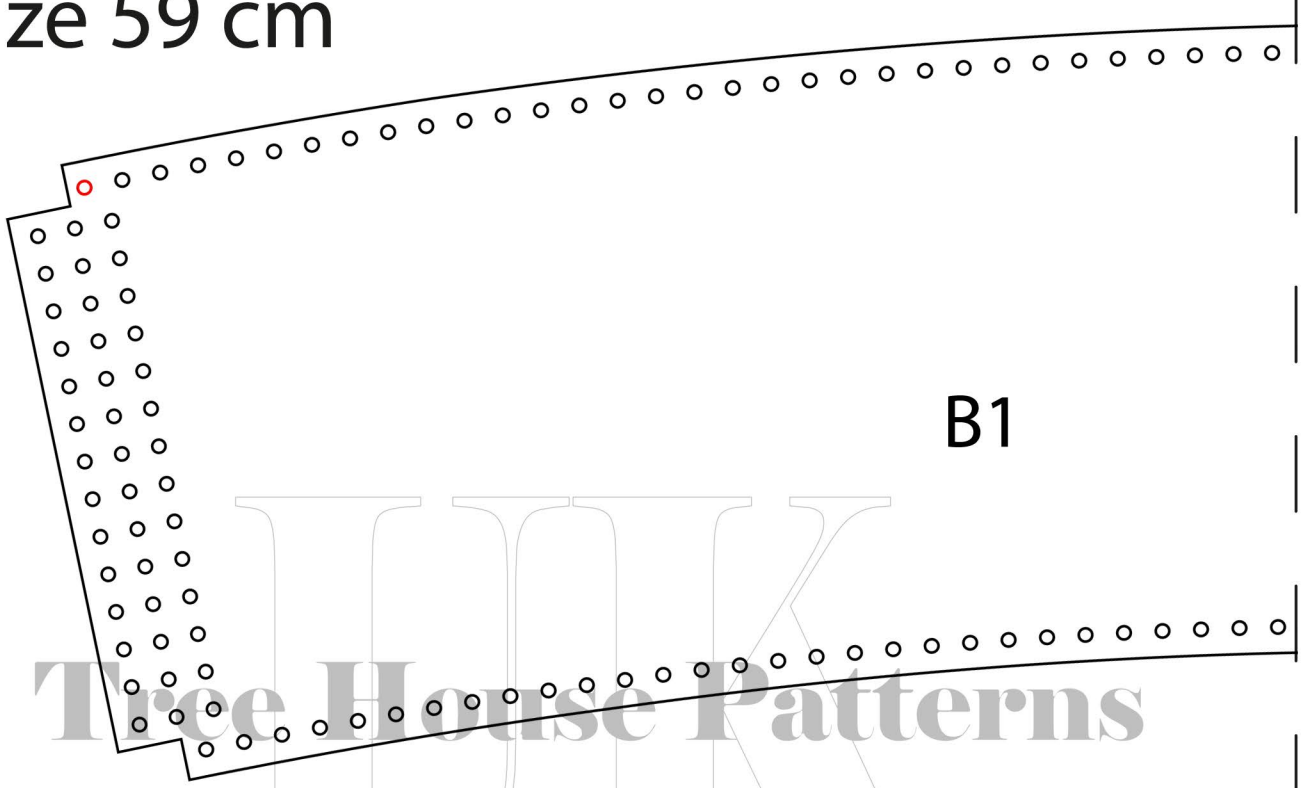

B1

277 mm

190 mm

# Tree House Patterns

A2

Size 59 cm

277 mm

Soft leather 1.3 - 1.5 mm  
Part "B"

B2

# Tree House Patterns

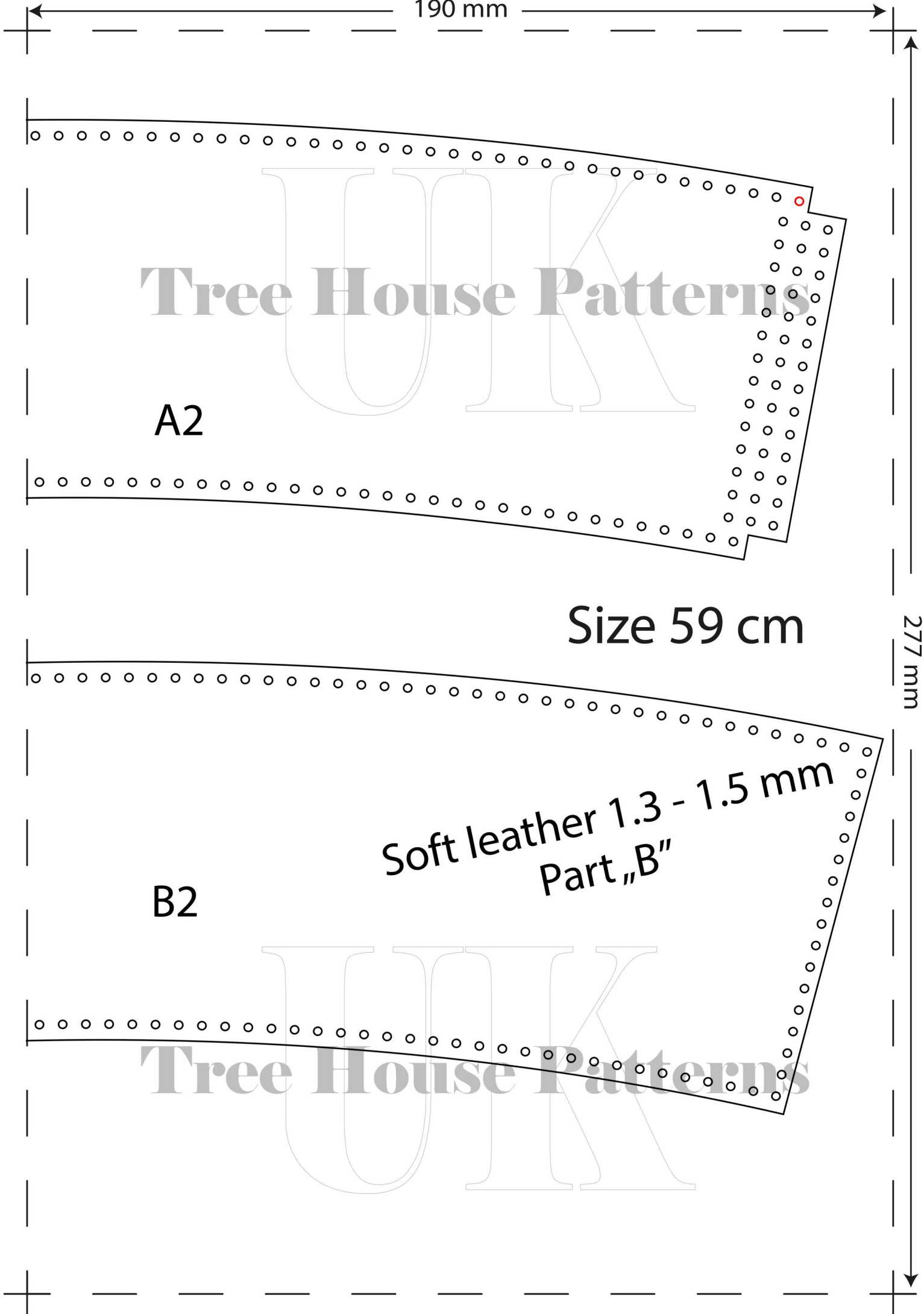

190 mm

277 mm

Size 59 cm

Leather 0.4 - 0.6 mm

Leather 1.5 - 1.6 mm

E1

D1

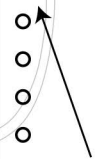

Tree House Patterns

Tree House Patterns



190 mm

Size 59 cm

Tree House Patterns

Visor

D2

E2

277 mm

Tree House Patterns

7

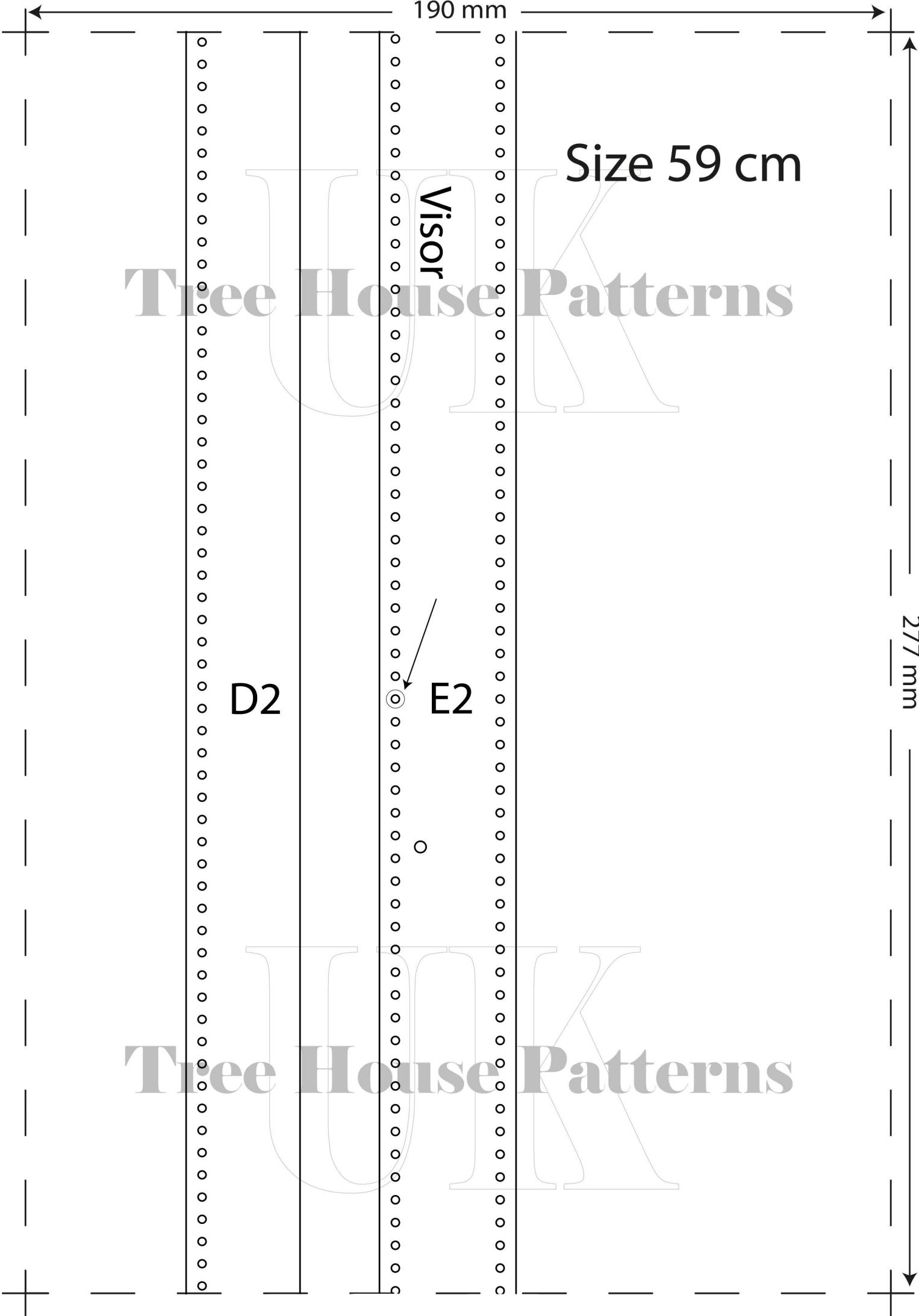

190 mm

Size 59 cm

D3

E3

Tree House Patterns

277 mm

Leather 1.8 - 2.0 mm

Tree House Patterns

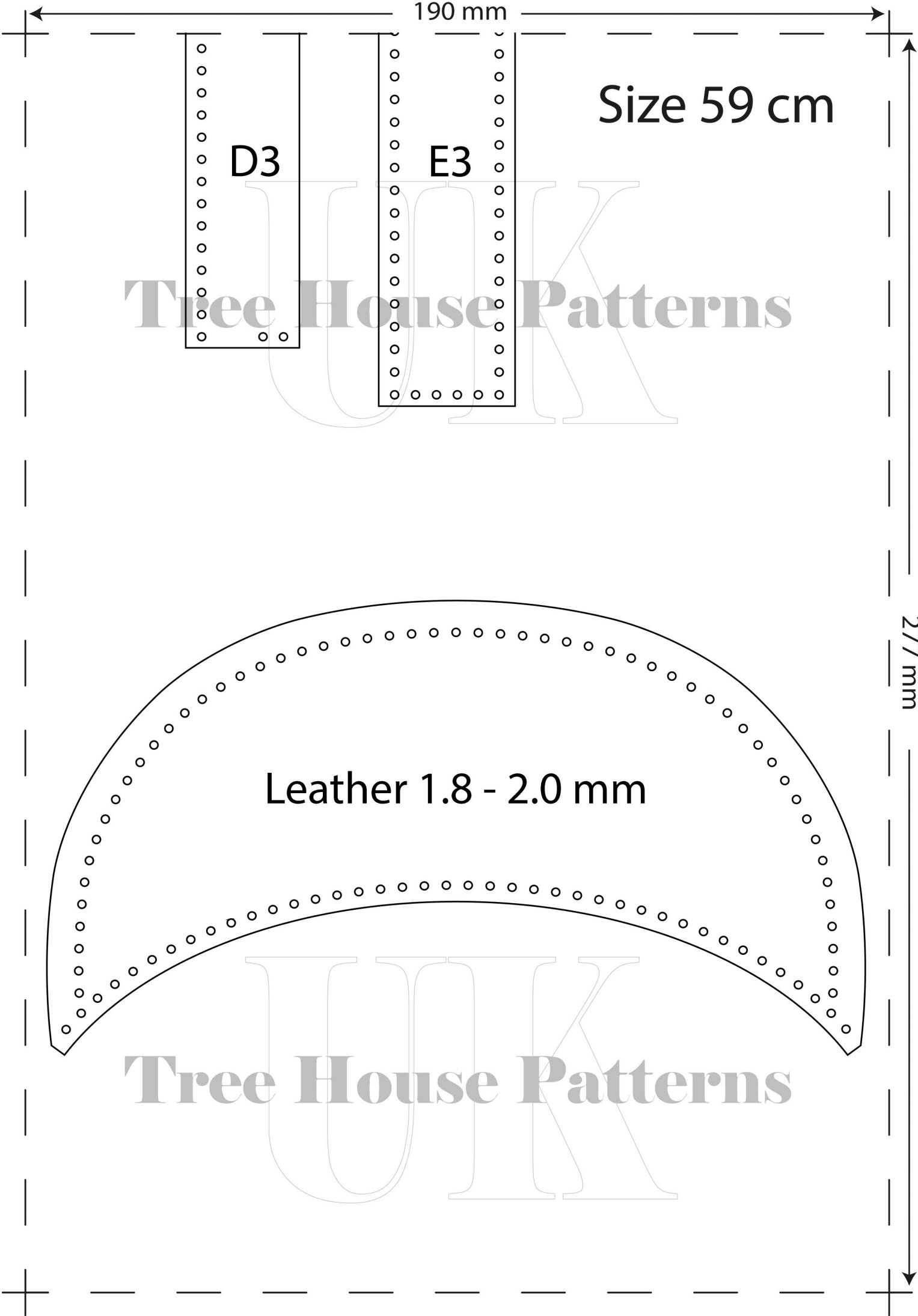

190 mm

Size 60 cm

# Tree House Patterns

**The circumference of the top of the cap is larger than that of the gusset, and the holes for the threads are further apart.**

**Therefore , for this project , use soft leather for the top and gusset which will drape well . We used water buffalo leather with a thickness of 1.3 - 1.5 mm.**

**In this size of the cap, sewing is done in the normal way (red points on the pattern are for preview only)**

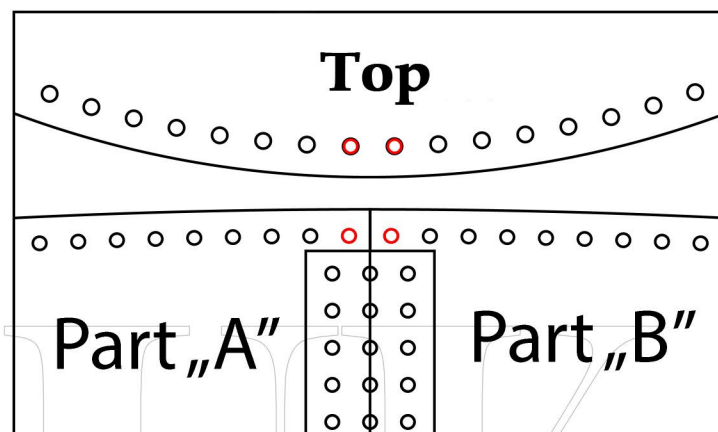

# Tree House Patterns

277 mm

190 mm

Size 60 cm

Tree House Patterns

Soft leather 1.3 - 1.5 mm

C1

Tree House Patterns

277 mm

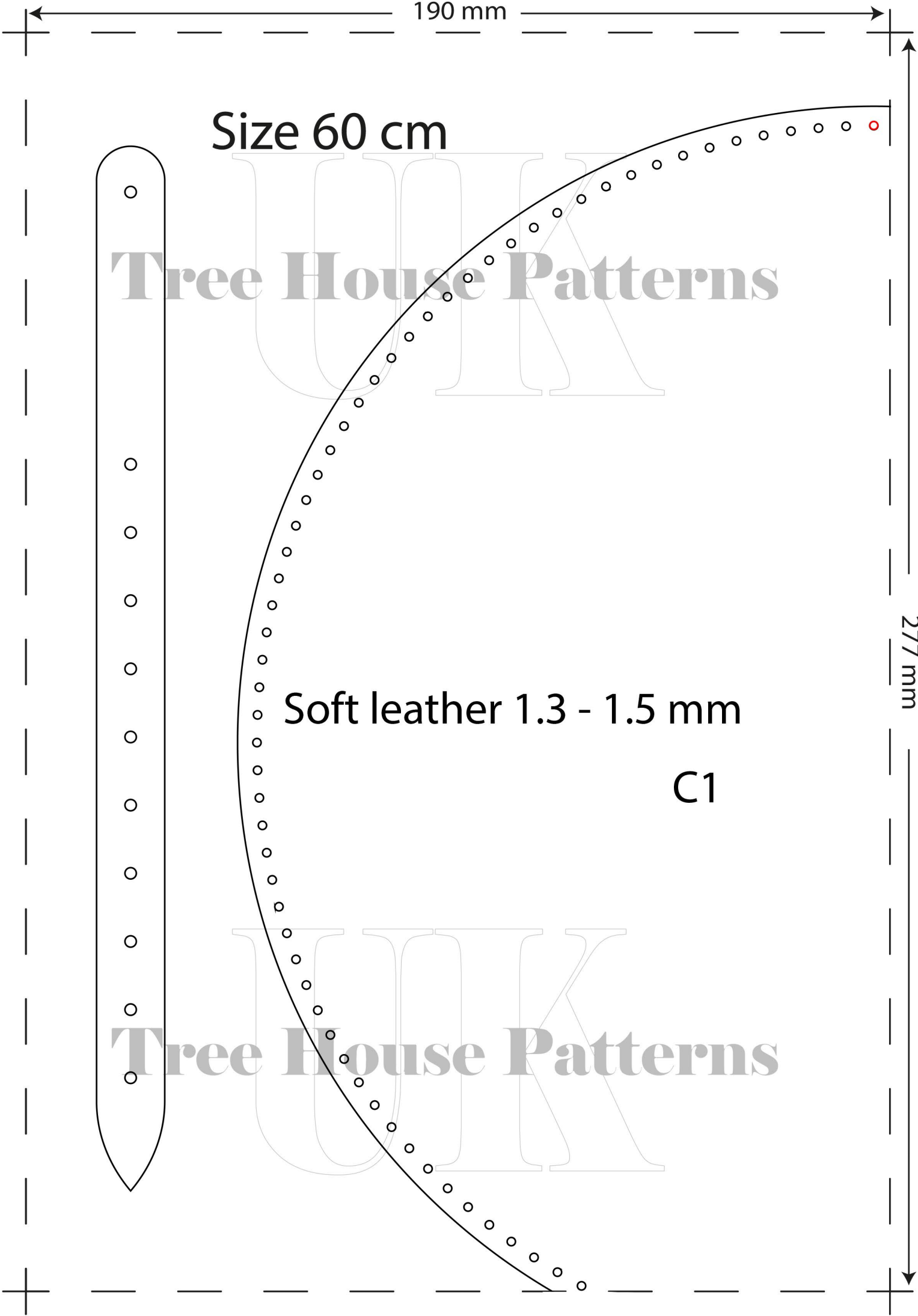

190 mm

Size 60 cm

Tree House Patterns

C2

Tree House Patterns

277 mm

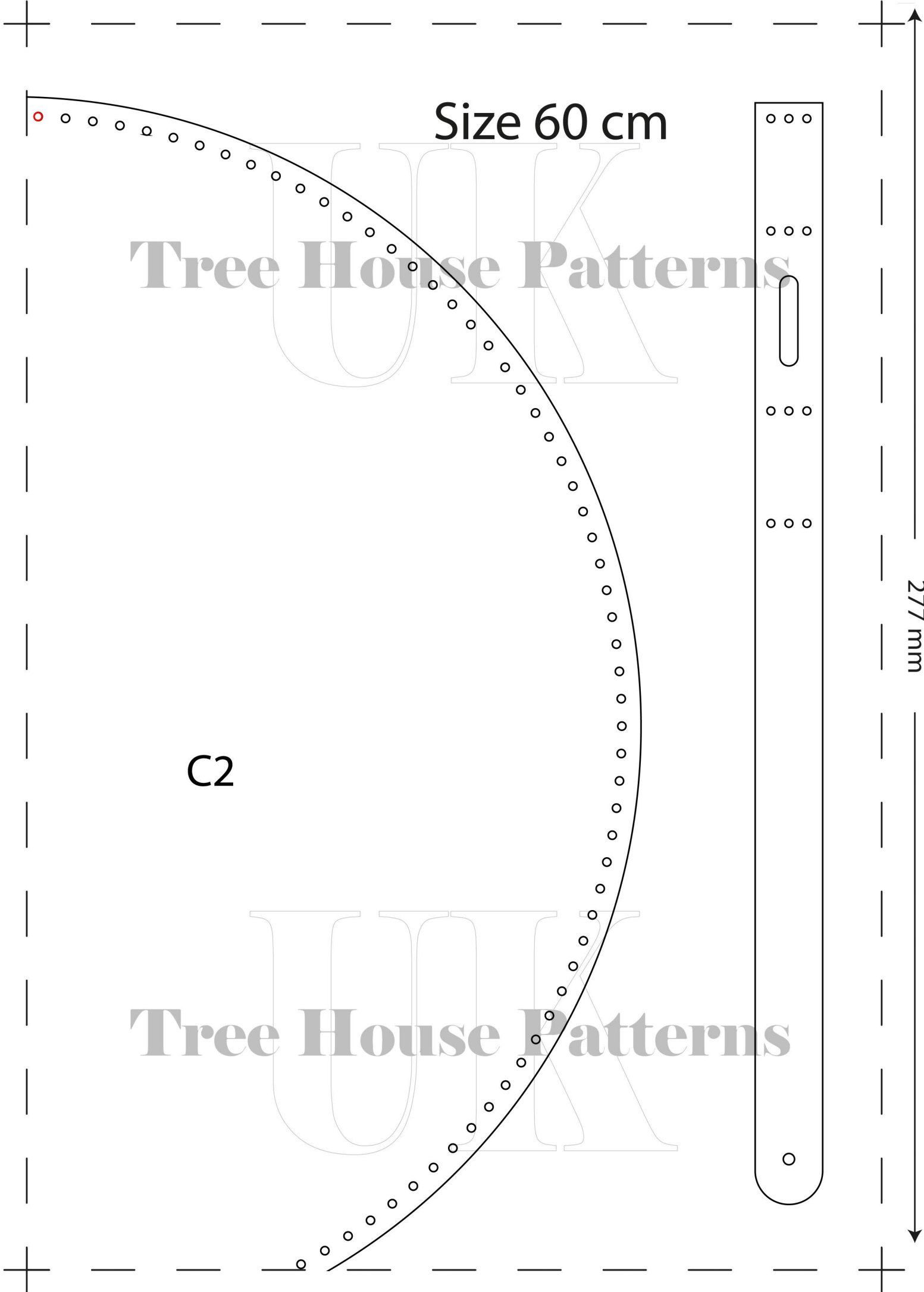

190 mm

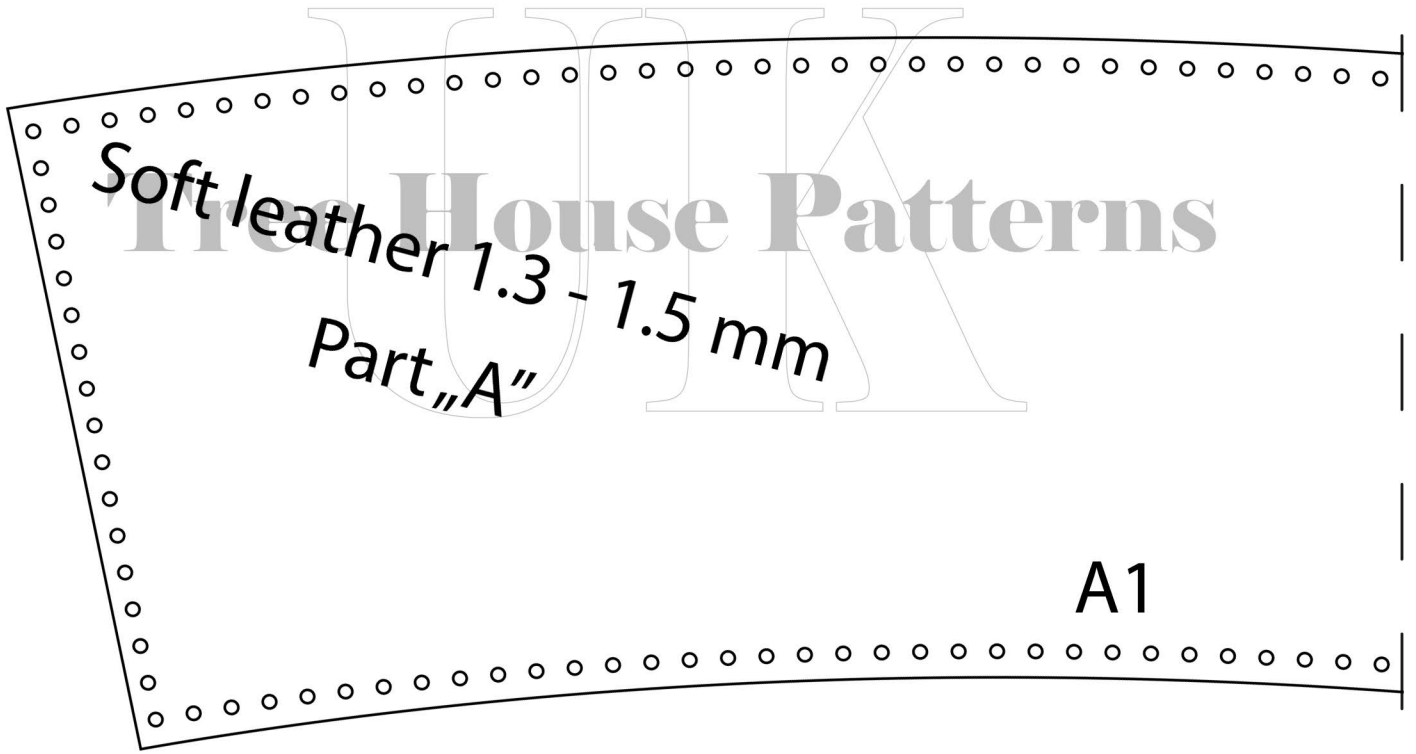

Soft leather 1.3 - 1.5 mm  
Part "A"

A1

Size 60 cm

277 mm

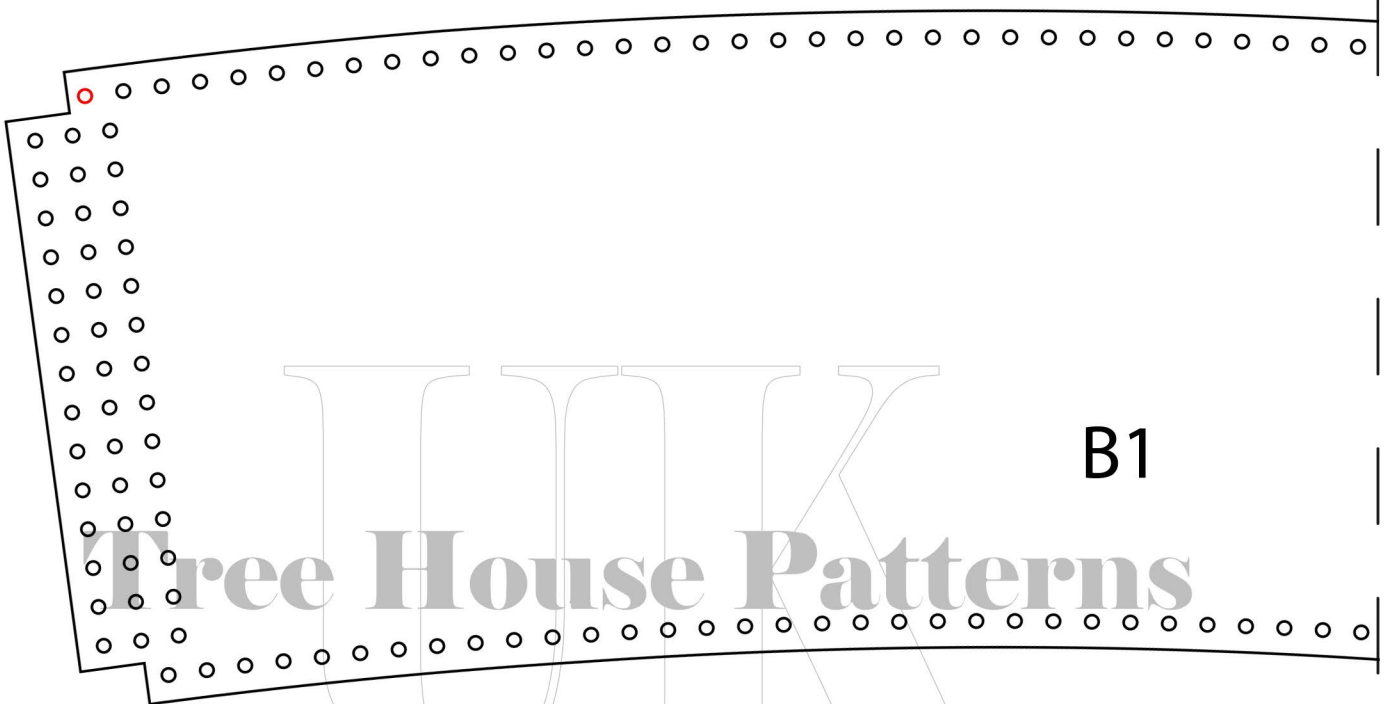

B1

Free House Patterns

190 mm

277 mm

Tree House Patterns

A2

Size 60 cm

Soft leather 1.3 - 1.5 mm  
Part "B"

B2

Tree House Patterns

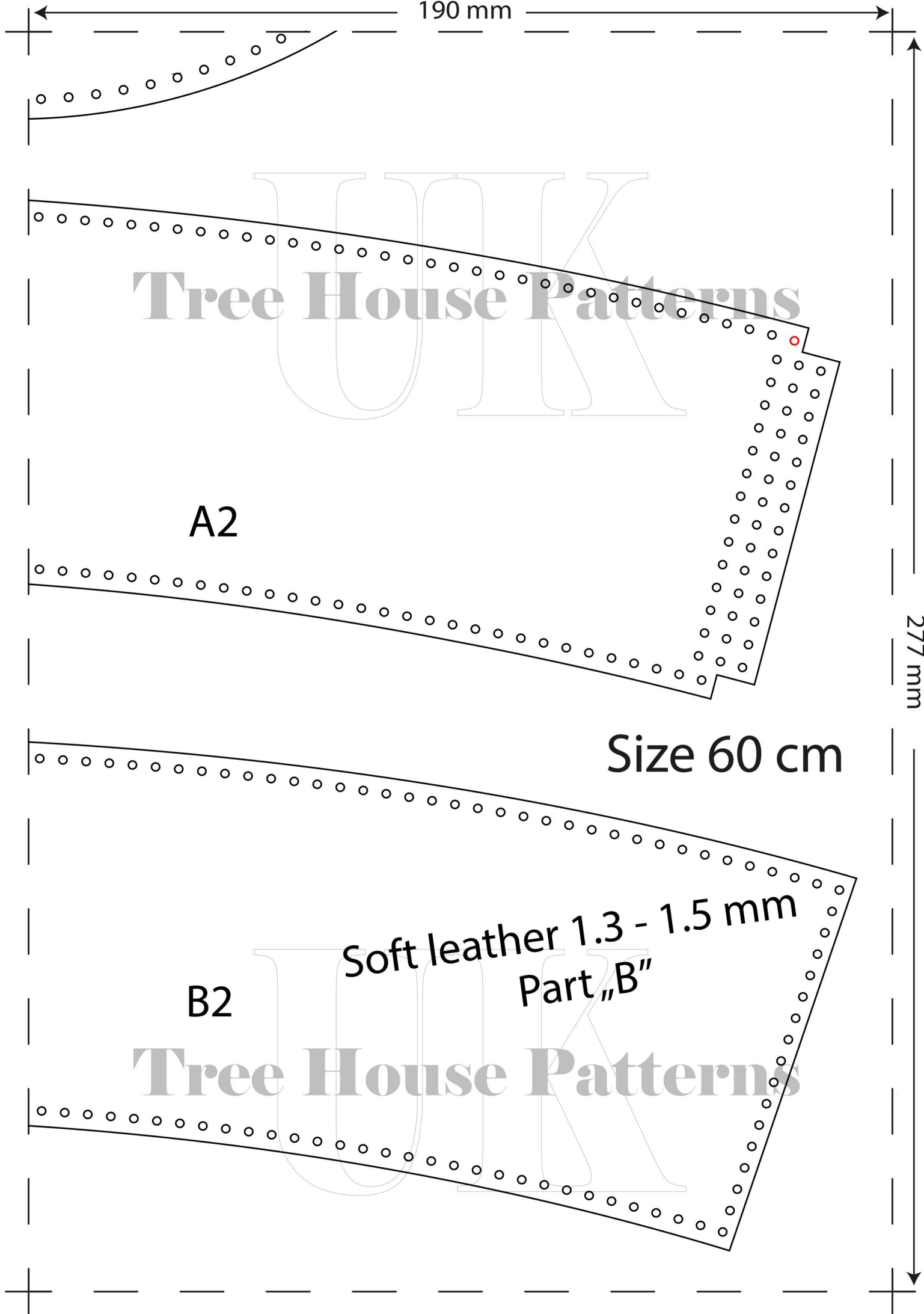

190 mm

Size 60 cm

Leather 0.4 - 0.6 mm

Leather 1.5 - 1.6 mm

D1

E1

277 mm

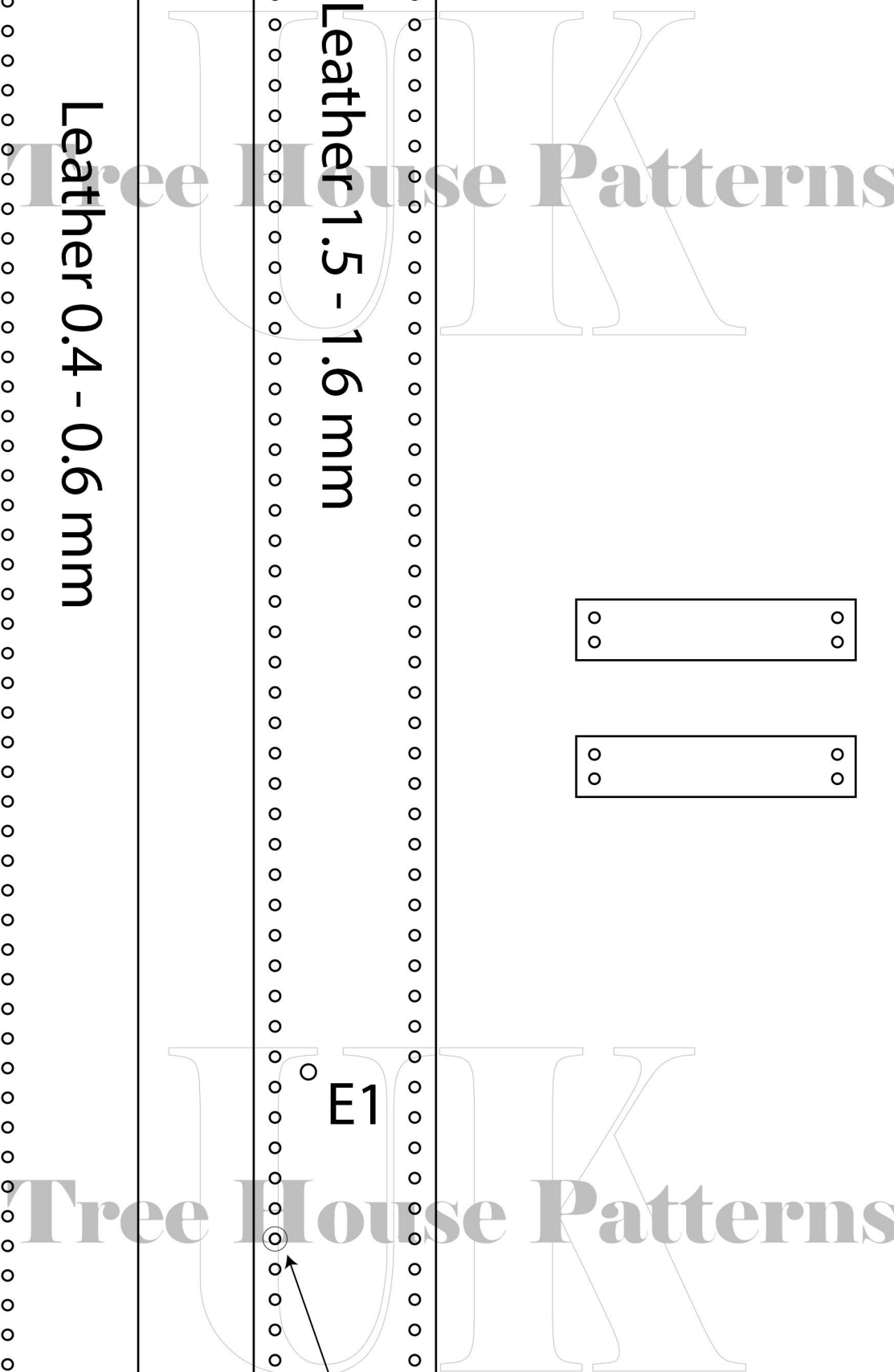



190 mm

Size 60 cm

Tree House Patterns

Visor

D2

E2

277 mm

Tree House Patterns

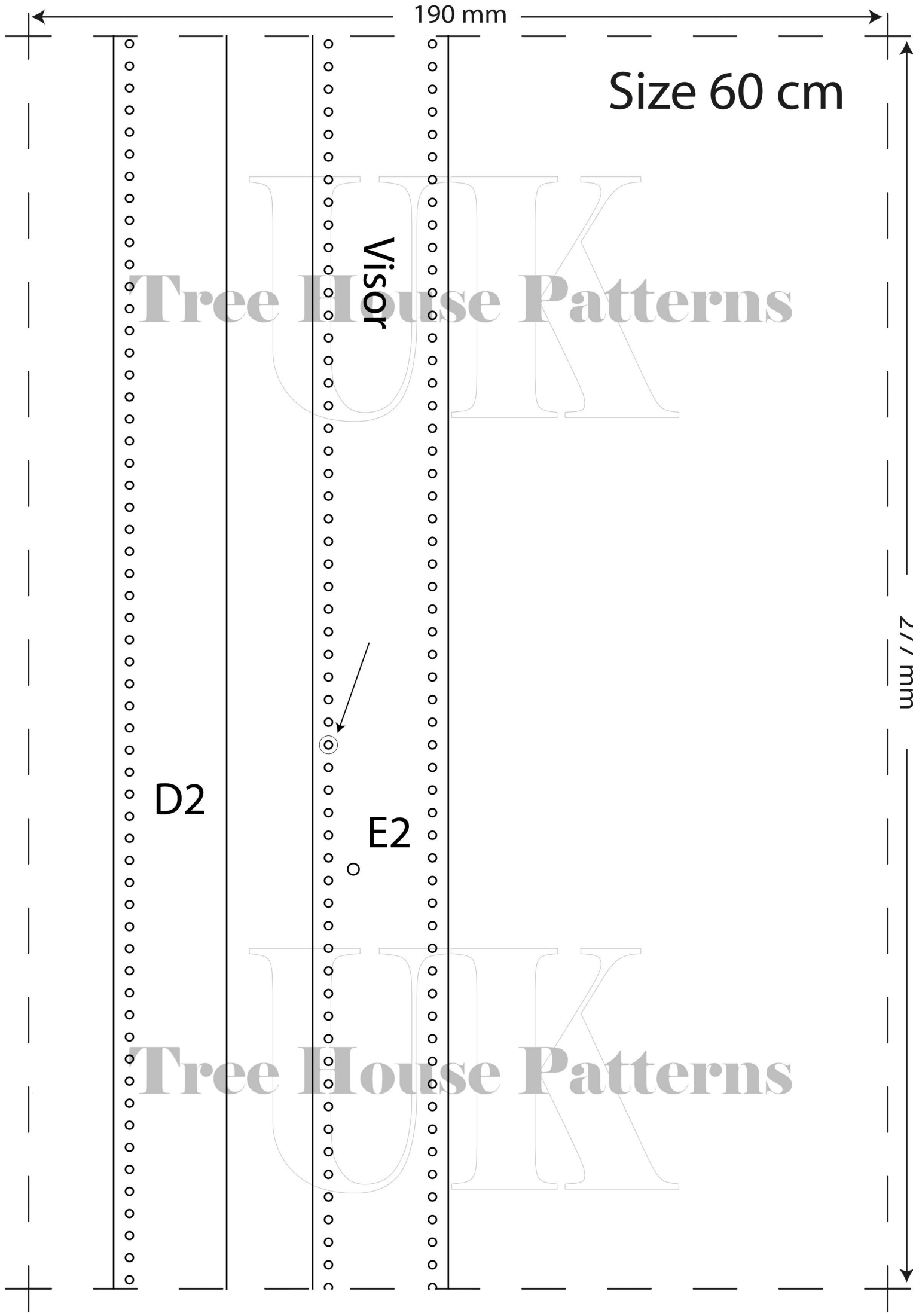

190 mm

Size 60 cm

D3

E3

Leather 1.8 - 2.0 mm

277 mm

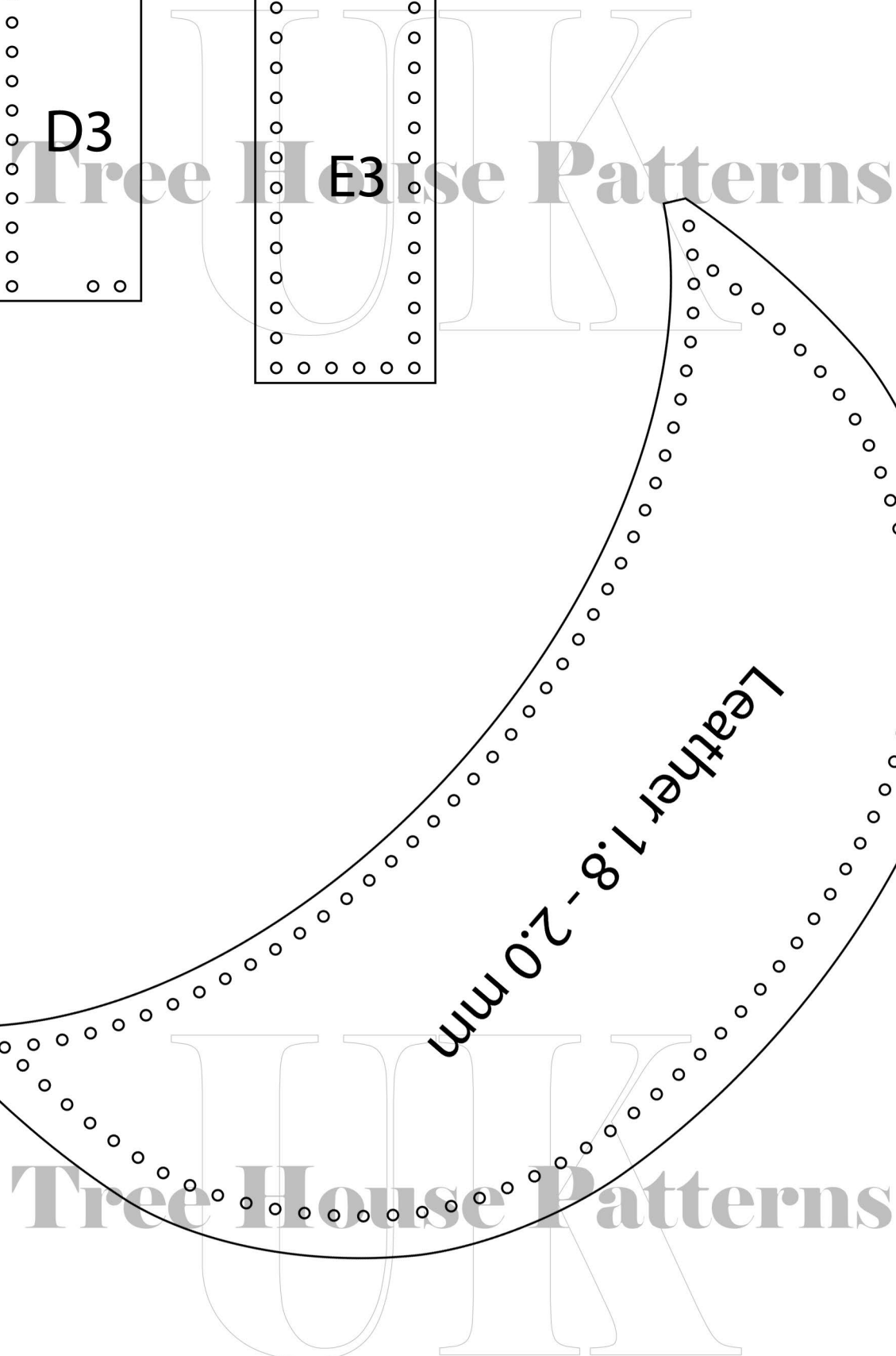

190 mm

Size 61 cm

# Tree House Patterns

The circumference of the top of the cap is larger than that of the gusset, and the holes for the threads are further apart.

Therefore, for this project, use soft leather for the top and gusset which will drape well. We used water buffalo leather with a thickness of 1.3 - 1.5 mm.

In this size of the cap, sewing is done in the normal way (red points on the pattern are for preview only)

277 mm

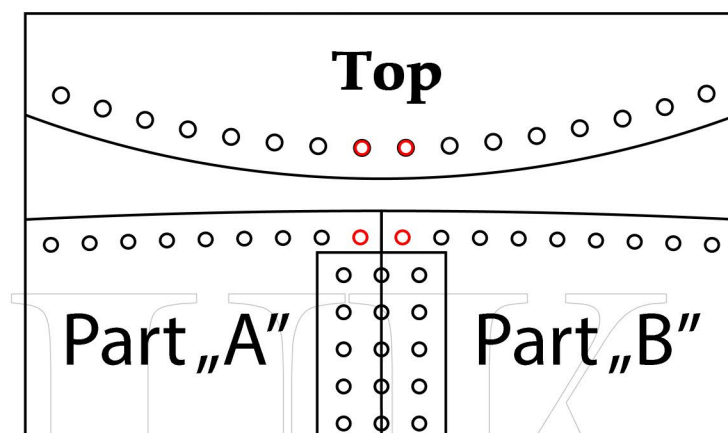

# Tree House Patterns

190 mm

Size 61 cm

Tree House Patterns

C1

Soft leather 1.3 - 1.5 mm

Tree House Patterns

277 mm

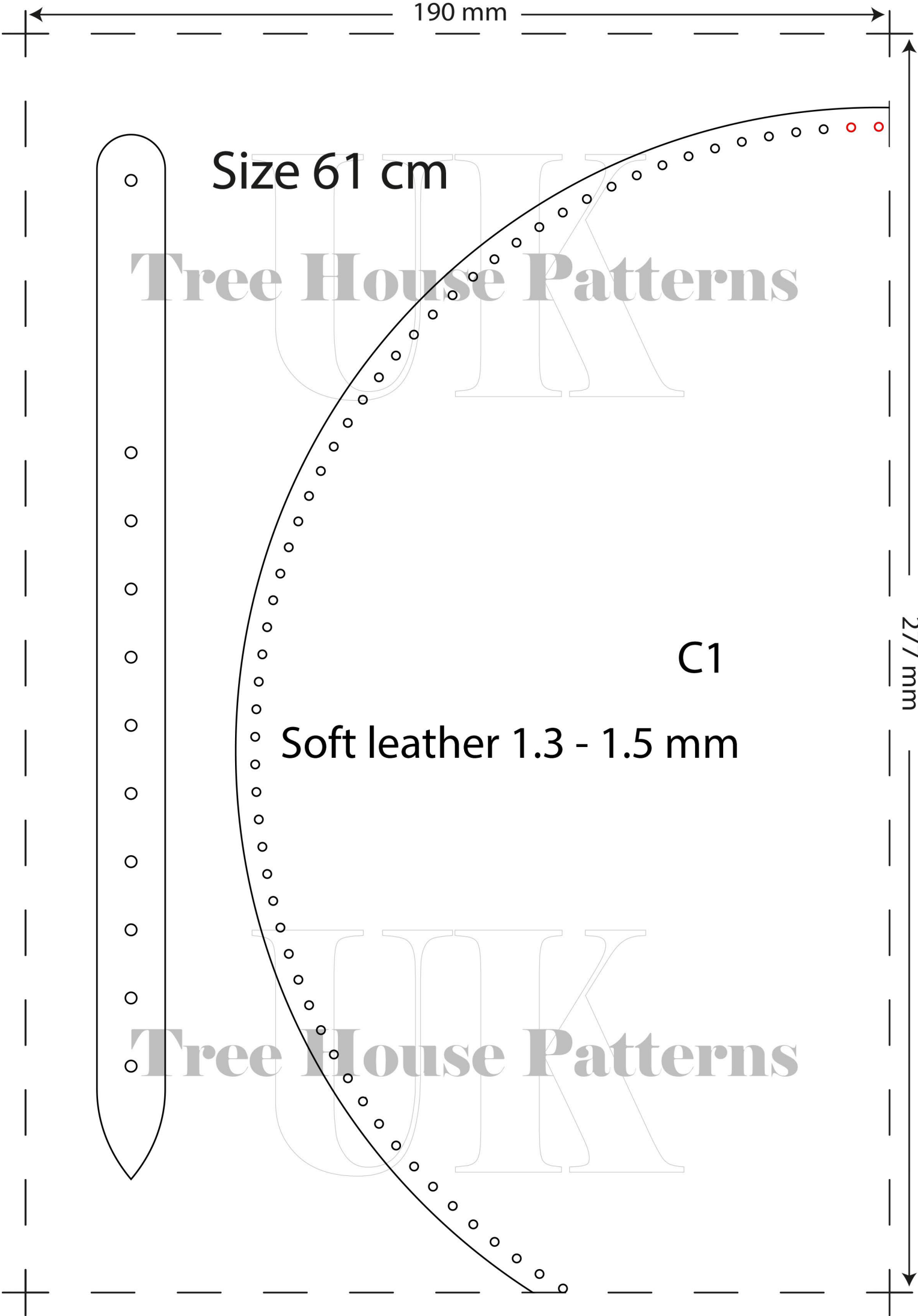

190 mm

Size 61 cm

Tree House Patterns

C2

Tree House Patterns

277 mm

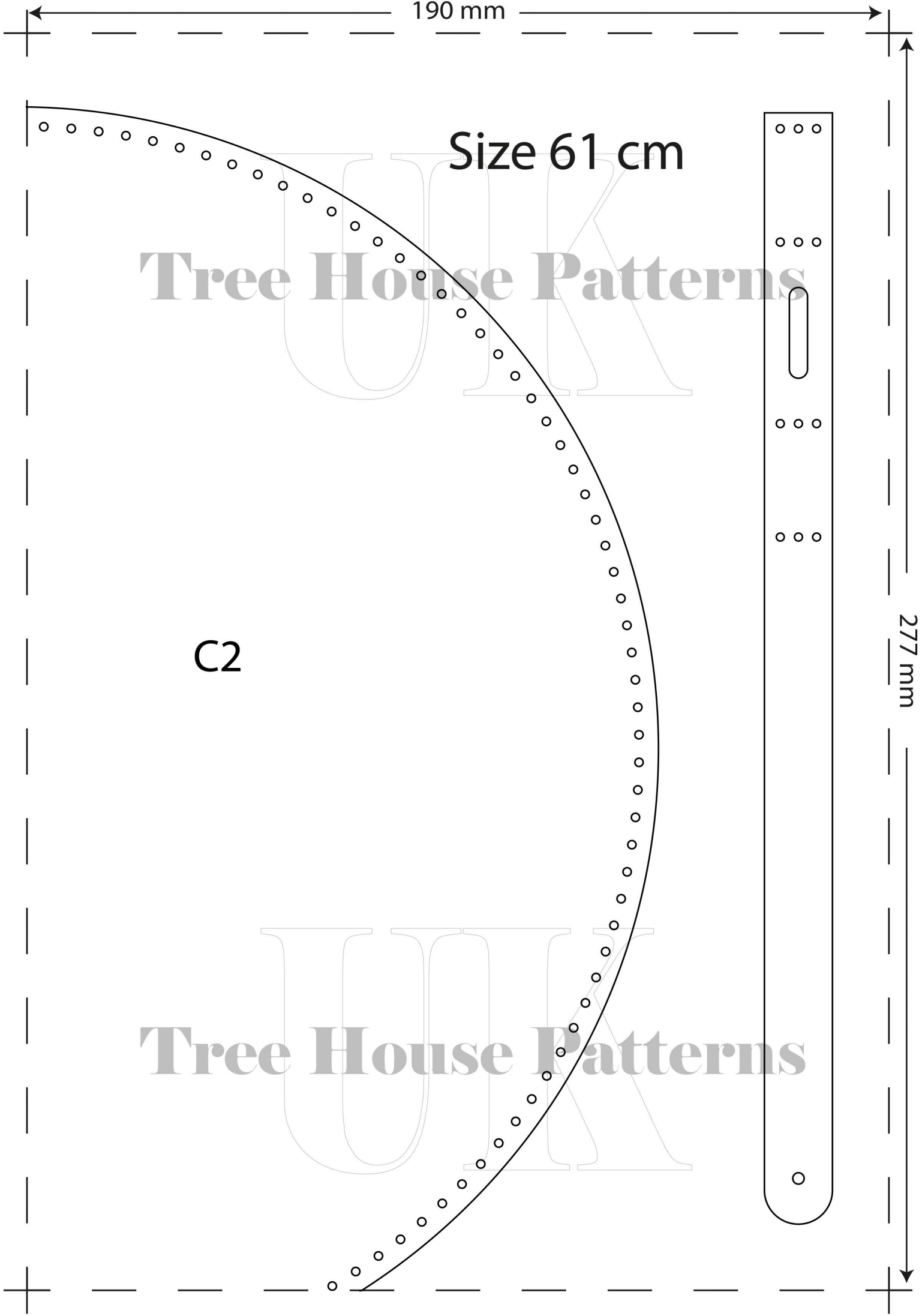

190 mm

Size 61 cm

Tree House Patterns

Soft leather 1.3 - 1.5 mm

A1

Part „A”

277 mm

B1

Tree House Patterns

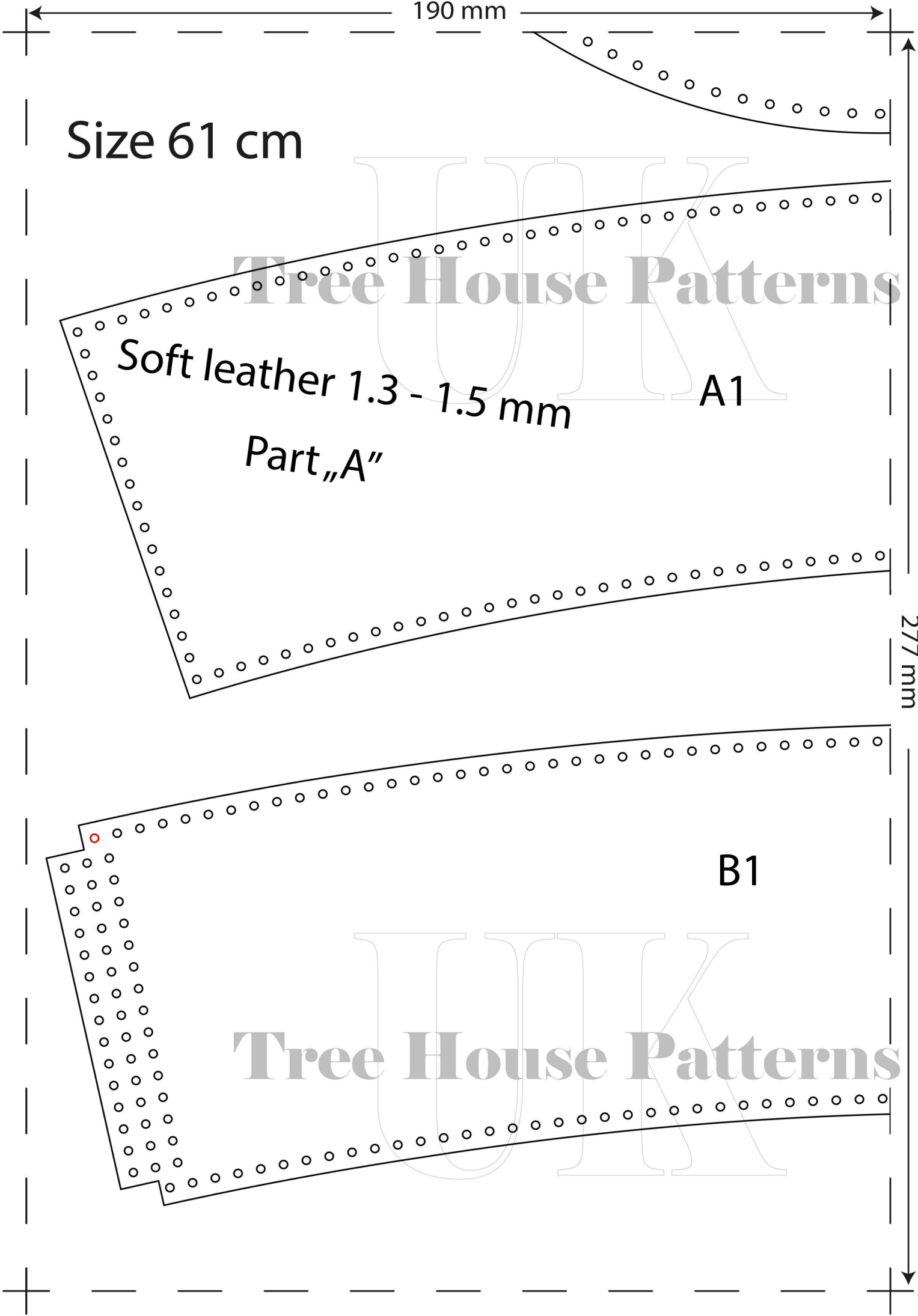

190 mm

Size 61 cm

A2

277 mm

B2

Soft leather 1.3 - 1.5 mm

ns

Tree House Patterns

ns

Tree House Patterns

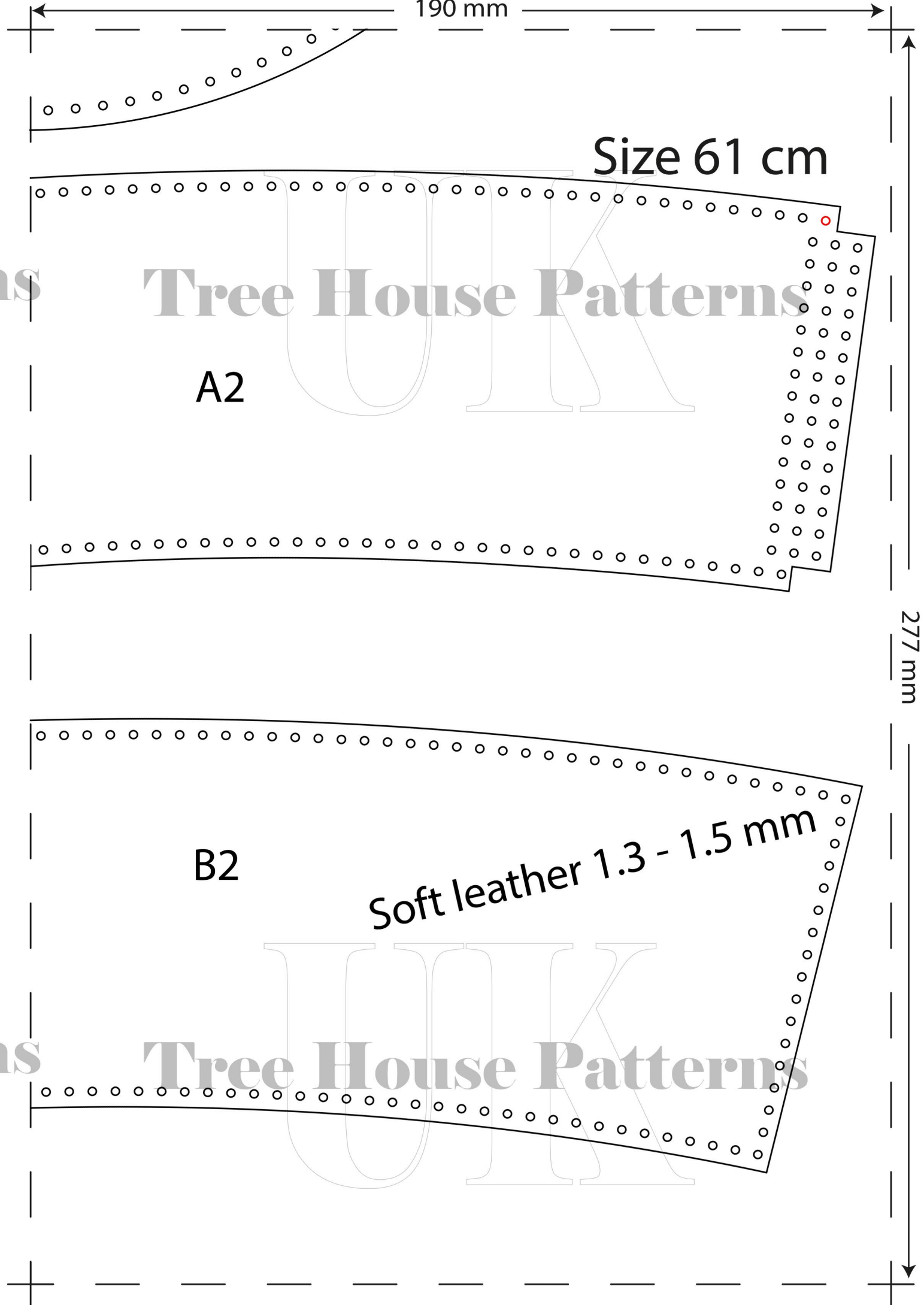

190 mm

277 mm

Size 61 cm

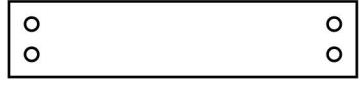
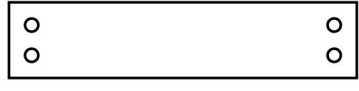
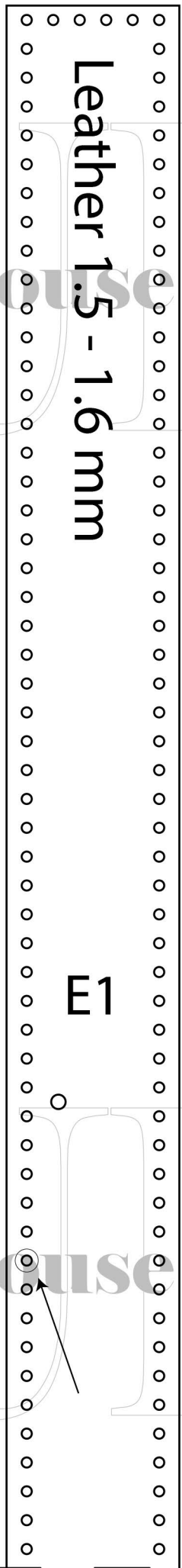
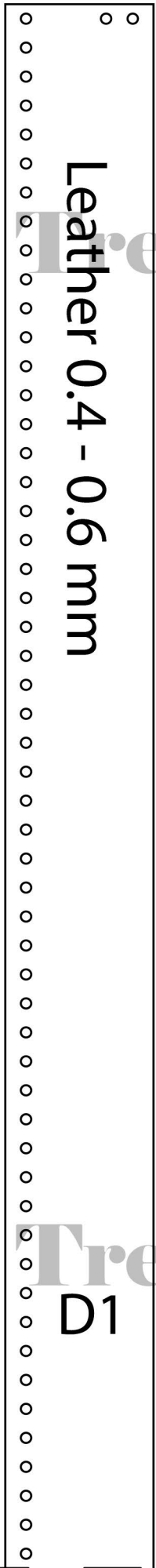

Free House Patterns

Free House Patterns



190 mm

Size 61 cm

Tree House Patterns

Visor

D2

E2

277 mm

Tree House Patterns

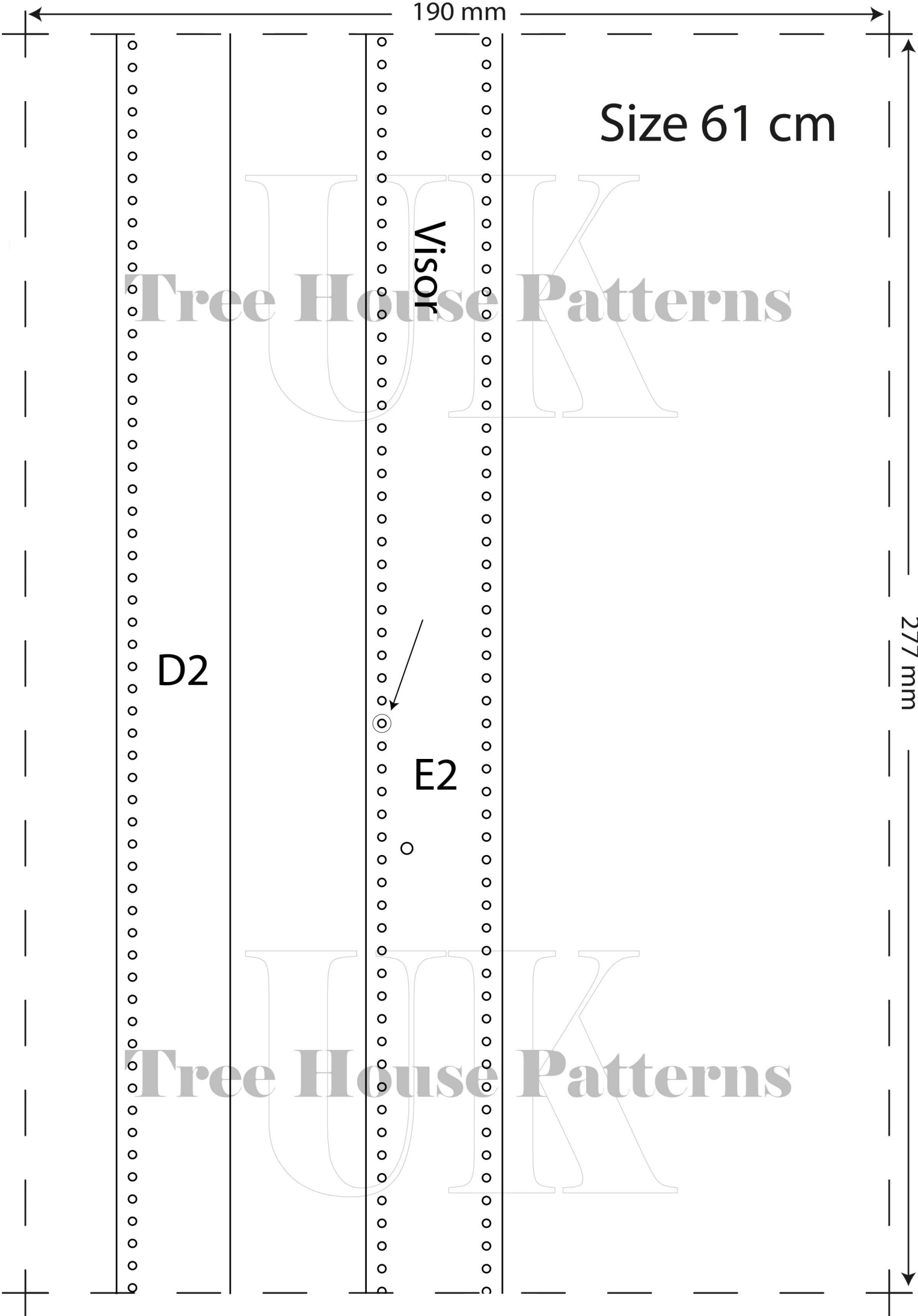

190 mm

D3

E3

Size 61 cm

Tree House Patterns

277 mm

Leather 1.8 - 2.0 mm

Tree House Patterns

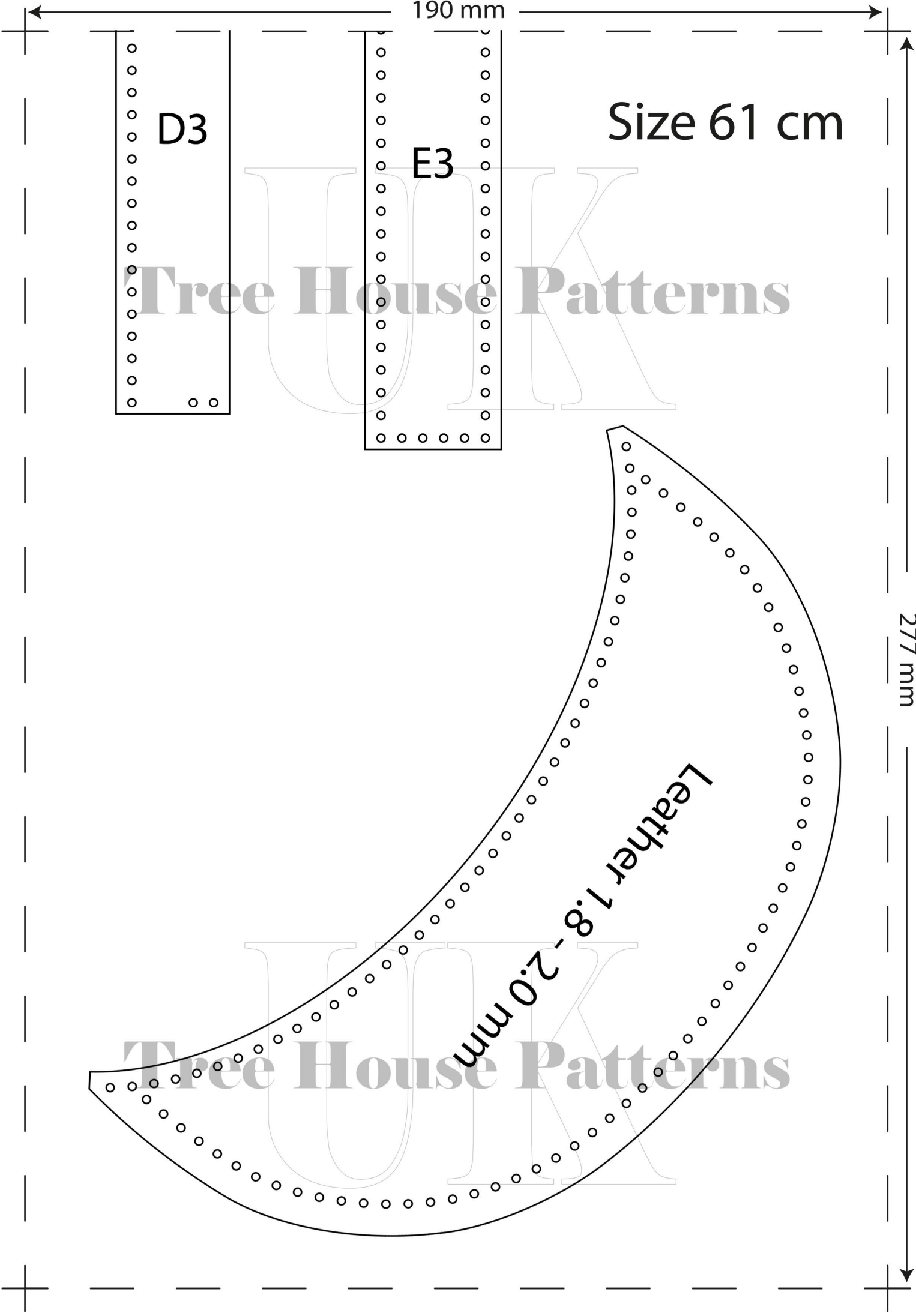

**COPYRIGHTS**  
**TreeHousePatternsUK**

**Dear customers,**  
**we would like to inform you**  
**that we allow the sale of physical products**  
**made by you on the basis of our designs in your stationary stores,**  
**online stores or fairs,**  
**as many as You wish.**

**However, we do not agree to the resale**  
**of our templates,**  
**any abuse of this will be reported.**

**We will be pleased if,**  
**by displaying photos of your products**  
**made on the basis of our template,**  
**You will add us as the creator of the project,**  
**or attach a link to the store where**  
**the template was purchased.**

**We are not making SVG files**  
**and please don't ask**  
**us to**  
**convert the PDF files we have**  
**created into an SVG file**

**Tree House Patterns**