

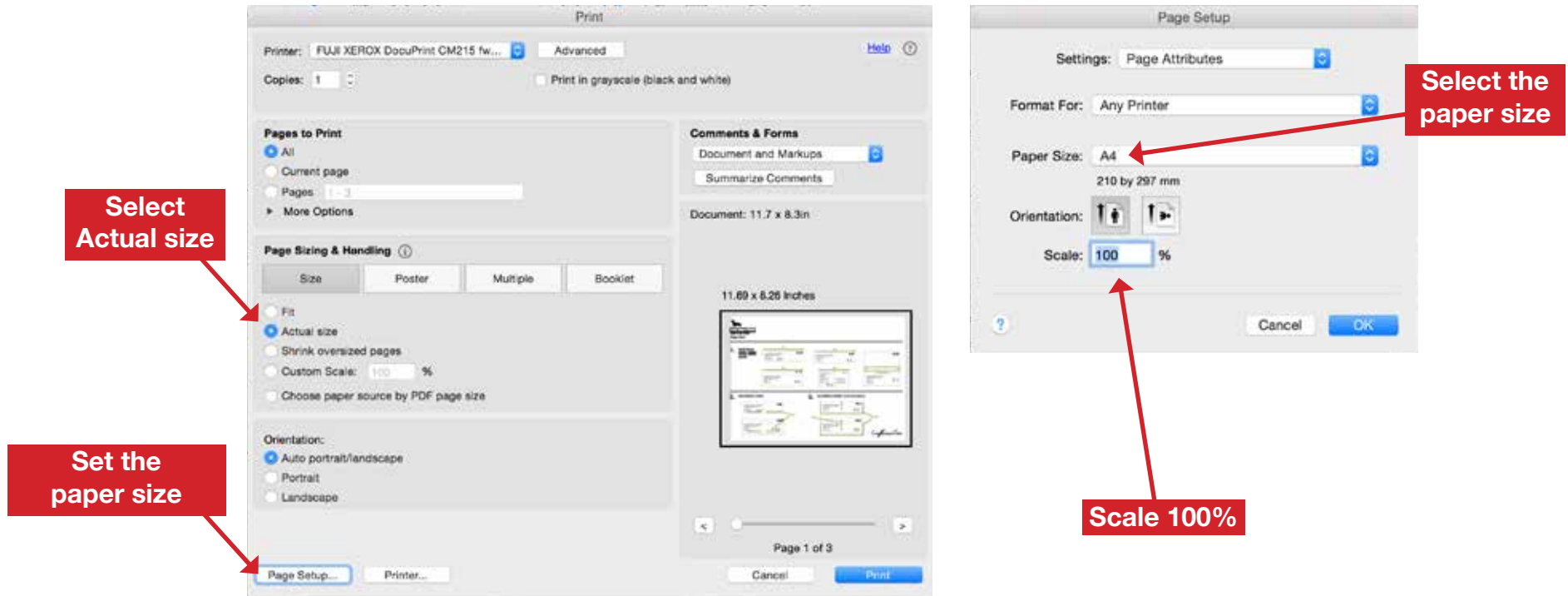

PRINTING INSTRUCTION

1. File > Print
2. Click on “Page Setup” button make sure your paper size is set to the paper size that you will print and Scale at 100%
3. In “Pages Sizing & Handling” click on “Size” button and select “Actual size”



IMPORTANT NOTE:

- **ADOBE ACROBAT READER (FREE SOFTWARE)** is recommended to open and print the patterns

link for free download

<https://get.adobe.com/reader>

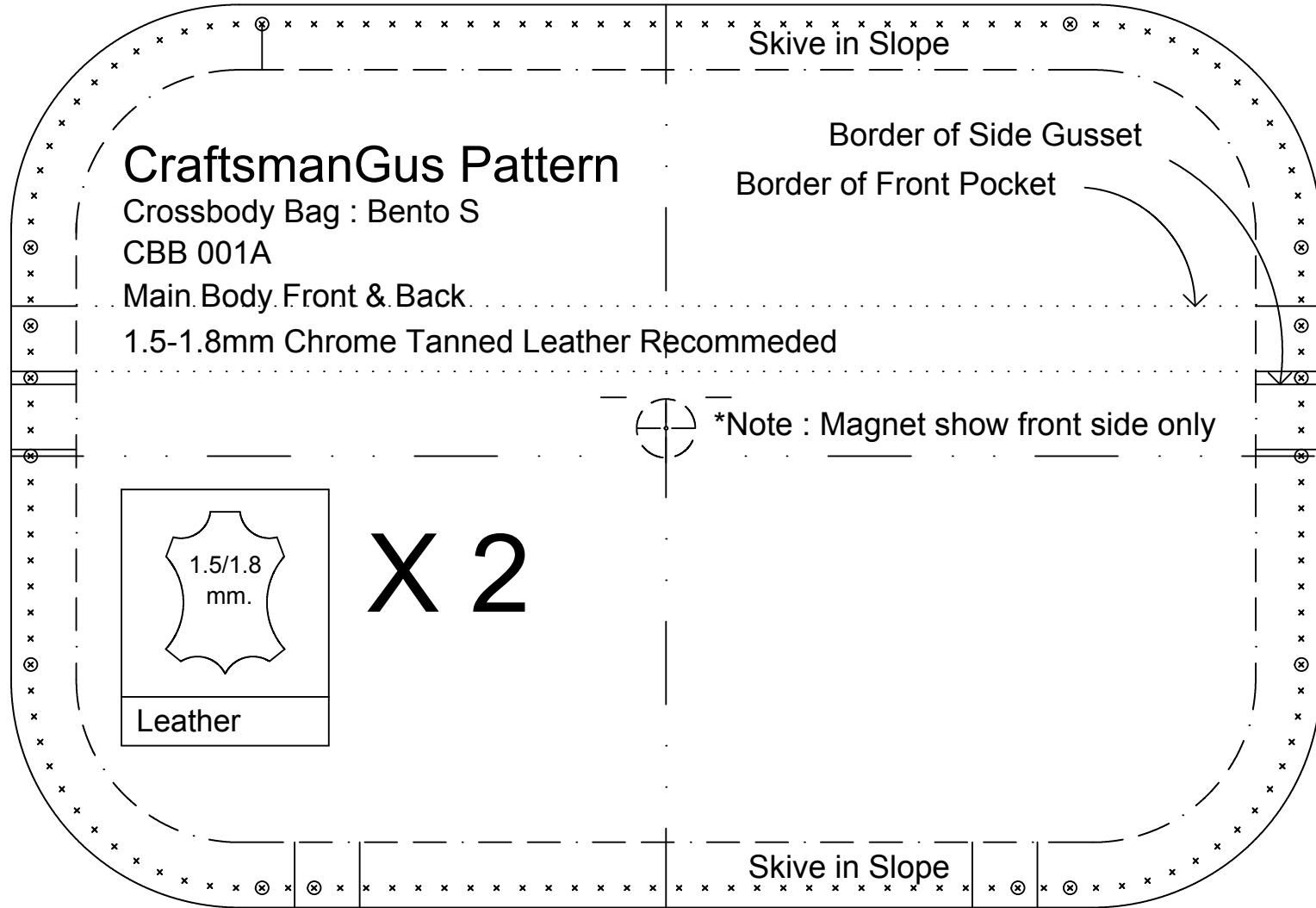

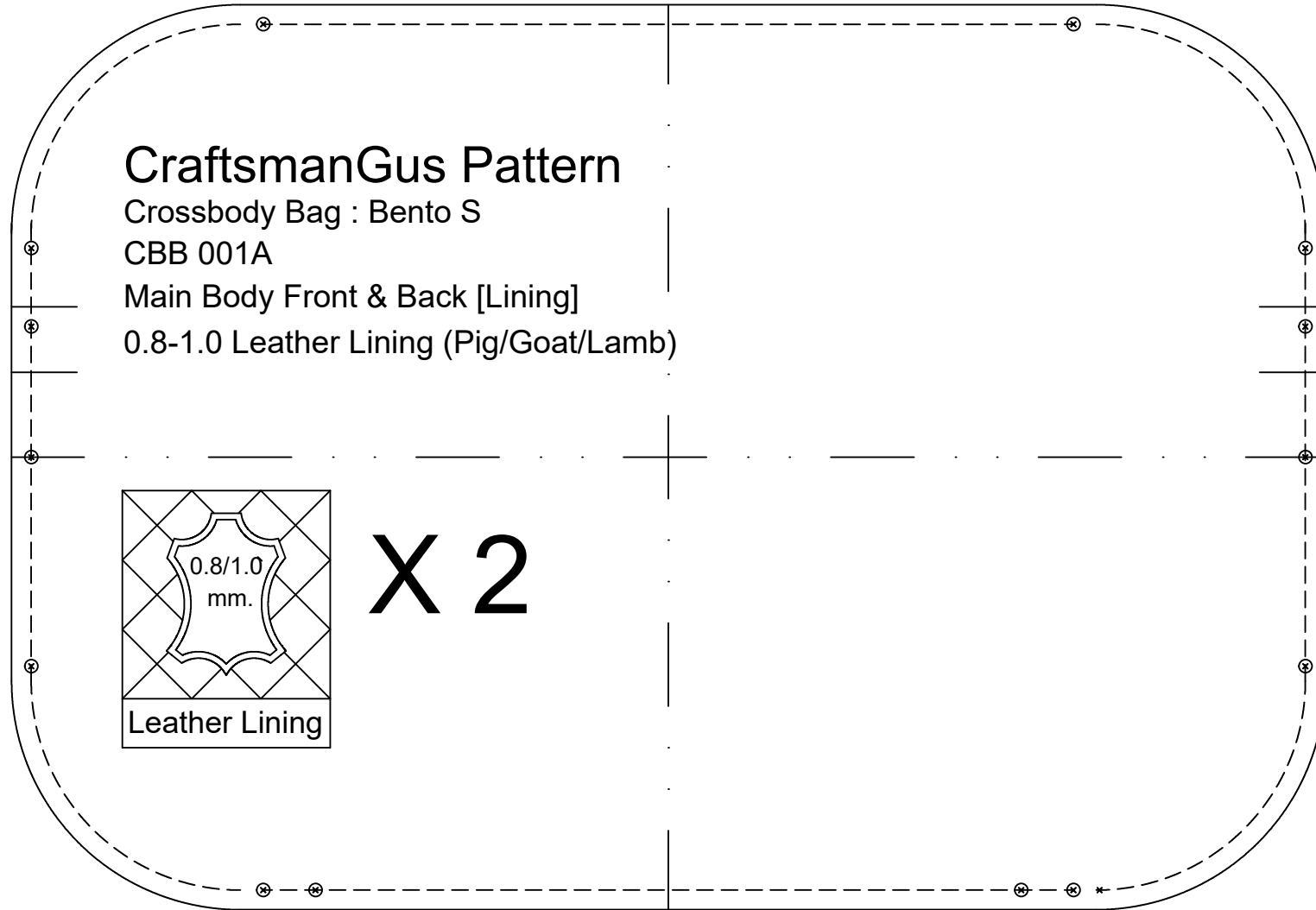



Cross Body Bag (Bento)

Page 3 of 8

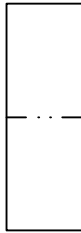

CraftsmanGus Pattern

Crossbody Bag : Bento S

CBB 001A

D-Ring Holder

X 2

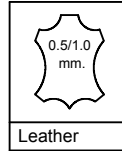

Leather

1.0mm Chrome Tanned Leather Recommended (For Edge Paint)

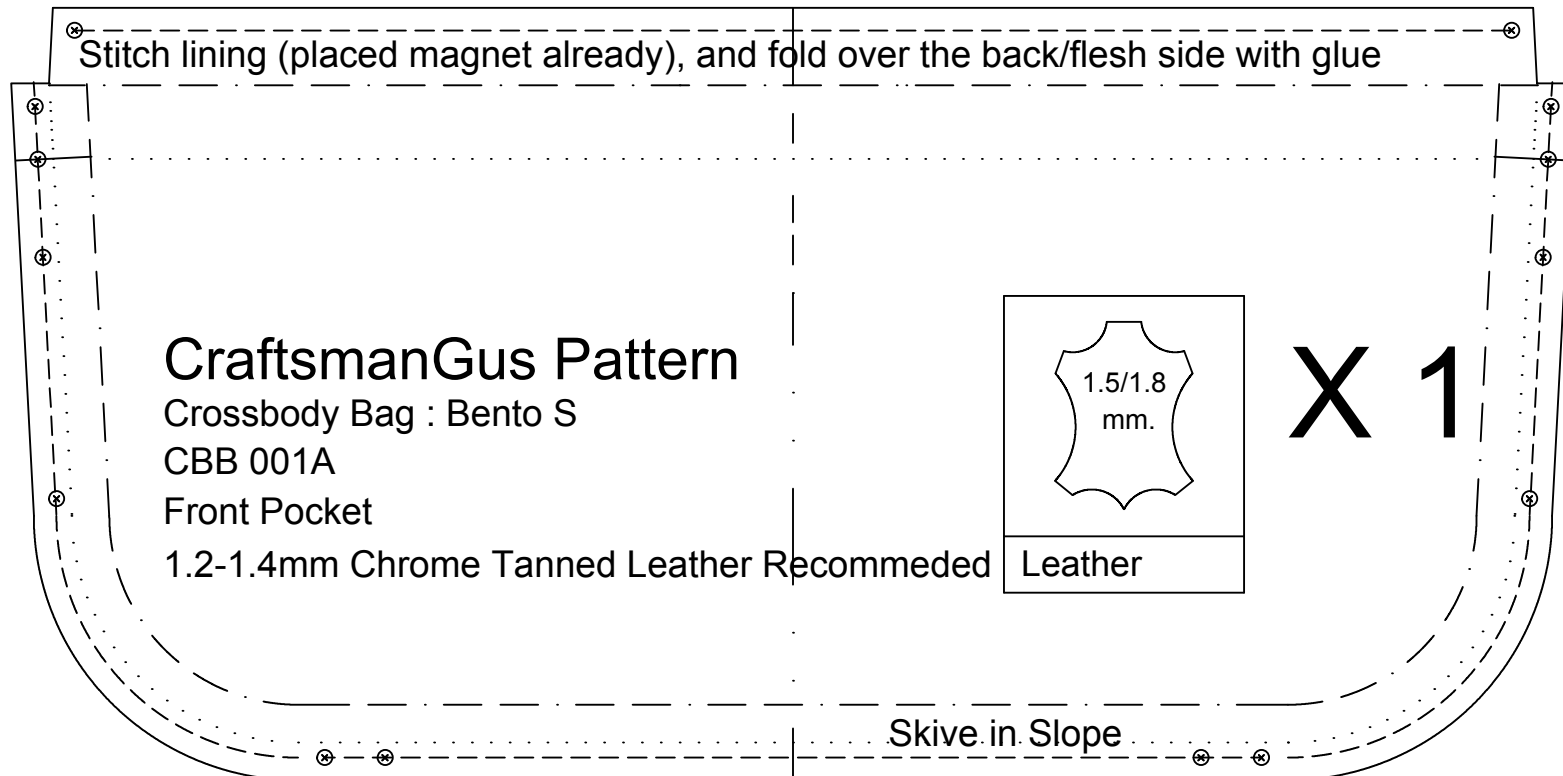



⊗-----⊗

⊕

*Note : Magnet show front side only

CraftsmanGus Pattern
Crossbody Bag : Bento S
CBB 001A
Front Pocket [Lining]
Canvas/Cotton/Denim Lining Fabric Recommeded

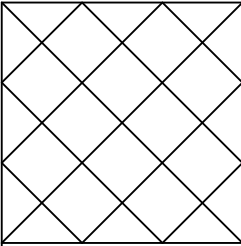

X 1

Fabric Lining

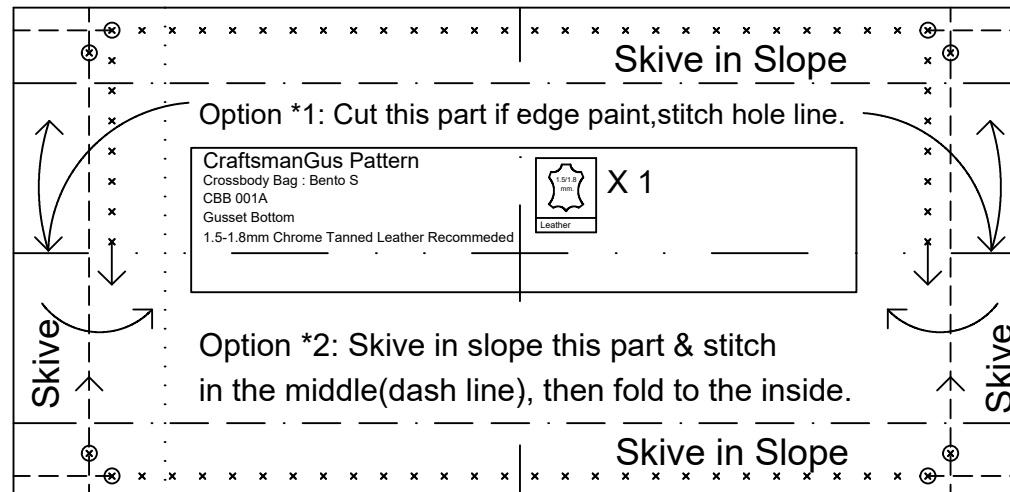
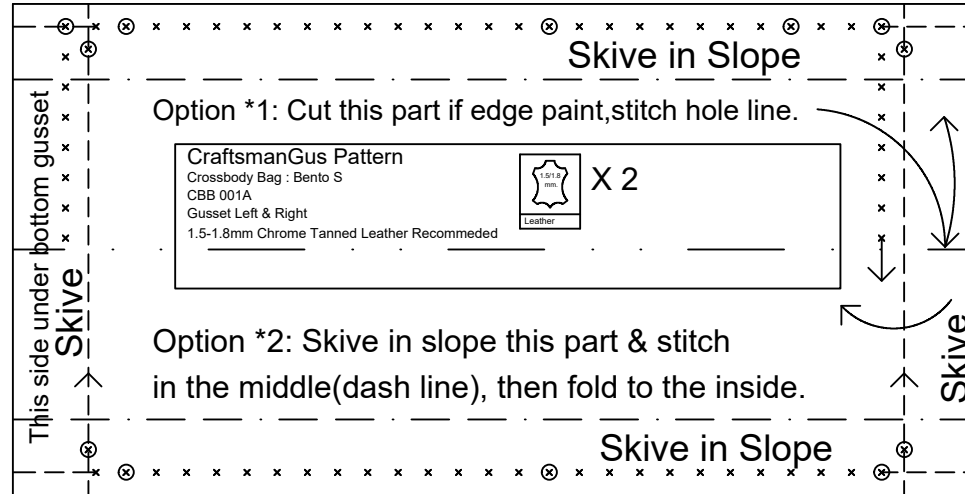



Cross Body Bag (Bento)

Page 6 of 8

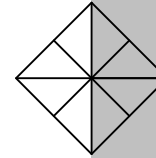

Tile to page 7

This side under side gusset

CraftsmanGus Pattern
 Crossbody Bag : Bento S
 CBB 001A
 Gusset Top (Zipper Part)
 1.5-1.8mm Chrome Tanned Leather Recommended

 X 2

Skive in S

This side under side gusset

CraftsmanGus Pattern
 Crossbody Bag : Bento S
 CBB 001A
 Gusset Top (Zipper Part) [Lining]
 0.8-1.0 Leather Lining (Pig/Goat/Lamb)

 X 2

Skive in S

CraftsmanGus Pattern
 Crossbody Bag : Bento S
 CBB 001A
 Gusset Bottom [Lining]
 0.8-1.0 Leather Lining (Pig/Goat/Lamb)

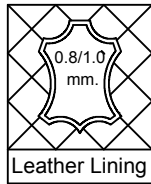
 X 1

*Note: If use "Stitch and fold over method need to trim a bit (no need to stitch through lining layer) on these side.

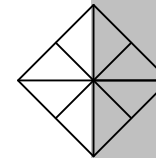



Cross Body Bag (Bento)

Page 7 of 8

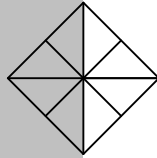

Tile to page 6

Gus Pattern
 Bento S
 Leather
 X 2
 Skive in Slope
 This side under side gusset

Gus Pattern
 Bento S
 Leather Lining
 X 2
 Skive in Slope
 This side under side gusset

s Pattern
 o S
 Leather Lining
 0.8/1.0 mm.
 X 1
 This side under side gusset
 stitch and fold over method need to trim a bit (no need to stitch through lining layer) on these side.

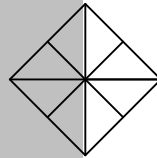



Cross Body Bag (Bento)

Page 8 of 8

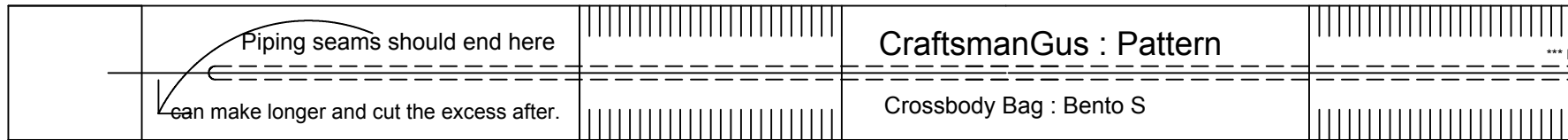

Connect

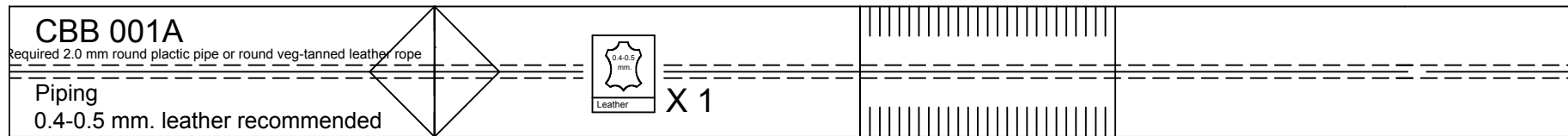

Connect

